

# Modular Pneumatic Solutions

## Air Distribution

**Luftverteilung** • エアーデイス トリビューション  
हवा वितरण • **Distribuição de Ar** • 气流分配



# ROSS Lite Modular Solutions

## An economical solution to manifold systems

The ROSS Lite System offers most of the advantages as standard Modular Solutions but at a reduced cost.

### Features:

- Standardized pre-engineered systems.
- Reduced potential for air leaks.
- Reduced installation and engineering costs.
- Easy replacement of components.
- Reduced space requirements.

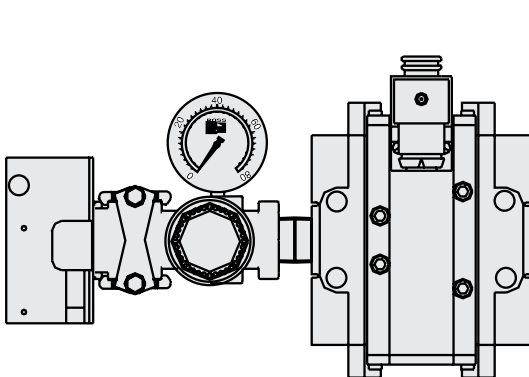
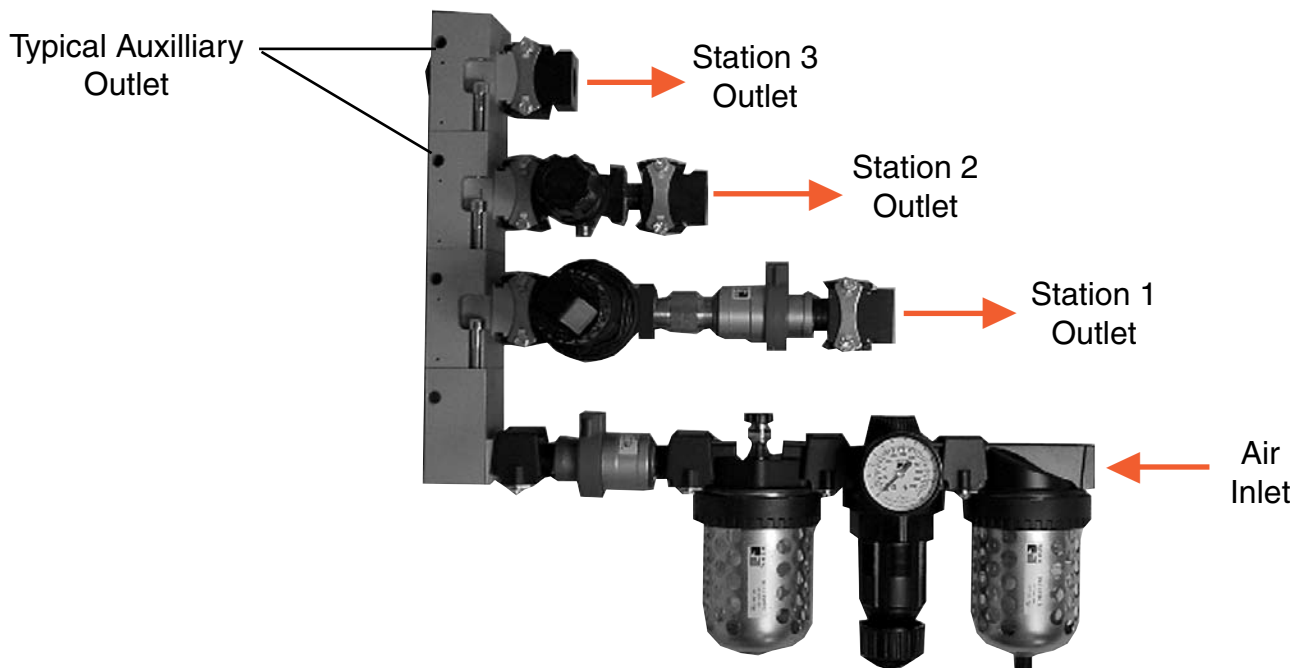

Shown with optional ISO valve

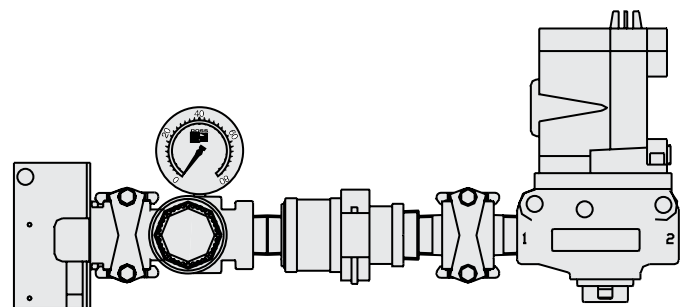

Shown with optional Series 27 valve

Circuits can be furnished with valves, manifolds, and other options.

# Modular Air Distribution

## Economy Size 8

### Main Air Panel Applications Basic Branch Circuits

**Inlet Port 3/4**  
**Outlet Port 1/2**

- Supply headers equipped with auxiliary outlet 3/4" NPT or BSPP port.
- Gauges shipped loose for field installation.
- Modules can be stacked to fit application - assembly hardware included.
- For circuits with valves and other options, consult ROSS.

#### MAS-H-N8-A (NPT)

#### MAS-H-B8-A (BSPP)

Supply header outlet.

Dimensions inches (mm)			Weight
Height	Width	Length	lb (kg)
3.2 (81.2)	2.8 (71)	3.8 (96.5)	3.0 (1.36)

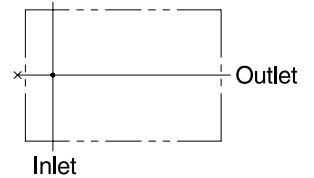
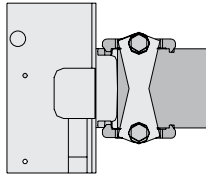

#### MAS-HR-N8-A (NPT)

#### MAS-HR-B8-A (BSPP)

Supply header with regulator.

Dimensions inches (mm)			Weight
Height	Width	Length	lb (kg)
4.1 (104)	4.7 (119)	6.7 (170)	4.2 (1.90)

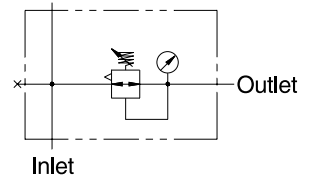
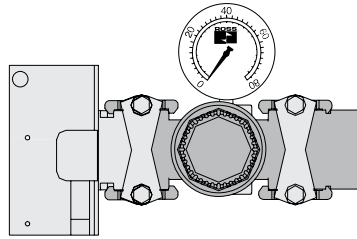

#### MAS-HRC-N8-A (NPT)

#### MAS-HRC-B8-A (BSPP)

Supply header with regulator and check.

Dimensions inches (mm)			Weight
Height	Width	Length	lb (kg)
4.1 (104)	4.7 (119)	9.3 (236)	4.67 (2.12)

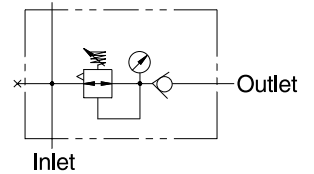
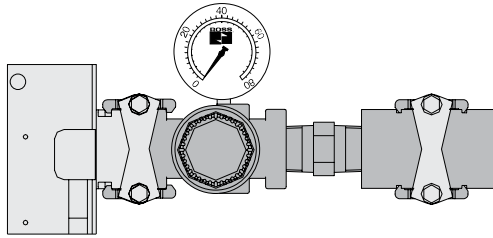

#### MAS-HRX-N8-A (NPT)

#### MAS-HRX-B8-A (BSPP)

Supply header with regulator and shut-off.

Dimensions inches (mm)			Weight
Height	Width	Length	lb (kg)
4.1 (104)	4.7 (119)	11.5 (292)	5.0 (2.27)

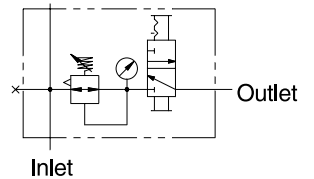
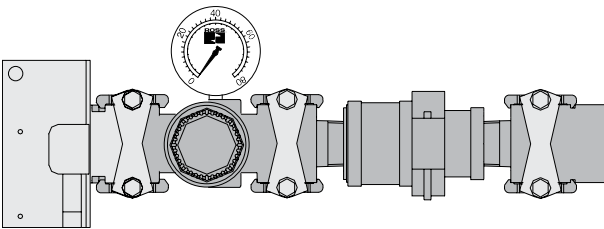

#### MAS-HRCX-N8-A (NPT)

#### MAS-HRCX-B8-A (BSPP)

Supply header with regulator, check, and shut-off.

Dimensions inches (mm)			Weight
Height	Width	Length	lb (kg)
4.1 (104)	4.7 (119)	11.7 (297)	4.75 (2.15)

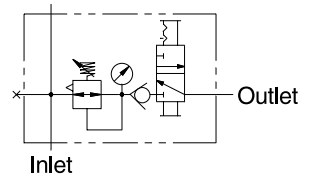
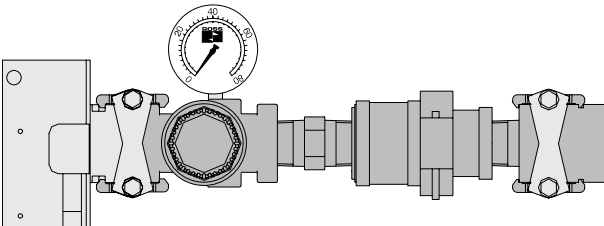

**STANDARD SPECIFICATIONS:** For valves on this page.

**Ambient Temperature:** 40° to 120°F (4° to 50°C).

**Media Temperature:** 40° to 175°F (4° to 80°C).

**Flow Media:** Filtered air; 5 micron recommended.

**Inlet Pressure:** 0 to 150 psig (0 to 10 bar).

# Modular Air Distribution

## Economy Size 12

### Main Air Panel Applications Basic Branch Circuits

**Inlet Port 3/4"**  
**Outlet Port 3/4"**

- Supply headers equipped with auxiliary outlet 3/4" NPT or BSPP port.
- Gauges shipped loose for field installation.
- Modules can be stacked to fit application - assembly hardware included.
- For circuits with valves and other options, consult ROSS.

#### MAS-H-N12-A (NPT)

#### MAS-H-B12-A (BSPP)

Supply header outlet.

Dimensions inches (mm)			Weight
Height	Width	Length	lb (kg)
3.2 (81.2)	2.8 (71)	3.8 (96.5)	3.0 (1.36)

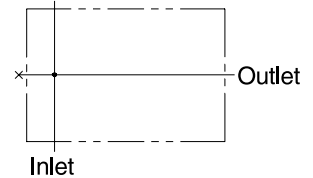
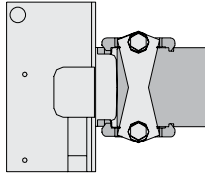

#### MAS-HR-N12-A (NPT)

#### MAS-HR-B12-A (BSPP)

Supply header with regulator.

Dimensions inches (mm)			Weight
Height	Width	Length	lb (kg)
4.6 (117)	7.2 (103)	7.5 (191)	5.4 (2.45)

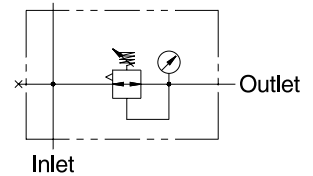
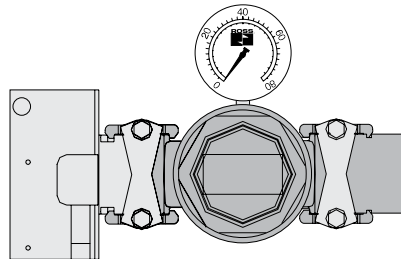

#### MAS-HRC-N12-A (NPT)

#### MAS-HRC-B12-A (BSPP)

Supply header with regulator and check.

Dimensions inches (mm)			Weight
Height	Width	Length	lb (kg)
4.6 (117)	7.2 (183)	10.4 (264)	5.87 (2.66)

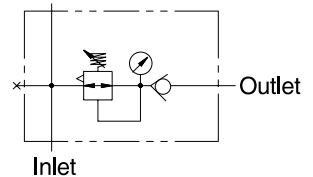
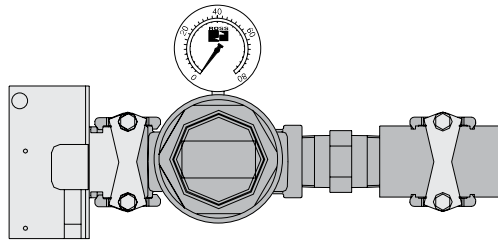

#### MAS-HRX-N12-A (NPT)

#### MAS-HRX-B12-A (BSPP)

Supply header with regulator and shut-off.

Dimensions inches (mm)			Weight
Height	Width	Length	lb (kg)
4.6 (117)	7.2 (183)	12.1 (307)	5.97 (2.71)

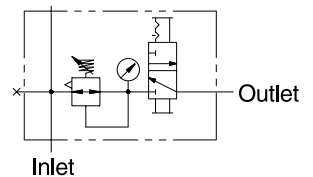
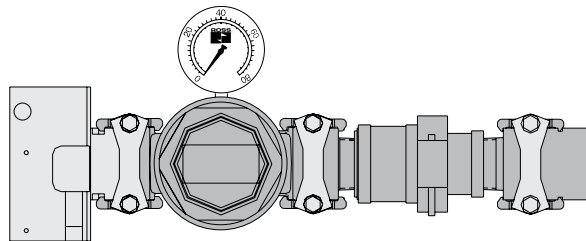

#### MAS-HRCX-N12-A (NPT)

#### MAS-HRCX-B12-A (BSPP)

Supply header with regulator, check, and shut-off.

Dimensions inches (mm)			Weight
Height	Width	Length	lb (kg)
4.6 (117)	7.2 (183)	12.7 (323)	6.08 (2.76)

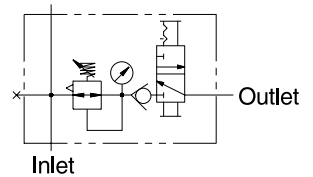
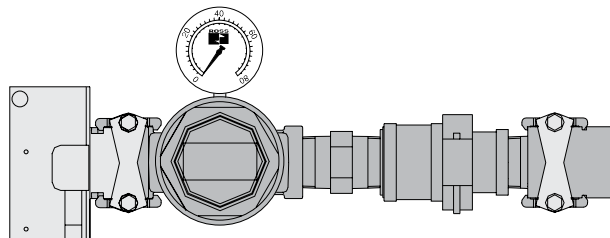

**STANDARD SPECIFICATIONS:** For valves on this page.

**Ambient Temperature:** 40° to 120°F (4° to 50°C).

**Media Temperature:** 40° to 175°F (4° to 80°C).

**Flow Media:** Filtered air; 5 micron recommended.

**Inlet Pressure:** 0 to 150 psig (0 to 10 bar).

# Modular Air Distribution

## Size 12

Inlet Air Prep Units  
Inlet Port 3/4

- Prepares inlet air supply for entire stack.
- Attaches to the bottom of the branch circuit stack.
- Gauges shipped loose for field installation.
- Assembly hardware included.

### MAS-FH-N12-A (NPT)

### MAS-FH-B12-A (BSPP)

Inlet with filter and supply header.

Dimensions inches (mm)			Weight
Height	Width	Length	lb (kg)
8.5 (216)	3.6 (91)	8.0 (203)	4.0 (1.9)

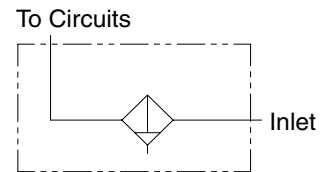
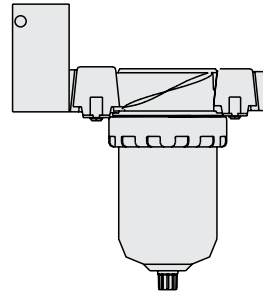

### MAS-FLH-N12-A (NPT)

### MAS-FLH-B12-A (BSP)

Inlet with filter, lubricator, and supply header.

Dimensions inches (mm)			Weight
Height	Width	Length	lb (kg)
8.5 (216)	3.6 (91)	12.0 (305)	7.0 (3.2)

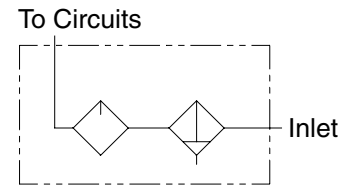
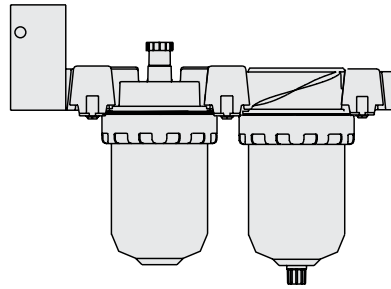

### MAS-FRH-N12-A (NPT)

### MAS-FRH-B12-A (BSP)

Inlet with filter, regulator, and supply header.

Dimensions inches (mm)			Weight
Height	Width	Length	lb (kg)
8.5 (216)	3.6 (91)	11.5 (292)	7.0 (3.2)

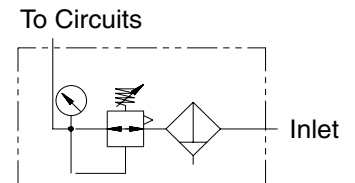
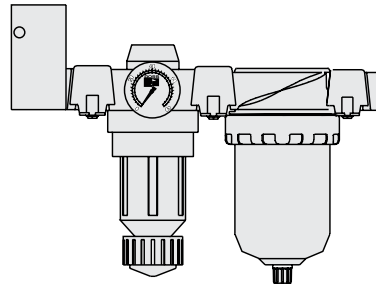

### MAS-FRLH-N12-A (NPT)

### MAS-FRLH-B12-A (BSP)

Inlet with filter, regulator lubricator, and supply header.

Dimensions inches (mm)			Weight
Height	Width	Length	lb (kg)
8.5 (216)	3.6 (91)	15.6 (356)	10.0 (4.6)

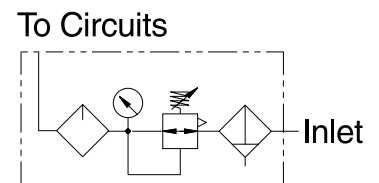
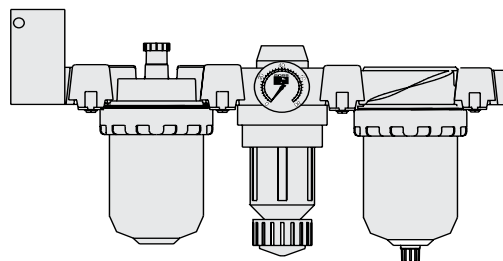

**STANDARD SPECIFICATIONS:** For valves on this page.  
**Ambient Temperature:** 40° to 120°F (4° to 50°C).  
**Media Temperature:** 40° to 175°F (4° to 80°C).

**Fluid Media:** Compressed air.  
**Inlet Pressure:** 200 psig max. (14 bar).

# Modular Air Distribution

## Size 12

### Inlet Air Prep Units

### Inlet Port 3/4

- Prepares inlet air supply for entire stack.
- Attaches to the bottom of the branch circuit stack.
- Gauges shipped loose for field installation.
- Assembly hardware included.

#### MAS-FXH-N12-A (NPT)

#### MAS-FXH-B12-A (BSPP)

Inlet with filter, shut-off, and supply header.

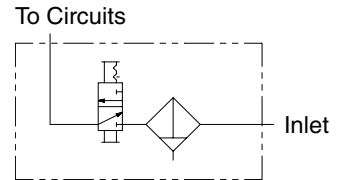
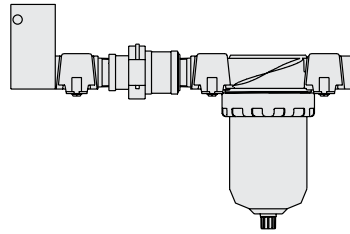

Dimensions inches (mm)			Weight
Height	Width	Length	lb (kg)
8.5 (216)	3.6 (91)	13.0 (330)	5.0 (2.3)

#### MAS-FLXH-N12-A (NPT)

#### MAS-FLXH-B12-A (BSPP)

Inlet with filter, lubricator shut-off, and supply header.

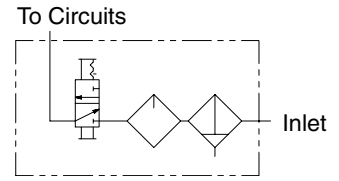
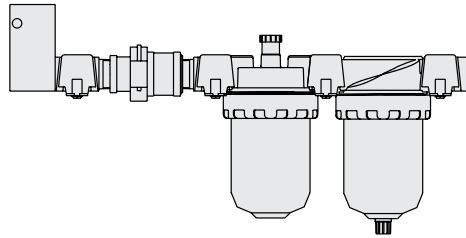

Dimensions inches (mm)			Weight
Height	Width	Length	lb (kg)
8.5 (216)	3.6 (91)	17.0 (432)	8.0 (3.6)

#### MAS-FRXH-N12-A (NPT)

#### MAS-FRXH-B12-A (BSPP)

Inlet with filter, regulator, shut-off, and supply header.

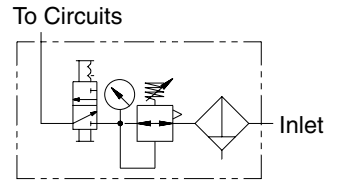
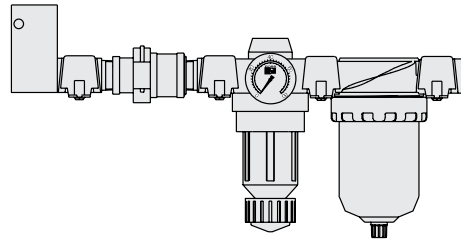

Dimensions inches (mm)			Weight
Height	Width	Length	lb (kg)
8.5 (216)	3.6 (91)	16.72 (432)	8.0 (3.6)

#### MAS-FRLXH-N12-A (NPT)

#### MAS-FRLXH-B12-A (BSPP)

Inlet with filter, regulator lubricator, shut-off, and supply header.

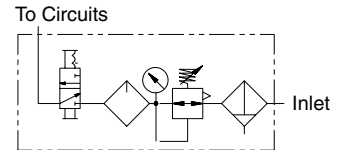
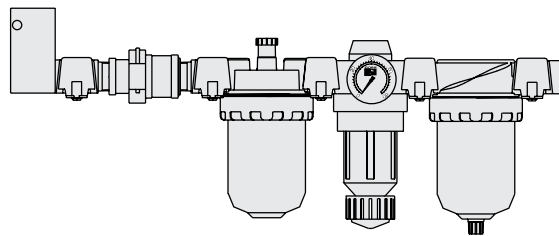

Dimensions inches (mm)			Weight
Height	Width	Length	lb (kg)
8.5 (216)	3.6 (91)	20.75 (527)	11.0 (5.0)

**STANDARD SPECIFICATIONS:** For valves on this page.  
**Ambient Temperature:** 40° to 120°F (4° to 50°C).  
**Media Temperature:** 40° to 175°F (4° to 80°C).

**Fluid Media:** Compressed air.  
**Inlet Pressure:** 200 psig max. (14 bar).

# Cautions

## PRE-INSTALLATION or SERVICE

1. Before servicing a valve or other pneumatic component, be sure that all sources of energy are turned off, the entire pneumatic system is shut off and exhausted, and all power sources are locked-out (ref: OSHA 1910.147, EN 1037).
2. All ROSS products, including service kits and parts, should be installed and/or serviced only by persons having training and experience with pneumatic equipment. Because any installation can be tampered with or need servicing after installation, persons responsible for the safety of others or the care of equipment must check every installation on a regular basis and perform all necessary maintenance.
3. All applicable instructions should be read and complied with before using any fluid power system in order to prevent harm to persons or equipment. In addition, overhauled or serviced valves must be functionally tested prior to installation and use.
4. Each ROSS product should be used within its specification limits. In addition, use only ROSS parts to repair ROSS products. Failure to follow these directions can adversely affect the performance of the product or result in the potential for human injury.

## FILTRATION and LUBRICATION

5. Dirt, scale, moisture, etc. are present in virtually every air system. Although some valves are more tolerant of these contaminants than others, best performance will be realized if a filter is installed to clean the air supply, thus preventing contaminants from interfering with the proper performance of the equipment. ROSS recommends a filter with a 5-micron rating for normal applications.
6. All standard ROSS filters and lubricators with polycarbonate plastic bowls are designed for compressed air applications only. Do *not* fail to use the metal bowl guard, where provided, to minimize danger from high pressure fragmentation in the event of bowl failure. Do not expose these products to certain fluids, such as alcohol or liquefied petroleum gas, as they can cause bowls to rupture, creating a combustible condition, hazardous leakage, and the potential for human injury. Immediately replace a crazed, cracked, or deteriorated bowl. When bowl gets dirty, replace it or wipe it with a clean dry cloth.

7. Only use lubricants which are compatible with materials used in the valves and other components in the system. Normally, compatible lubricants are petroleum base oils with oxidation inhibitors, an aniline point between 180°F (82°C) and 220°F (104°C), and an ISO 32, or lighter, viscosity. Avoid oils with phosphate type additives which can harm polyurethane components, potentially leading to valve failure and/or human injury. If you have questions regarding whether a lubricant used on your system is compatible with ROSS products, please contact ROSS.

## AVOID INTAKE/EXHAUST RESTRICTION

8. Do not restrict the air flow in the supply line. To do so could reduce the pressure of the supply air below the minimum requirements for the valve and thereby cause erratic action.
9. Do not restrict a valve's exhaust port as this can adversely affect its operation. Exhaust silencers must be resistant to clogging and have flow capacities at least as great as the exhaust capacities of the valves. Contamination of the silencer can result in reduced flow and increased back pressure.

*ROSS expressly disclaims all warranties and responsibility for any unsatisfactory performance or injuries caused by the use of the wrong type, wrong size, or inadequately maintained silencer installed with a ROSS product.*

## POWER PRESSES

10. Mechanical power presses and other potentially hazardous machinery using a pneumatically controlled clutch and brake mechanism must use a press control double valve with a monitoring device. A double valve without a self-contained monitoring device should be used only in conjunction with a control system which assures monitoring of the valve. All double valve installations involving hazardous applications should incorporate a monitoring system which inhibits further operation of the valve and machine in the event of a failure within the valve mechanism.

## ENERGY ISOLATION/EMERGENCY STOP

11. Per specifications and regulations, ROSS **L-O-X**® and manual **L-O-X**® with **EEZ-ON**® operation products are defined as energy isolation devices, NOT AS EMERGENCY STOP DEVICES.

# Warranty

Products manufactured by ROSS are warranted to be free of defects in material and workmanship for a period of one year from the date of purchase. ROSS' obligation under this warranty is limited to repair or replacement of the product or refund of the purchase price paid solely at the discretion of ROSS and provided such product is returned to ROSS freight prepaid and upon examination by ROSS such product is found to be defective. This warranty shall be void in the event that product has been subject to misuse, misapplication, improper maintenance, modification or tampering. THE WARRANTY EXPRESSED ABOVE IS IN LIEU OF AND EXCLUSIVE OF ALL OTHER WARRANTIES AND ROSS EXPRESSLY DISCLAIMS ALL OTHER WARRANTIES EITHER EXPRESSED OR IMPLIED WITH RESPECT TO MERCHANTABILITY OR FITNESS FOR A PARTICULAR PURPOSE. ROSS MAKES NO WARRANTY WITH RESPECT TO ITS PRODUCTS MEETING THE PROVISIONS OF ANY GOVERNMENTAL OCCUPATIONAL SAFETY AND/OR HEALTH LAWS OR REGULATIONS. IN NO EVENT SHALL ROSS BE LIABLE TO PURCHASER, USER, THEIR EMPLOYEES OR OTHERS FOR INCIDENTAL OR CONSEQUENTIAL DAMAGES WHICH MAY RESULT FROM A BREACH OF THE WARRANTY DESCRIBED ABOVE OR THE USE OR MISUSE OF THE PRODUCTS. NO STATEMENT OF ANY REPRESENTATIVE OR EMPLOYEE OF ROSS SHALL EXTEND THE LIABILITY OF ROSS AS SET FORTH HEREIN.



**GLOBAL Reach with a LOCAL Touch<sup>SM</sup>**

**ROSS CONTROLS**

Troy, MI., U.S.A.

Telephone: + 1-248-764-1800

Fax: + 1-248-764-1850

In the United States:

Customer Service: 1-800-GET ROSS  
(438-7677)

Technical Service: 1-888-TEK-ROSS  
(835-7677)

[www.rosscontrols.com](http://www.rosscontrols.com)

**ROSS EUROPA GmbH**

Langen, Germany

Telephone: + 49-6103-7597-0

Fax: + 49-6103-74694

Email: [info@rosseuropa.com](mailto:info@rosseuropa.com)

[www.rosseuropa.com](http://www.rosseuropa.com)

**ROSS ASIA K.K.**

Kanagawa, Japan

Telephone: + 81-427-78-7251

Fax: + 81-427-78-7256

[www.rossasia.co.jp](http://www.rossasia.co.jp)

**ROSS UK Ltd.**

Birmingham, United Kingdom

Telephone: + 44-121-559-4900

Fax: + 44-121-559-5309

Email: [sales@rossuk.co.uk](mailto:sales@rossuk.co.uk)

**ROSS CONTROLS INDIA Pvt. Ltd.**

Chennai, India

Telephone: + 91-44-2624-9040

Fax: + 91-44-2625-8730

Email: [rossindia@airtelbroadband.in](mailto:rossindia@airtelbroadband.in)

**ROSS SOUTH AMERICA Ltda.**

São Paulo, Brazil CEP 09725-020

Telephone: + 55-11-4335-2200

Fax: + 55-11-4335-3888

Email: [vendas@ross-sulamerica.com.br](mailto:vendas@ross-sulamerica.com.br)

**DIMAFLUID s.a.s.**

Saint Ouen, France

Telephone: + 33-01-49-45-65-65

Fax: + 33-01-49-45-65-30

Email: [dimafluid@dimafluid.com](mailto:dimafluid@dimafluid.com)

[www.dimafluid.com](http://www.dimafluid.com)

**ROSS CONTROLS (CHINA) Ltd.**

Shanghai, China

Telephone: + 86-21-6915-7951

Fax: + 86-21-6915-7960

Email: [alvinzhurong@vip.163.com](mailto:alvinzhurong@vip.163.com)

Your local ROSS distributor is:

**There are ROSS Distributors Throughout the World**

To meet your requirements across the globe, ROSS distributors are located throughout the world. Through ROSS or its distributors, guidance is available for the selection of ROSS products, both for those using pneumatic components for the first time and those designing complex pneumatic systems.

This catalog presents an overview of the extensive ROSS product line. Other literature is available for engineering, maintenance, and service requirements. If you need products or specifications not shown here, please contact ROSS or your ROSS distributor. They will be happy to assist you in selecting the best product for your application.