

**Series  
80 and 84  
SAE Standard  
Valves and Bases**

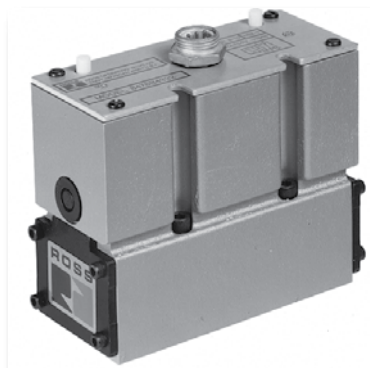

• *Manufacturers of Premium Pneumatic Controls since 1921* •



Consider it **DONE!**

# Contents

<b>Features of ROSS Series 80 &amp; 84 SAE Valves</b> .....	2
Features, Benefits, Applications .....	
<b>ROSS Valves for SAE Bases</b> .....	3-4
Series 84 Poppet Valve Construction .....	
Series 80 Spool Valve Construction .....	
<b>Series 80 Spool &amp; Sleeve Valves for SAE Bases</b> .....	5
5/2 Spool Valves .....	
5/3 Spool Valves .....	
<b>Series 84 Poppet Valves for SAE Bases</b> .....	6
Series 84 Poppet Valves .....	
<b>Sub-Bases for Series 80 &amp; 84 SAE Valves</b> .....	7
Side Ported .....	
<b>Manifolds for Series 80 &amp; 84 SAE Valves</b> .....	8-9
SAE Size 125 Manifold Stations .....	
SAE Size 250 Manifold Stations .....	
SAE Size 500 Manifold Stations .....	
<b>Accessories</b> .....	9-10
Manual Overrides Kits for SAE Size 500 Valve .....	
Interposed Regulators .....	
<b>CAUTIONS, WARRANTY</b> .....	11
<b>Global Locations</b> .....	12

*If you need products or specifications not shown within this bulletin, please contact ROSS for more information or visit ROSS website at [www.rosscontrols.com](http://www.rosscontrols.com).*

## Stainless Steel Spool & Sleeve- SAE 80 Series

### FEATURES

- Low shifting forces
- No wearing contact
- Balanced spool
- Mechanical detents
- Full 5-port design
- 2 or 3-position types
- No dynamic seals

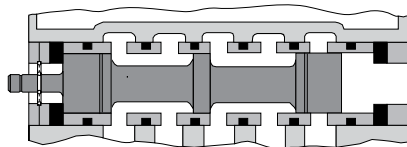

### BENEFITS

- Extremely long service life
- High cycle rates
- Fast response
- Use as 2-, 3-, 4-, or 5-way selector valve
- No seals to wear out
- Very low maintenance

Stainless steel spools move on an extremely thin film of air in the micro-inch clearance between spool and sleeve.

### APPLICATIONS

- On high-speed machines
- In food processing
- In dual-pressure circuits
- As little as 15 psi (1 bar) shifts spool

## Poppet- SAE 84 Series

Poppet surfaces face-seal against flat poppet seats.

### FEATURES

- Large pilot pistons
- Mechanical detents
- Self-cleaning
- Short stroke
- Viton seal option available
- Wear-compensating design.

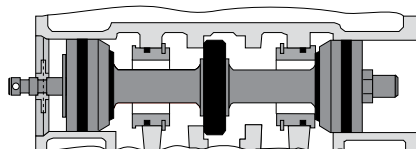

### BENEFITS

- Very dependable
- Tolerant of dirty air
- Positive seating
- Fast response
- Long service life
- Low maintenance
- Repeatability.

### APPLICATIONS

- Where there is no lubricated air
- Where the air is dirty (steel mills, glass plants, foundries, and aluminum smelters)
- High-speed machines
- High-temperature environments.

# ROSS Valves for SAE Bases

The SAE Standard Interface, though originally developed by U.S. auto companies in the early 1970s, has quickly gained wide acceptance throughout the industry. Due to the design's ruggedness and high-flow characteristics, the Society of Automotive Engineers (SAE) established it as a new standard. This ensures that valves designed to fit the SAE interface will be interchangeable, regardless of manufacturer. In practical terms, the user can change from one brand of valve to another without changing installed bases or manifolds.

ROSS valves are available in SAE sizes 125, 250 and 500. Both poppet and metal spool-and-sleeve construction are offered. The valves described in this bulletin are all solenoid-pilot controlled.

## SOLENOID PILOTS

**Internal or External Pilot Supply.** Valves in this bulletin are made for *internal* pilot supply. However, they are easily converted for use with an external pilot supply by moving a single pipe plug in the bottom of the valve.

With solenoid pilot control, the main valve is shifted by applying air pressure to an actuating piston or spool end. There is no mechanical connection between the solenoid plunger in the pilot and the main valve mechanism as there is in a valve actuated by a direct-acting solenoid. If the valve mechanism were to stick, the plunger in a solenoid-pilot-controlled valve could complete its travel and avoid the high current flow which results when the travel is incomplete. Thus overheating and solenoid burnout are avoided. Furthermore, under average shop conditions, air pressure produces a valve-shifting force much greater than that from a direct-acting solenoid, so that the problem of valve sticking is minimized.

**Indicator Lights.** An indicator light is wired to each solenoid circuit so that the light is illuminated whenever the solenoid is energized.

**Hard Wiring.** An electrical opening, threaded 1/2 NPSC, is available for use with conventional fittings.

## ELECTRICAL CONNECTORS

Electrical connections to the valves can be made with sealed 4 or 5-pin connectors (ANSI Standard B93.55) or by conventional hard wiring.

**Sealed Connector.** A 4 or 5-pin straight connector wired as required by either the Ford Motor Company or the Chrysler Corporation is available. Valves may be ordered with mini- or micro-change connectors. See the wiring diagrams below for the various options available.

**Ford Wired 5-pin mini-connector (all voltages)**

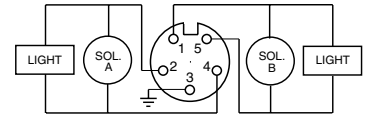

**Ford Wired 4-pin micro-connector (24 vdc)**

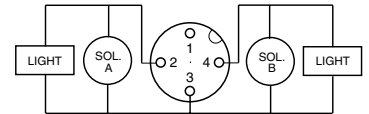

**Chrysler Wired 5-pin mini-connector (all voltages)**

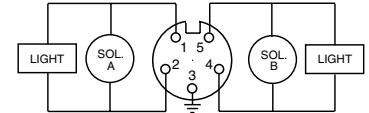

**Chrysler Wired 5-pin micro-connector (24 vdc)**

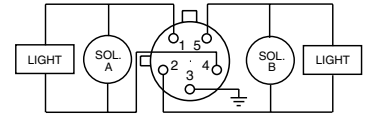

**Chrysler Wired 5-pin micro-connector (120 volts / 60 Hz)**

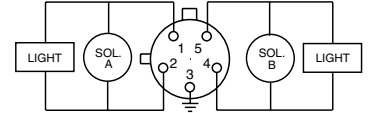

## Series 84 Poppet Valve Construction

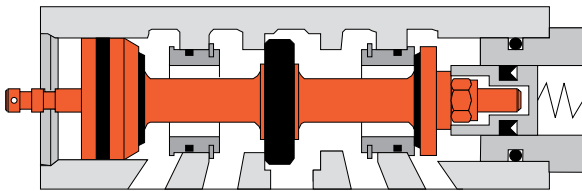

**Single Control.** 5-port, 2-position (5/2) valves that require a maintained signal to keep the valve in its shifted position. Internal air pressure provides the force to return the valve when the signal is removed.

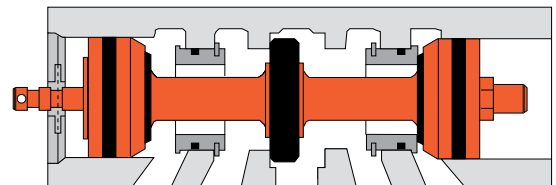

**Double Control.** 5-port, 2-position (5/2) valves that require only a momentary signal to shift the valve in either direction. A mechanical detent and differential air pressure keep the valve in its shifted position.



## MANUAL OVERRIDES

Each solenoid pilot has a non-locking override button for manual actuation of the valve. For Size 500 valves, locking buttons and extended buttons are also available. See page 9.

## VALVE RESPONSE TIME

Average response constants for each valve are listed in the charts on pages 4 thru 6. These constants, designated M and F, can be used to determine the amount of time required to fill or exhaust a volume of any size by using the following formula:

$$\text{Valve Response Time (msec)} = M + (F \cdot V)$$

In this formula, M represents the average time in milliseconds (msec) for the valve parts to move after the valve is energized. F is the average number of milliseconds required for a flow of one standard cubic inch through the valve. V is the number of cubic inches in the volume to be filled or exhausted.

The valve response time given by this formula is the average number of milliseconds required to fill the volume V to 90 per cent of supply pressure, or to exhaust the volume to 10 per cent of supply pressure. Response times will be valid for any pressure in the range specified for the valve under "Standard Specifications."

Note that F values are listed under two headings: "In-Out" and "Out-Exh." The In-Out values are used to calculate *fill* times, and the Out-Exh. values are used to calculate *exhaust* times.

**SAMPLE PROBLEM.** Using a ROSS double solenoid size 250 poppet valve, how long will it take to fill a 250-cubic-inch chamber to 90% of supply pressure?

**SOLUTION.** The poppet valves are described on page 4 of this bulletin. From the chart at the bottom of the page, we find that the response constants for a size 250 valve are M = 20 and F = 0.54. Using these values in the response time formula we have:

$$\begin{aligned} \text{Valve Response Time (msec)} &= 20 + (0.54)(250) \\ &= 20 + 135 \\ &= 155 \text{ msec} \end{aligned}$$

## FLOW RATINGS

**IMPORTANT NOTE.** Widely different test standards are used by different manufacturers in the determination of Cv ratings of valves. For this reason, the Cv values given in the charts on pages 4, 5, and 6 should not be used in comparing ROSS valves with those of other makers. These Cv values are intended only for use with performance charts published by ROSS.

The Cv ratings in the charts on pages 4, 5, and 6 are averages for the various flow paths through the valve and are for steady flow conditions.

## PORT IDENTIFICATION

Ports on bases and in diagrams are designated by the following letters:

- P: Inlet port
- A: Outlet port
- B: Outlet port
- EA: Exhaust port (from port A)
- EB: Exhaust port (from port B)
- X: External pilot supply port

## SERIES 80 Spool Valve Construction

The matched spool and sleeve used in each of these valves is made of precision finished, hardened, stainless steel. The spool moves on a micro-inch film of air between spool and sleeve so that wear is minimized. For use in systems with or without air line lubrication.

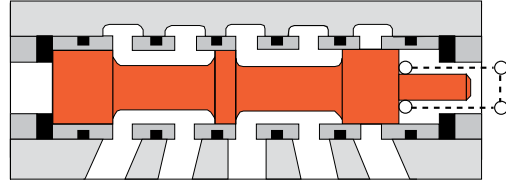

**Single Control.** 5-port, 2-position (5/2) valves require a maintained signal to keep the valve shifted. A spring provides the return force after the signal is removed.

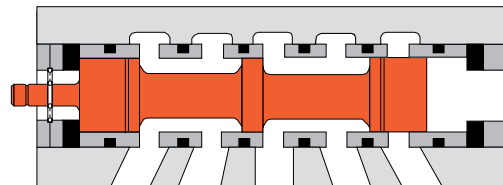

**Double Momentary Control.** 5-port, 2-position (5/2) valves require only a momentary signal to shift the valve in either direction. A mechanical detent keeps the valve in its shifted position.

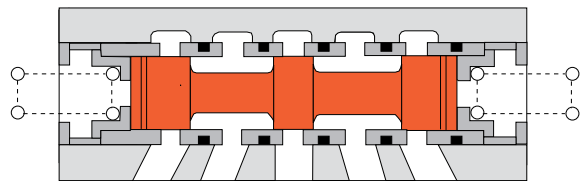

**Closed Center, Double Control.** 5-port, 3-position (5/3) valves require a maintained signal to shift the valve in either direction from center. In the center position all ports are closed.

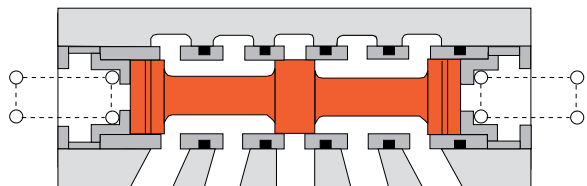

**Open Center, Double Control.** 5-port, 3-position (5/3) valves require a maintained signal to shift the valve in either direction from center. In the center position the outlet ports are connected to the exhaust ports and the inlet port is closed.

# Series 80 Spool & Sleeve Valves for SAE Bases

## 5/2 Spool Valves

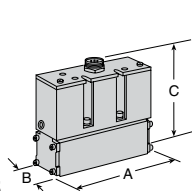

SAE Size 125  
Single or Double Solenoid

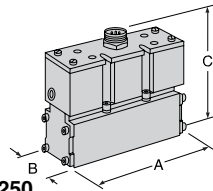

SAE Size 250  
Single or Double Solenoid

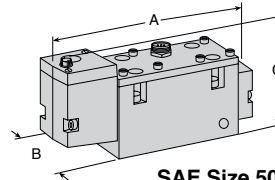

SAE Size 500  
Single Solenoid

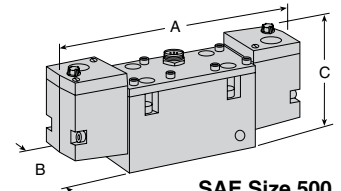

SAE Size 500  
Double Solenoid

### Valve Model Numbers (Base not included)

SAE Size	Type of Wiring			Avg. $C_v$	Dimensions inches (mm)			Weight lb (kg)
	Ford	Chrysler	Hardwire		A	B	C	
<b>Single Solenoid Pilot Valves</b>								
125	8076C3331	8076C3341	8076C3351	1.4	5.5 (140)	1.8 (45)	5.1 (129)	3.5 (1.6)
250	8076C4331	8076C4341	8076C4351	4.0	7.3 (185)	2.6 (65)	5.6 (142)	6.5 (2.9)
500	8076C6331	8076C6341	8076C6351	8.2	10.1 (257)	3.0 (76)	4.8 (121)	8.3 (3.7)
<b>Double Solenoid Pilot Valves</b>								
125	8076C3332	8076C3342	8076C3352	1.4	5.5 (140)	1.8 (45)	5.1 (129)	3.5 (1.6)
250	8076C4332	8076C4342	8076C4352	4.0	7.3 (185)	2.6 (65)	5.6 (142)	7.0 (3.2)
500	8076C6332	8076C6342	8076C6352	8.0	11.2 (285)	3.0 (76)	4.8 (121)	9.5 (4.3)

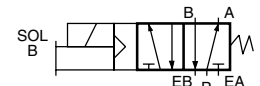

Single Solenoid



Double Solenoid

\*Bases and manifolds on pages 7-9.

## 5/3 Spool Valves

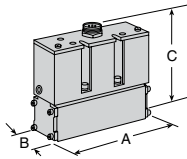

SAE Size 125  
Double Solenoid

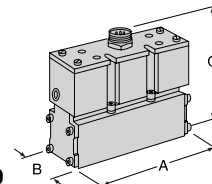

SAE Size 250  
Double Solenoid

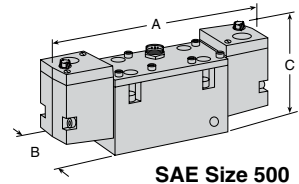

SAE Size 500  
Double Solenoid

### Valve Model Numbers (Base not included)

SAE Size	Type of Wiring			Avg. $C_v$	Dimensions inches (mm)			Weight lb (kg)
	Ford	Chrysler	Hardwire		A	B	C	
<b>Power Center Solenoid Pilot Valves</b>								
125	8077C3910	8077C3904	—	1.4	5.5 (140)	1.8 (45)	5.1 (129)	3.5 (1.6)
250	8077C4907	8077C4904	—	4.0	7.3 (185)	2.6 (65)	5.6 (142)	6.5 (2.9)
<b>Open Center Solenoid Pilot Valves</b>								
125	8077C3332	8077C3342	8077B3352	1.4	5.5 (140)	1.8 (45)	5.1 (129)	3.5 (1.6)
250	8077C4332	8077C4342	8077B4352	4.0	7.3 (185)	2.6 (65)	5.6 (142)	7.0 (3.2)
500	8077C6332	8077C6342	8077B6352	8.0	12.0 (306)	3.0 (76)	4.8 (121)	9.5 (4.3)
<b>Closed Center Solenoid Pilot Valves</b>								
125	8077C3331	8077C3341	8077B3351	1.4	5.5 (140)	1.8 (45)	5.1 (129)	3.5 (1.6)
250	8077C4331	8077C4341	8077B4351	4.0	7.3 (185)	2.6 (65)	5.6 (142)	7.0 (3.2)
500	8077C6331	8077C6341	8077B6351	8.0	12.0 (306)	3.0 (76)	4.8 (121)	9.5 (4.3)

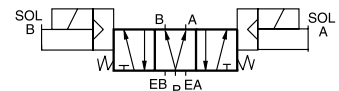

Power Center

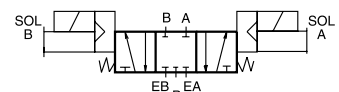

Closed Center

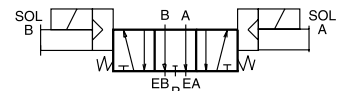

Open Center

\*Bases and manifolds on pages 7-9.

**STANDARD SPECIFICATIONS:** For valves on this page.

**Solenoids:** AC or DC power. Rated for continuous duty.

**Standard Voltages:**

SAE Size 125, 250 models: 100-110 volts, 50 Hz; 100-120 volts, 60 Hz; 24 volts DC; 110 volts DC. For other voltages, consult ROSS.

SAE Size 500 models: 100-110 volts, 50 Hz; 100-120 volts, 60 Hz; 24 volts DC; 110 volts DC. For other voltages, consult ROSS.

**Power Consumption:** Each solenoid:

SAE Size 125, 250 models: 8 VA inrush; 6 VA holding on 50/60 Hz; 8 watts on DC.

SAE Size 500 models: 87 VA inrush; 30 VA holding on 50/60 Hz; 14 watts on DC.

**Indicator Light:** One for each solenoid.

**Ambient Temperature:** 40° to 120°F (4° to 50°C).

**Media Temperature:** 40° to 175°F (4° to 80°C).

**Flow Media:** Filtered air; 5 micron recommended.

**Inlet Pressure:** Vacuum to 150 psig (10 bar).

**Pilot Pressure:** At least 15 psig (1 bar).

**Options:** Pressure Controlled Valves—Interposed Pressure Regulators.

### IMPORTANT NOTE

Please read carefully and thoroughly all of the **CAUTIONS** on the inside back cover.



# Series 84 Poppet Valves for SAE Bases

## Series 84 Poppet Valves

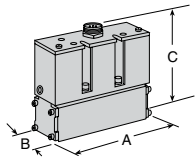

SAE Size 125  
Single or Double Solenoid

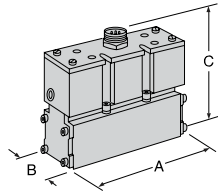

SAE Size 250  
Single or Double Solenoid

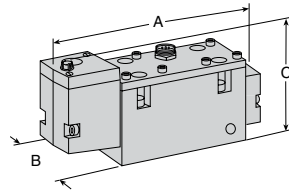

SAE Size 500  
Single Solenoid

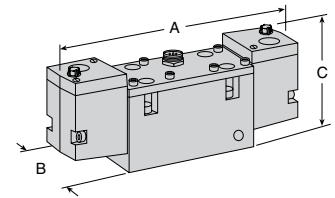

SAE Size 500  
Double Solenoid



Single Solenoid

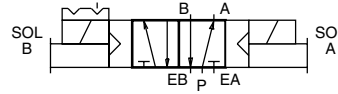

Double Solenoid

### Valve Model Numbers (Base not included)

SAE Size	Ford	Type of Wiring		Avg. $C_v$	Dimensions inches (mm)			Weight lb (kg)
		Chrysler	Hardwire		A	B	C	
<b>Single Solenoid Pilot Valves</b>								
125	8476C3331	8476C3341	8476C3351	1.8	5.5 (140)	1.8 (45)	5.1 (129)	2.8 (1.3)
250	8476C4331	8476C4341	8476C4351	5.5	7.3 (185)	2.6 (65)	5.6 (142)	5.2 (2.4)
500	8476C6331	8476C6341	8476C6351	7.9	10.1(257)	3.0 (76)	4.8 (121)	7.7 (3.5)
<b>Double Solenoid Pilot Valves</b>								
125	8476C3332	8476C3342	8476C3352	1.8	5.5 (140)	1.8 (45)	5.1 (129)	3.3 (1.5)
250	8476C4332	8476C4342	8476C4352	5.7	7.3 (185)	2.6 (65)	5.6 (142)	5.7 (2.6)
500	8476C6332	8476C6342	8476C6352	7.6	11.2 (285)	3.0 (76)	7.1 (180)	8.9 (4.1)

\* Bases and manifolds on pages 7-9.

### IMPORTANT NOTE:

The  $C_v$  values given in this publication should not be used in comparing ROSS valves with those of other makers. These  $C_v$  values are intended only for use with performance charts published by ROSS. The  $C_v$  ratings listed in this bulletin are averages for the various flow paths through the valve and are for steady flow conditions.

**STANDARD SPECIFICATIONS:** For valves on this page.

**Solenoids:** AC or DC power. Rated for continuous duty.

**Standard Voltages:**

SAE Size 125, 250 models: 100-110 volts, 50 Hz; 100-120 volts, 60 Hz; 24 volts DC; 110 volts DC. For other voltages, consult ROSS.

SAE Size 500 models: 100-110 volts, 50 Hz; 100-120 volts, 60 Hz; 24 volts DC; 110 volts DC. For other voltages, consult ROSS.

**Power Consumption:** Each solenoid:

SAE Size 125, 250 models: 8 VA inrush; 6 VA holding on 50/60 Hz; 8 watts on DC.

SAE Size 500 models: 87 VA inrush; 30 VA holding on 50/60 Hz; 14 watts on DC.

**Indicator Light:** One for each solenoid.

**Ambient Temperature:** 40° to 120°F (4° to 50°C).

**Media Temperature:** 40° to 175°F (4° to 80°C).

**Flow Media:** Filtered air; 5 micron recommended.

**Inlet Pressure:** 30 to 150 psig (10 bar).

**Pilot Pressure:** Must be equal to or greater than inlet pressure.

**Options:** Pressure Controlled Valves—Interposed Pressure Regulators.

### IMPORTANT NOTE

Please read carefully and thoroughly all of the **CAUTIONS** on the inside back cover.

# Sub-Bases for Series 80 & 84 SAE Valves

## Side-Ported

### SAE Size 125

Dimensions: inches (mm)

Sub-Base Number	Port Size*	
	A, B	P, EA, EB
577K91	1/8	1/4
578K91	1/4	3/8
579K91	3/8	3/8

\*NPT threads. For SAE threads, consult ROSS.

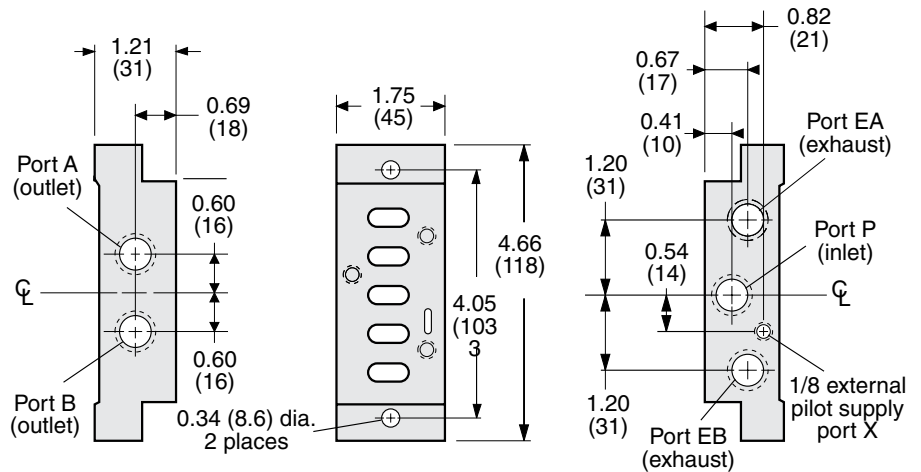

### SAE Size 250

Sub-Base Number	Port Size*	
	A, B	P, EA, EB
539K91	1/4	3/8
540K91	3/8	1/2
541K91	1/2	1/2
542K91	3/4	3/4

\*NPT threads. For SAE threads, consult ROSS.

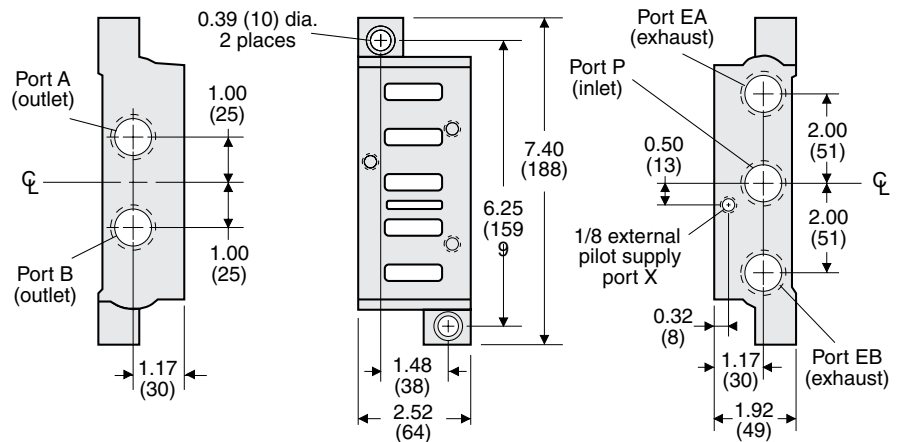

### SAE Size 500

Sub-Base Number	Port Size*	
	A, B	P, EA, EB
582K91	1/2	3/4
728K91	3/4	3/4
583K91	3/4	1
584K91	1	1

\*NPT threads. For SAE threads, consult ROSS.

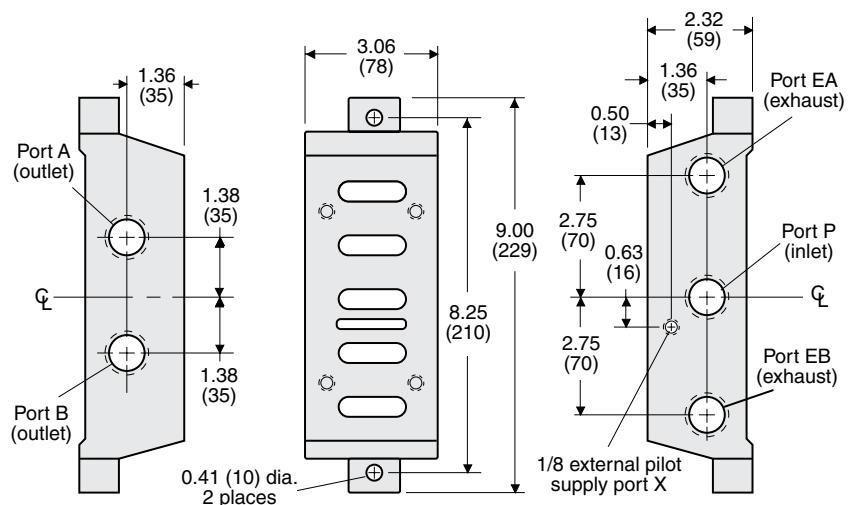

# Manifolds for Series 80 & 84 SAE Valves

## SAE Size 125 Manifold Stations

Dimensions: inches (mm)

Station Number	Port Sizes*	
	A, B	P, EA, EB
580K91	1/4	3/8
581K91	3/8	3/8

\*NPT threads. For SAE threads, consult ROSS.

Each manifold station is supplied with all necessary seals and hardware for assembly. End plates are *not* required with these manifolds. Each station has all ports threaded to accept piping.

**Blanking Plate:** For manifold stations not occupied by a valve, blanking plates are available. These plates block the unused air passages. Order by part number **820K77**.

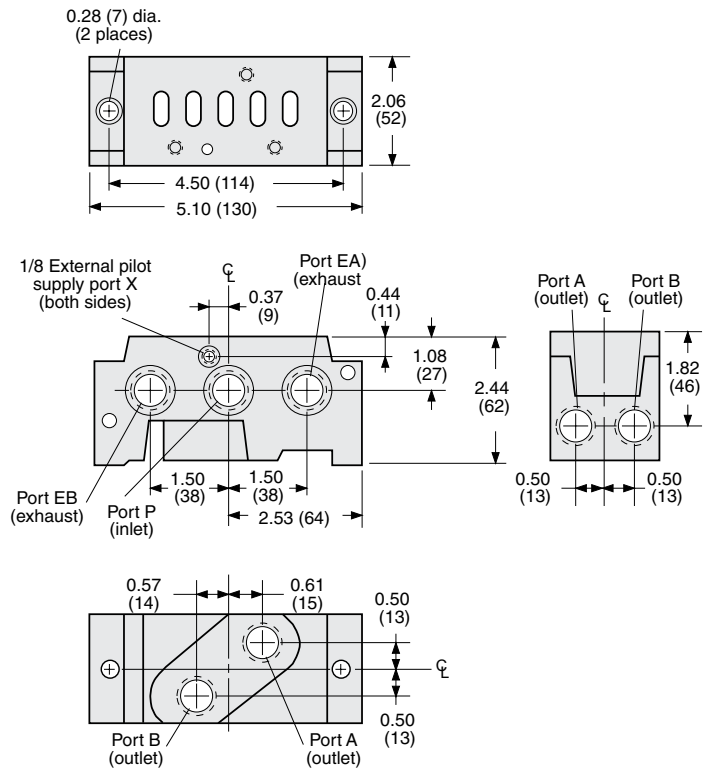

## SAE Size 250 Manifold Stations

Station Number	Port Sizes*	
	A, B	P, EA, EB
553K91	3/8	1/2
554K91	1/2	3/4
555K91	3/4	3/4

\*NPT threads. For SAE threads, consult ROSS.

Each manifold station is supplied with all necessary seals and hardware for assembly. End plates are *not* required with these manifolds. Each station has all ports threaded to accept piping.

**Blanking Plate:** For manifold stations not occupied by a valve, blanking plates are available. These plates block the unused air passages. Order by part number **821K77**.

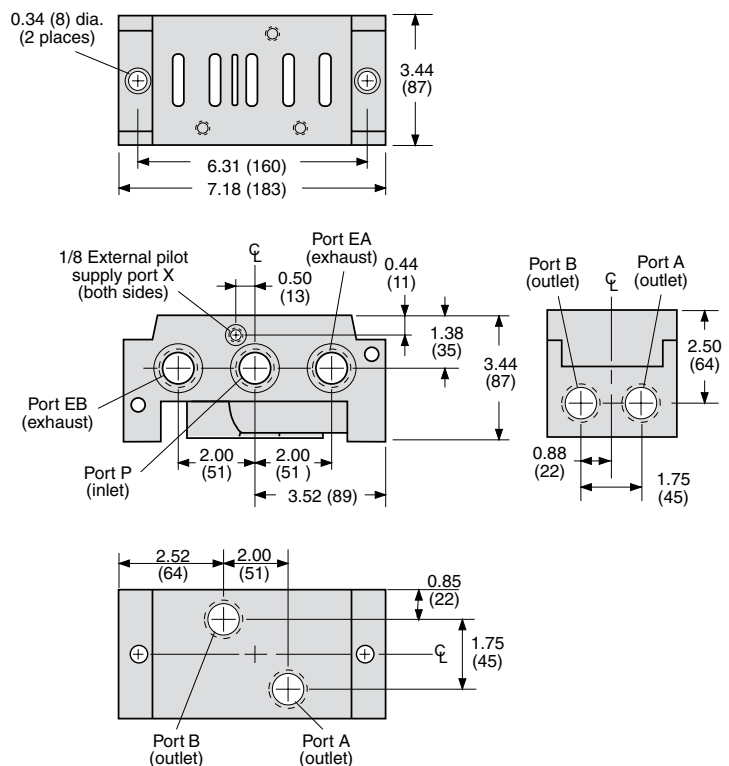

# Manifolds for Series 80 & 84 SAE Valves

## SAE Size 500 Manifold Stations

Dimensions: inches (mm)

Station Number	Port Sizes*	
	A, B	P, EA, EB
585K91	1/2	3/4
586K91	3/4	1
587K91	1	1

\*NPT threads. For SAE threads, consult ROSS.

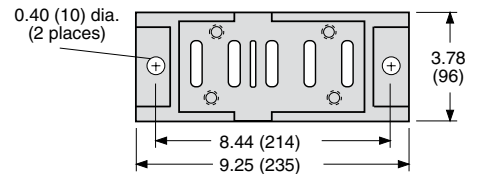

Each manifold station is supplied with all necessary seals and hardware for assembly. End plates are *not* required with these manifolds. Each station has all ports threaded to accept piping.

**Blanking Plate:** For manifold stations not occupied by a valve, blanking plates are available. These plates block the unused air passages. Order by part number **822K77**.

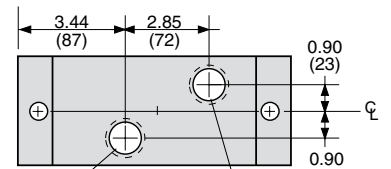
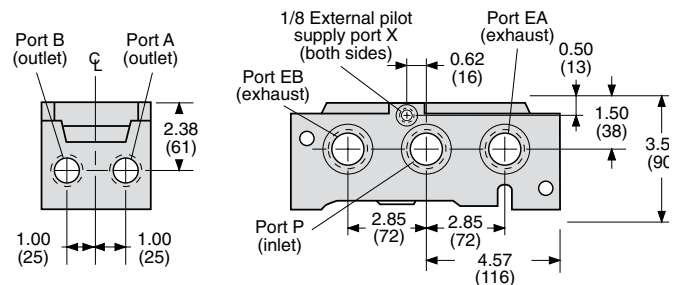

## Accessories

### Manual Override Kits for SAE Size 500 Valve

Flush metal buttons (shown at left as installed) are of either the locking or non-locking type. The extended button (see below) is the non-locking type.

Order by the kit numbers below:

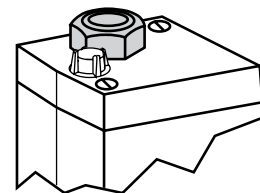

#### Flush Button

Non-locking 790K87  
Locking 792K87

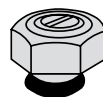

#### Extended Button

Non-locking 791K87

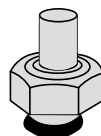

# Accessories

## Interposed Regulators

Both single and dual interposed regulators are available for SAE sizes 125 and 250.

A regulator is sandwiched between the valve and sub-base or manifold station and the valve is then bolted through the regulator to the sub-base or manifold station with the longer bolts provided.

Single pressure regulators supply the same regulated pressure at both outlet ports.

Dual pressure regulators allow the pressure at each outlet port to be set independently.

*Use dual pressure regulators with 80 Series valves only. When using dual pressure regulators, the valve must be externally piloted.*

Regulated pressure range:

10 – 130 psig (regulator-to-base gasket included).

**SAE Size 125 – Single: 593K91**

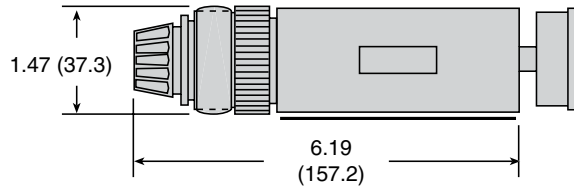

**SAE Size 250 – Single: 595K91**

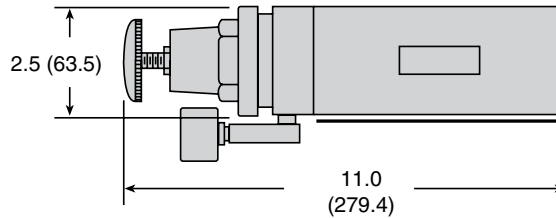

**SAE Size 125 – Dual: 873H91**

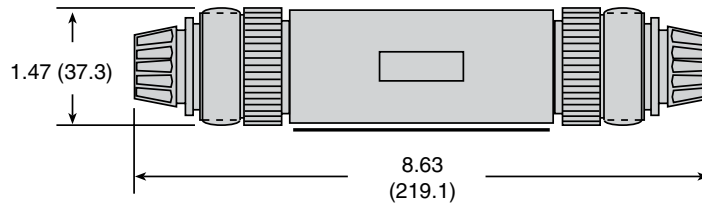

**SAE Size 250 – Dual: 816H91**

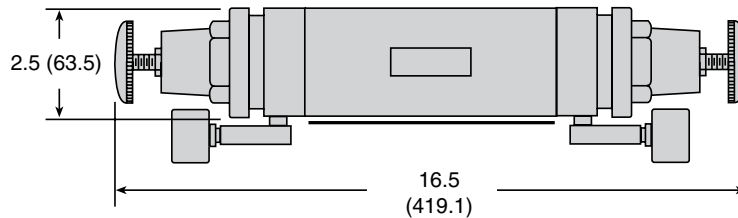

# Cautions

## PRE-INSTALLATION or SERVICE

1. Before servicing a valve or other pneumatic component, be sure that all sources of energy are turned off, the entire pneumatic system is shut off and exhausted, and all power sources are locked-out (ref: OSHA 1910.147, EN 1037).
2. All ROSS products, including service kits and parts, should be installed and/or serviced only by persons having training and experience with pneumatic equipment. Because any installation can be tampered with or need servicing after installation, persons responsible for the safety of others or the care of equipment must check every installation on a regular basis and perform all necessary maintenance.
3. All applicable instructions should be read and complied with before using any fluid power system in order to prevent harm to persons or equipment. In addition, overhauled or serviced valves must be functionally tested prior to installation and use.
4. Each ROSS product should be used within its specification limits. In addition, use only ROSS parts to repair ROSS products. Failure to follow these directions can adversely affect the performance of the product or result in the potential for human injury.

## FILTRATION and LUBRICATION

5. Dirt, scale, moisture, etc. are present in virtually every air system. Although some valves are more tolerant of these contaminants than others, best performance will be realized if a filter is installed to clean the air supply, thus preventing contaminants from interfering with the proper performance of the equipment. ROSS recommends a filter with a 5-micron rating for normal applications.
6. All standard ROSS filters and lubricators with polycarbonate plastic bowls are designed for compressed air applications only. Do *not* fail to use the metal bowl guard, where provided, to minimize danger from high pressure fragmentation in the event of bowl failure. Do not expose these products to certain fluids, such as alcohol or liquefied petroleum gas, as they can cause bowls to rupture, creating a combustible condition, hazardous leakage, and the potential for human injury. Immediately replace a crazed, cracked, or deteriorated bowl. When bowl gets dirty, replace it or wipe it with a clean dry cloth.

7. Only use lubricants which are compatible with materials used in the valves and other components in the system. Normally, compatible lubricants are petroleum base oils with oxidation inhibitors, an aniline point between 180°F (82°C) and 220°F (104°C), and an ISO 32, or lighter, viscosity. Avoid oils with phosphate type additives which can harm polyurethane components, potentially leading to valve failure and/or human injury. If you have questions regarding whether a lubricant used on your system is compatible with ROSS products, please contact ROSS.

## AVOID INTAKE/EXHAUST RESTRICTION

8. Do not restrict the air flow in the supply line. To do so could reduce the pressure of the supply air below the minimum requirements for the valve and thereby cause erratic action.
9. Do not restrict a valve's exhaust port as this can adversely affect its operation. Exhaust silencers must be resistant to clogging and have flow capacities at least as great as the exhaust capacities of the valves. Contamination of the silencer can result in reduced flow and increased back pressure.

*ROSS expressly disclaims all warranties and responsibility for any unsatisfactory performance or injuries caused by the use of the wrong type, wrong size, or inadequately maintained silencer installed with a ROSS product.*

## POWER PRESSES

10. Mechanical power presses and other potentially hazardous machinery using a pneumatically controlled clutch and brake mechanism must use a press control double valve with a monitoring device. A double valve without a self-contained monitoring device should be used only in conjunction with a control system which assures monitoring of the valve. All double valve installations involving hazardous applications should incorporate a monitoring system which inhibits further operation of the valve and machine in the event of a failure within the valve mechanism.

## ENERGY ISOLATION/EMERGENCY STOP

11. Per specifications and regulations, ROSS **L-O-X**® and manual **L-O-X**® with **EEZ-ON**® operation products are defined as energy isolation devices, NOT AS EMERGENCY STOP DEVICES.

# WARRANTY

Products manufactured by ROSS are warranted to be free of defects in material and workmanship for a period of one year from the date of purchase. ROSS' obligation under this warranty is limited to repair or replacement of the product or refund of the purchase price paid solely at the discretion of ROSS and provided such product is returned to ROSS freight prepaid and upon examination by ROSS is found to be defective. This warranty shall be void in the event that product has been subject to misuse, misapplication, improper maintenance, modification or tampering. THE WARRANTY EXPRESSED ABOVE IS IN LIEU OF AND EXCLUSIVE OF ALL OTHER WARRANTIES AND ROSS EXPRESSLY DISCLAIMS ALL OTHER WARRANTIES EITHER EXPRESSED OR IMPLIED WITH RESPECT TO MERCHANTABILITY OR FITNESS FOR A PARTICULAR PURPOSE. ROSS MAKES NO WARRANTY WITH RESPECT TO ITS PRODUCTS MEETING THE PROVISIONS OF ANY GOVERNMENTAL OCCUPATIONAL SAFETY AND/OR HEALTH LAWS OR REGULATIONS. IN NO EVENT SHALL ROSS BE LIABLE TO PURCHASER, USER, THEIR EMPLOYEES OR OTHERS FOR INCIDENTAL OR CONSEQUENTIAL DAMAGES WHICH MAY RESULT FROM A BREACH OF THE WARRANTY DESCRIBED ABOVE OR THE USE OR MISUSE OF THE PRODUCTS. NO STATEMENT OF ANY REPRESENTATIVE OR EMPLOYEE OF ROSS SHALL EXTEND THE LIABILITY OF ROSS AS SET FORTH HEREIN.





**GLOBAL Reach with a LOCAL Touch<sup>SM</sup>**

**ROSS CONTROLS**

Troy, MI., U.S.A.

Telephone: + 1-248-764-1800

Fax: + 1-248-764-1850

In the United States:

Customer Service: 1-800-GET ROSS

(438-7677)

Technical Service: 1-888-TEK-ROSS

(835-7677)

www.rosscontrols.com

**ROSS EUROPA GmbH**

Langen, Germany

Telephone: + 49-6103-7597-0

Fax: + 49-6103-74694

Email: info@rosseuropa.com

www.rosseuropa.com

**ROSS ASIA K.K.**

Kanagawa, Japan

Telephone: + 81-427-78-7251

Fax: + 81-427-78-7256

www.rossasia.co.jp

**ROSS UK Ltd.**

Birmingham, United Kingdom

Telephone: + 44-121-559-4900

Fax: + 44-121-559-5309

Email: sales@rossuk.co.uk

**ROSS CONTROLS INDIA Pvt. Ltd.**

Chennai, India

Telephone: + 91-44-2624-9040

Fax: + 91-44-2625-8730

Email: rossindia@airtelbroadband.in

**ROSS SOUTH AMERICA Ltda.**

São Paulo, Brazil CEP 09725-020

Telephone: + 55-11-4335-2200

Fax: + 55-11-4335-3888

Email: vendas@ross-sulamerica.com.br

**DIMAFLUID s.a.s.**

Saint Ouen, France

Telephone: + 33-01-49-45-65-65

Fax: + 33-01-49-45-65-30

Email: dimafluid@dimafluid.com

www.dimafluid.com

**ROSS CONTROLS (CHINA) Ltd.**

Shanghai, China

Telephone: + 86-21-6915-7951

Fax: + 86-21-6915-7960

Email: alvinzhurong@vip.163.com

*Your local ROSS distributor is:*

***There are ROSS Distributors Throughout the World***

*To meet your requirements across the globe, ROSS distributors are located throughout the world. Through ROSS or its distributors, guidance is available for the selection of ROSS products, both for those using pneumatic components for the first time and those designing complex pneumatic systems.*

*This catalog presents an overview of the extensive ROSS product line. Other literature is available for engineering, maintenance, and service requirements. If you need products or specifications not shown here, please contact ROSS or your ROSS distributor. They will be happy to assist you in selecting the best product for your application.*