

**Series
27, 21 and 16
Poppet Valves
for Line Mounting
and
Valves for Vacuum Service**



• *Manufacturers of Premium Pneumatic Controls since 1921* •



Consider it **DONE!**

Contents

Features of ROSS Line-Mount Valves	2
Series 27 Poppet Valves for Line Mounting	3
Features	
Series 27 Poppet Valves for Line Mounting	
Single Solenoid Pilot Controlled.....	4
Single Pressure Controlled	5
Double Direct Solenoid Controlled, Detented	6
Indicator Light Kit	6
Manual Override Kits	6
Series 21 Poppet Valves for Line Mounting	7
Series 21 Poppet Valves for Line Mounting	
Single Solenoid Pilot Controlled.....	8
Single Pressure Controlled	9
Double Direct Solenoid Controlled, Detented	10
What are Vacuum Service Valves?	10
Anatomy of a Vacuum Service Valve	11
Why a ROSS Vacuum Valve?	11
Series 21 Solenoid Pilot Controlled Vacuum Valves	12
Series 21 Pressure Controlled Vacuum Valves	13
Series 21 Solenoid Pilot Controlled Full Vacuum Valves	14
Series 16 Compact Poppet Valves, Line or Manifold Mounting	14, 15
CAUTIONS	15
WARRANTY	15
Global Locations	16

If you need products or specifications not shown within this bulletin, please contact ROSS for more information or visit ROSS website at www.rosscontrols.com.

Features of ROSS Line-Mount Valves

1. Low weight; compact size.
2. **LOGICAIR**® adaptors provide special functions:
 - Timed sequence actuation and/or deactuation
 - Momentary control of actuation/deactuation from one pressure source
 - Actuating force multiplier, for use with low signal pressures.
3. Available with choices of internal components for three different temperature ranges.
4. Choose from five flow patterns: 2/2 normally-open/-closed, 3/2 normally-open/closed, or 4/2 designs.
5. Port sizes up to 2½"; C_v ratings up to 70.
6. Can be mounted close to actuator, reducing length of pipe to be pressurized/exhausted on each cycle.
7. Long life expectancy.
8. Consistent response times over the life of the valve.



Series 27 Poppet Valves for Line Mounting

Series 27 Poppet valves for line mounting are available with single or double solenoid pilot control, or an air head for pressure control. Valve elements have end-guided stainless steel stems. Flush flexible manual override buttons are standard on solenoid models. Solenoid models listed in this catalog use an internal pilot supply. They are, however, easily field-convertible for use with an external pilot supply. Models for external pilot supply may also be ordered from ROSS.

FEATURES:

- Poppet construction for near zero leakage & high dirt tolerance
- Self-cleaning
- Wear compensating
- Repeatability throughout the life of the valve

To provide special control functions, most models are also available with the following **LOGICAIR®** adaptors.

Timed Sequence Adaptor: Allows the actuation and/or de-actuation of a valve to be delayed up to 30 seconds for 2/2 valves, and up to 3 seconds for 3/2 and 4/2 valves. For longer delays see “Q” adaptor below.

“PB” Adaptor: Increases the actuating force on the valve piston. Useful with low pilot pressure.

Air Index Adaptor: Allows a single control valve to function as an impulse controlled, detented valve. Successive momentary signals from the same source actuate and de-actuate the valve.

“Q” Adaptor: For use in conjunction with the timed sequence adaptor to extend the delay interval up to 60 seconds. The “Q” adaptor also provides quicker response to actuating and de-actuating signals.

For additional information consult your ROSS distributor or call ROSS Technical Services in the U.S.A. at 1-888-TEK-ROSS (835-7677).



3/2 Valve with Single Solenoid Pilot Control

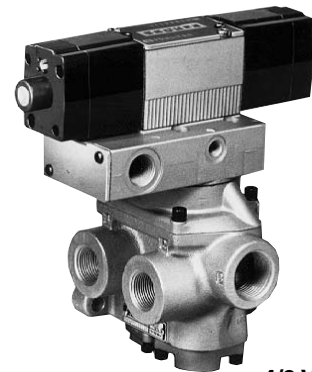

4/2 Valve with Double Solenoid Pilot Control

Series 27 Valve Bodies

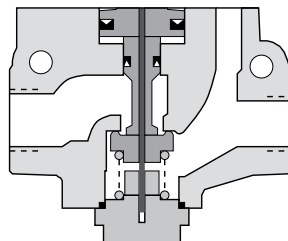

2/2 Normally Closed

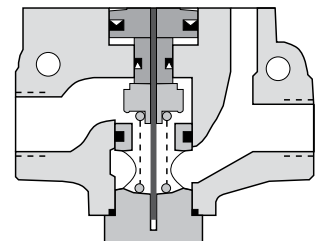

2/2 Normally Open

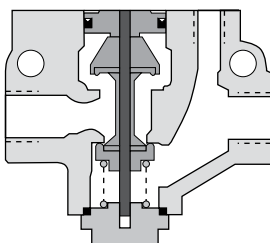

3/2 Normally Closed

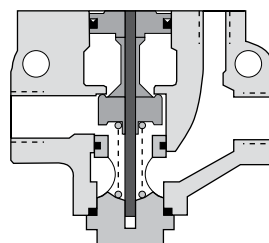

3/2 Normally Open

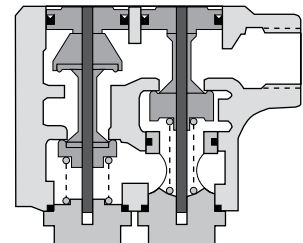

4/2

Series 27 Poppet Valves for Line Mounting

Single Solenoid Pilot Controlled

2/2 Valves

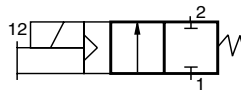

Normally Closed (NC)

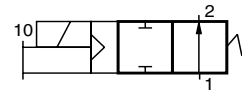

Normally Open (NO)

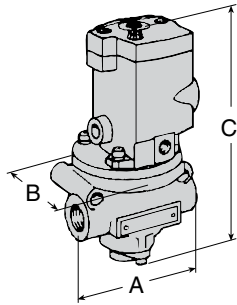

Port Size	Valve Model Number		Avg. C_v		Dimensions inches (mm)			Weight lb (kg)
	NC	NO	NC	NO	A	B	C	
1/4	2771B2001	2772B2001	2.3	2.3	3.6 (91)	3.2 (79)	6.9 (175)	2.5 (1.2)
3/8	2771B3001	2772B3001	3.8	3.3	3.6 (91)	3.2 (79)	6.9 (175)	2.5 (1.2)
1/2	2771B4011	2772B4011	4.0	3.5	3.6 (91)	3.2 (79)	6.9 (175)	2.5 (1.2)
1/2	2771B4001	2772B4001	7.7	6.5	4.6 (116)	3.2 (79)	7.6 (193)	3.3 (1.5)
3/4	2771B5001	2772B5001	9.0	7.3	4.6 (116)	3.2 (79)	7.6 (193)	3.3 (1.5)
1	2771B6011	2772B6011	9.0	7.9	4.6 (116)	3.2 (79)	7.6 (193)	3.3 (1.5)
1	2771B6001	2772B6001	24	21	6.7 (169)	4.1 (104)	10.4 (265)	7.0 (3.2)
1¼	2771B7001	2772B7001	29	20	6.7 (169)	4.1 (104)	10.4 (265)	7.0 (3.2)
1½	2771B8011	2772B8011	29	21	6.7 (169)	4.1 (104)	10.4 (265)	7.0 (3.2)
1½	2771B8001	2772B8001	49	49	8.7 (219)	5.2 (131)	11.8 (300)	15.5 (6.9)
2	2771B9001	2772B9001	57	57	8.7 (219)	5.2 (131)	11.8 (300)	15.5 (6.9)
2½	2771B9011	2772B9011	64	72	8.7 (219)	5.2 (131)	11.8 (300)	15.5 (6.9)

3/2 Valves

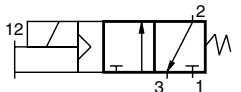

Normally Closed (NC)

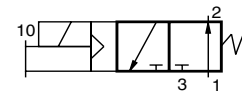

Normally Open (NO)

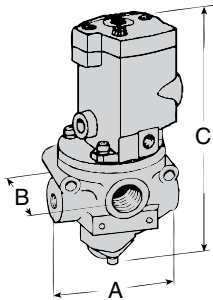

Port Sizes		Valve Model Number		Avg. C_v		Dimensions inches (mm)			Weight lb (kg)
In-Out	Exh.	NC	NO	NC	NO	A	B	C	
1/4	1/2	2773B2001	2774B2001	2.8	2.5	3.6 (91)	3.2 (79)	7.2 (182)	2.5 (1.2)
3/8	1/2	2773B3001	2774B3001	4.0	3.0	3.6 (91)	3.2 (79)	7.2 (182)	2.5 (1.2)
1/2	1/2	2773B4011	2774B4011	3.8	3.0	3.6 (91)	3.2 (79)	7.2 (182)	2.5 (1.2)
1/2	1	2773B4001	2774B4001	7.8	7.2	4.6 (116)	3.6 (92)	7.9 (201)	3.3 (1.5)
3/4	1	2773B5001	2774B5001	9.4	7.2	4.6 (116)	3.6 (92)	7.9 (201)	3.3 (1.5)
1	1	2773B6011	2774B6011	10	7.2	4.6 (116)	3.6 (92)	7.9 (201)	3.3 (1.5)
1	1½	2773B6001	2774B6001	29	21	6.7 (169)	4.9 (123)	10.4 (265)	7.0 (3.2)
1¼	1½	2773B7001	2774B7001	31	22	6.7 (169)	4.9 (123)	10.4 (265)	7.0 (3.2)
1½	1½	2773B8011	2774B8011	31	21	6.7 (169)	4.9 (123)	10.4 (265)	7.0 (3.2)
1½	2½	2773B8001	2774B8001	69	58	8.7 (219)	6.4 (161)	12.4 (313)	16.5 (7.4)
2	2½	2773B9001	2774B9001	70	60	8.7 (219)	6.4 (161)	12.4 (313)	16.5 (7.4)
2½	2½	2773B9011	2774B9011	71	55	8.7 (219)	6.4 (161)	12.4 (313)	16.5 (7.4)

4/2 Valves

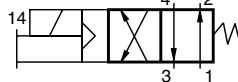
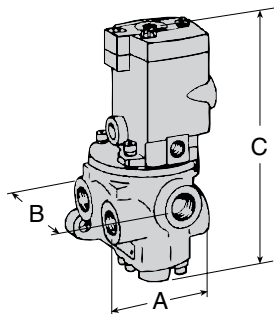

Port Sizes		Valve Model Number	Avg. C_v	Dimensions inches (mm)			Weight lb (kg)
In-Out	Exh.			A	B	C	
1/4	1/2	2776B2001	2.5	4.0 (100)	3.9 (97)	7.2 (182)	3.0 (1.4)
3/8	1/2	2776B3001	3.6	4.0 (100)	3.9 (97)	7.2 (182)	3.0 (1.4)
1/2	1/2	2776B4011	3.7	4.0 (100)	3.9 (97)	7.2 (182)	3.0 (1.4)
1/2	1	2776B4001	6.9	4.7 (118)	5.3 (135)	9.0 (228)	5.3 (2.4)
3/4	1	2776B5001	8.2	4.7 (118)	5.3 (135)	9.0 (228)	5.3 (2.4)
1	1	2776B6011	8.9	4.7 (118)	5.3 (135)	9.0 (228)	5.3 (2.4)
1	1½	2776B6001	23	6.5 (166)	8.3 (211)	10.7 (271)	11.3 (5.1)
1¼	1½	2776B7001	24	6.5 (166)	8.3 (211)	10.7 (271)	11.3 (5.1)
1½	1½	2776B8011	25	6.5 (166)	8.3 (211)	10.7 (271)	11.3 (5.1)

STANDARD SPECIFICATIONS: For valves on this page.

Solenoids: AC or DC power.

Standard Voltages: Consult ROSS.

Power Consumption: 87 VA inrush, 30 VA holding on 50 or 60 Hz; 14 watts on DC.

Ambient Temperature: 40° to 120°F (4° to 50°C).

Media Temperature: 40° to 175°F (4° to 80°C).

Flow Media: Filtered air; 5 micron recommended.

Inlet Pressure: 1/4 to 1½ Port Sizes: 15 to 150 psig (1 to 10 bar);

1½ to 2½ Port Sizes: 30 to 150 psig (2 to 10 bar).

Pilot Pressure: When external supply is used, pressure must be equal to or greater than inlet pressure.

Threads: Model numbers above specify NPT pressure port threads. For other threads, consult ROSS.

IMPORTANT NOTE: Please read carefully and thoroughly all of the **CAUTIONS** on the inside back cover.

Series 27 Poppet Valves for Line Mounting

Single Pressure Controlled

2/2 Valves

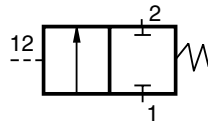

Normally Closed (NC)

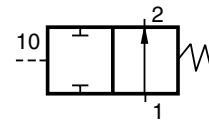

Normally Open (NO)

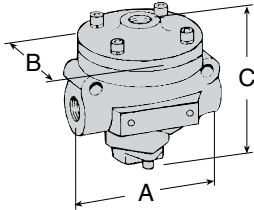

Port Size	Valve Model Number		Avg. C_v		Dimensions inches (mm)			Weight lb (kg)
	NC	NO	NC	NO	A	B	C	
1/4	2751A2001	2752A2001	2.3	2.3	3.6 (91)	3.2 (79)	3.8 (95)	1.3 (0.6)
3/8	2751A3001	2752A3001	3.8	3.3	3.6 (91)	3.2 (79)	3.8 (95)	1.3 (0.6)
1/2	2751A4011	2752A4011	4.0	3.5	3.6 (91)	3.2 (79)	3.8 (95)	1.3 (0.6)
1/2	2751A4001	2752A4001	7.7	6.5	4.6 (116)	3.2 (79)	4.5 (113)	2.0 (0.9)
3/4	2751A5001	2752A5001	9.0	7.3	4.6 (116)	3.2 (79)	4.5 (113)	2.0 (0.9)
1	2751A6011	2752A6011	9.0	7.9	4.6 (116)	3.2 (79)	4.5 (113)	2.0 (0.9)
1	2751A6001	2752A6001	24	21	6.7 (169)	4.1 (104)	7.5 (190)	8.0 (3.6)
1¼	2751A7001	2752A7001	29	20	6.7 (169)	4.1 (104)	7.5 (190)	8.0 (3.6)
1½	2751A8011	2752A8011	29	21	6.7 (169)	4.1 (104)	7.5 (190)	8.0 (3.6)
1½	2751A8001	2752A8001	49	49	8.7 (219)	5.2 (131)	9.0 (228)	14.3 (6.4)
2	2751A9001	2752A9001	57	57	8.7 (219)	5.2 (131)	9.0 (228)	14.3 (6.4)
2½	2751A9011	2752A9011	64	72	8.7 (219)	5.2 (131)	9.0 (228)	14.3 (6.4)

3/2 Valves

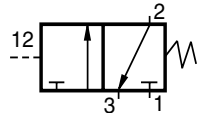

Normally Closed (NC)

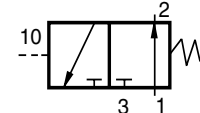

Normally Open (NO)

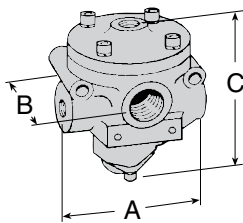

Port Sizes		Valve Model Number		Avg. C_v		Dimensions inches (mm)			Weight lb (kg)
In-Out	Exh.	NC	NO	NC	NO	A	B	C	
1/4	1/2	2753A2001	2754A2001	2.8	2.5	3.6 (91)	3.2 (79)	4.0 (101)	1.3 (0.6)
3/8	1/2	2753A3001	2754A3001	4.0	3.0	3.6 (91)	3.2 (79)	4.0 (101)	1.3 (0.6)
1/2	1/2	2753A4011	2754A4011	3.8	3.0	3.6 (91)	3.2 (79)	4.0 (101)	1.3 (0.6)
1/2	1	2753A4001	2754A4001	7.8	7.2	4.6 (116)	3.6 (92)	4.8 (121)	2.0 (0.9)
3/4	1	2753A5001	2754A5001	9.4	7.2	4.6 (116)	3.6 (92)	4.8 (121)	2.0 (0.9)
1	1	2753A6011	2754A6011	10	7.2	4.6 (116)	3.6 (92)	4.8 (121)	2.0 (0.9)
1	1½	2753A6001	2754A6001	29	21	6.7 (169)	4.9 (123)	7.5 (190)	6.0 (2.7)
1¼	1½	2753A7001	2754A7001	31	22	6.7 (169)	4.9 (123)	7.5 (190)	6.0 (2.7)
1½	1½	2753A8011	2754A8011	31	21	6.7 (169)	4.9 (123)	7.5 (190)	6.0 (2.7)
1½	2½	2753A8001	2754A8001	69	58	8.7 (219)	6.4 (161)	9.5 (241)	15.3 (6.9)
2	2½	2753A9001	2754A9001	70	60	8.7 (219)	6.4 (161)	9.5 (241)	15.3 (6.9)
2½	2½	2753A9011	2754A9011	71	55	8.7 (219)	6.4 (161)	9.5 (241)	15.3 (6.9)

4/2 Valves

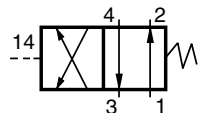
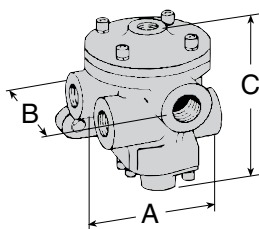

Port Sizes		Valve Model Number	Avg. C_v	Dimensions inches (mm)			Weight lb (kg)
In-Out	Exh.	Number	C_v	A	B	C	
1/4	1/2	2756A2001	2.5	4.0 (100)	3.9 (97)	4.0 (101)	1.8 (0.8)
3/8	1/2	2756A3001	3.6	4.0 (100)	3.9 (97)	4.0 (101)	1.8 (0.8)
1/2	1/2	2756A4011	3.7	4.0 (100)	3.9 (97)	4.0 (101)	1.8 (0.8)
1/2	1	2756A4001	6.9	4.7 (118)	5.3 (135)	5.8 (147)	4.3 (1.9)
3/4	1	2756A5001	8.2	4.7 (118)	5.3 (135)	5.8 (147)	4.3 (1.9)
1	1	2756A6011	8.9	4.7 (118)	5.3 (135)	5.8 (147)	4.3 (1.9)
1	1½	2756A6001	23	6.5 (166)	8.3 (211)	7.5 (190)	10.3 (4.6)
1¼	1½	2756A7001	24	6.5 (166)	8.3 (211)	7.5 (190)	10.3 (4.6)
1½	1½	2756A8011	25	6.5 (166)	8.3 (211)	7.5 (190)	10.3 (4.6)

STANDARD SPECIFICATIONS: For valves on this page.

Ambient/Media Temperature: 40° to 175°F (4° to 80°C).

Flow Media: Filtered air; 5 micron recommended.

Inlet Pressure: 1/4 to 1½ Port Sizes: 15 to 150 psig (1 to 10 bar).

1½ to 2½ Port Sizes: 30 to 150 psig (2 to 10 bar).

Pilot Pressure: Must be equal to or greater than inlet pressure.

Threads: Model numbers above specify NPT pressure port threads. For other threads, consult ROSS.

IMPORTANT NOTE: Please read carefully and thoroughly all of the **CAUTIONS** on the inside back cover.

Series 27 Poppet Valves for Line Mounting

4/2 Valves – Double Direct Solenoid Controlled, Detented

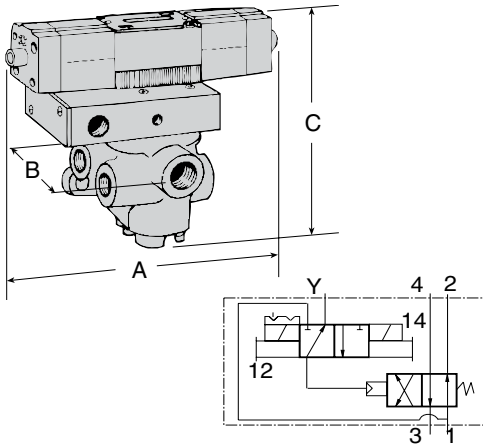

Port Sizes In-Out	Exh.	Valve Model Number	Avg. C _v	Dimensions inches (mm)			Weight lb (kg)
				A	B	C	
1/4	1/2	2776B2003	2.5	9.3 (236)	3.9 (97)	7.9 (201)	4.0 (1.8)
3/8	1/2	2776B3003	3.6	9.3 (236)	3.9 (97)	7.9 (201)	4.0 (1.8)
1/2	1/2	2776B4013	3.7	9.3 (236)	3.9 (97)	7.9 (201)	4.0 (1.8)
1/2	1	2776B4003	6.9	9.3 (236)	5.3 (135)	9.7 (246)	6.3 (2.8)
3/4	1	2776B5003	8.2	9.3 (236)	5.3 (135)	9.7 (246)	6.3 (2.8)
1	1	2776B6013	8.9	9.3 (236)	5.3 (135)	9.7 (246)	6.3 (2.8)
1	1½	2776B6003	23	9.3 (236)	8.3 (211)	11.6 (295)	12.3 (5.5)
1¼	1½	2776B7003	24	9.3 (236)	8.3 (211)	11.6 (295)	12.3 (5.5)
1½	1½	2776B8013	25	9.3 (236)	8.3 (211)	11.6 (295)	12.3 (5.5)

STANDARD SPECIFICATIONS: For valves listed above.

Solenoids: AC or DC power.

Standard Voltages: Consult ROSS.

Power Consumption: Each solenoid; 190 VA inrush, 40 VA holding on 50 or 60 Hz; 20 watts on DC.

Indicator Lights: In each solenoid housing.

Ambient Temperature: 40° to 120°F (4° to 50°C).

Media Temperature: 40° to 175°F (4° to 80°C).

Flow Media: Filtered air; 5 micron recommended.

Inlet Pressure: 15 to 150 psig (1 to 10 bar).

Pilot Pressure: If external supply is used, pressure must be equal to or greater than inlet pressure.

Threads: Model numbers above specify NPT pressure port threads. For other threads, consult ROSS.

IMPORTANT NOTE

Please read carefully and thoroughly all of the **CAUTIONS** on the inside back cover.

Indicator Light Kit

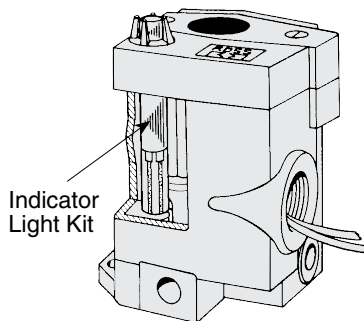

An indicator light extends through the solenoid or pilot cover and is illuminated when the solenoid is energized. Such lights are standard on double solenoid valves in Series 21 and 27.

An indicator light is available in kit form for single solenoid models in Series 16, Series 21 (type O only), and Series 27.

Order kit number **862K87** and specify the voltage of the solenoid.

Manual Override Kits

Flush flexible manual overrides are standard on single solenoid models in Series 16 and Series 27. Double solenoid models in Series 21 and 27 have flush metal-button overrides. Both types are non-locking.

Each of the buttons in the override kits below is made of metal and is spring-returned. The locking type button, however, can be kept in the actuated position by turning the slot in the top of the button with a screwdriver.

Order by the kit numbers shown below.

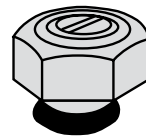

FLUSH BUTTON

Locking type Kit **792K87**
Non-locking type..... Kit **790K87**

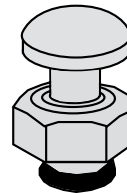

EXTENDED BUTTON WITH PALM ACTUATOR

Non-locking type..... Kit **984H87**

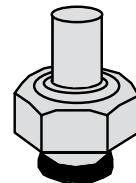

EXTENDED BUTTON

Non-locking type..... Kit **791K87**

Series 21 Poppet Valves for Line Mounting

Series 21

High Temperature and Low Temperature Service

Series 21 valves are configured like the Series 27 valves, but are designed with metal internals and special seals appropriate for use in more extreme temperatures. The valves are designated as either Type H (High Temperature) or Type O (Low Temperature) valves. Temperature specifications for the two types are given below.

Solenoid models listed in this catalog use an internal pilot supply. They are, however, easily field-convertible for use with an external pilot supply. Models for external pilot supply may also be ordered from ROSS.

Type H (High Temperature) Service: Fluorocarbon seals are used to ensure high temperature stability.

Ambient Temperature: Up to 250°F (122°C) for solenoid models; up to 300°F (150°C) for pressure controlled models.

Media Temperature: 0° to 300°F (-17° to 150°C).

Type O (Low Temperature) Service: Buna-N seals are used to ensure good performance at low temperatures.

Ambient Temperature: Down to -40°F (-40°C).

Media Temperature: -40° to 175°F (-40° to 80°C).

Vacuum Service: The construction of Series 21 valves makes them readily adaptable to vacuum service.

For additional information consult your ROSS distributor or call ROSS Technical Services in the U.S.A. at 1-888-TEK-ROSS (835-7677).



3/2 Valve with Single Solenoid Pilot
Metal override button on top of pilot is standard on all single solenoid models.

FEATURES:

- Poppet construction for near zero leakage & high dirt tolerance
- Self-cleaning
- Wear compensating
- Repeatability throughout the life of the valve

Series 21 Valve Bodies

O-ring piston seals have Teflon wear rings top and bottom. Inlet and exhaust poppets have spun-in O-ring seals.

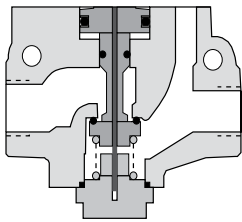

2/2 Normally Closed

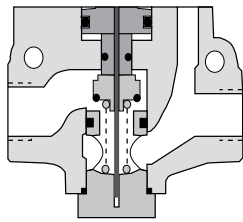

2/2 Normally Open

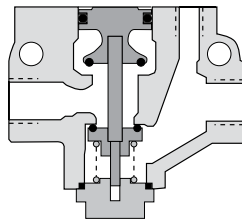

3/2 Normally Closed

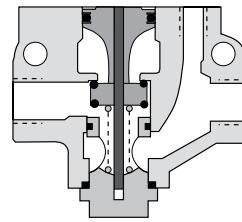

3/2 Normally Open

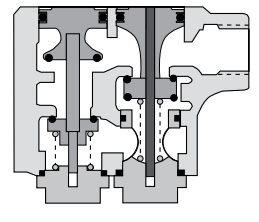

4/2

STANDARD SPECIFICATIONS: For valves on page 8.

Solenoids: AC or DC power.

Standard Voltages: Consult ROSS.

Power Consumption: 87 VA inrush, 30 VA holding on 50 or 60 Hz; 14 watts on DC.

Ambient Temperature: *Type H:* 0° to 250°F (-17° to 122°C).

Type O: -40° to 120°F (-40° to 50°C).

Media Temperature: *Type H:* 0° to 300°F (-17° to 150°C).

Type O: -40° to 175°F (-40° to 80°C).

For temperatures below 40°F (4°C) air must be free of water vapor to prevent formation of ice.

Flow Media: Filtered air; 5 micron recommended.

Inlet Pressure: 30 to 150 psig (2 to 10 bar).

Pilot Pressure: When external supply is used, pressure must be equal to or greater than inlet pressure.

Threads: Model numbers above specify NPT pressure port threads. For other threads, consult ROSS.

Manual Override: Non-locking metal button.



Series 21 Poppet Valves for Line Mounting

Single Solenoid Pilot Controlled 2/2 Valves

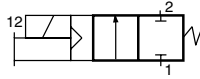
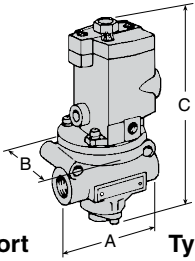

2/2 Normally Closed (NC)

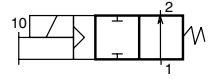

2/2 Normally Open (NO)

Port Size	Type H		Type O		Avg. C _v		Dimensions inches (mm)			Weight lb (kg)
	NC	NO	NC	NO	NC	NO	A	B	C	
1/4	2171B2001	2172B2001	2171B2002	2172B2002	2.3	2.3	3.6 (90)	3.0 (76)	7.0 (178)	3.0 (1.4)
3/8	2171B3001	2172B3001	2171B3002	2172B3002	3.8	3.3	3.6 (90)	3.0 (76)	7.0 (178)	3.0 (1.4)
1/2	2171B4011	2172B4011	2171B4012	2172B4012	4.0	3.5	3.6 (90)	3.0 (76)	7.0 (178)	3.0 (1.4)
1/2	2171B4001	2172B4001	2171B4002	2172B4002	7.7	6.5	4.6 (116)	3.0 (76)	7.7 (196)	3.3 (1.5)
3/4	2171B5001	2172B5001	2171B5002	2172B5002	9.0	7.3	4.6 (116)	3.0 (76)	7.7 (196)	3.3 (1.5)
1	2171B6011	2172B6011	2171B6012	2172B6012	9.0	7.9	4.6 (116)	3.0 (76)	7.7 (196)	3.3 (1.5)
1	2171B6001	2172B6001	2171B6002	2172B6002	24	21	6.6 (168)	4.1 (104)	10.5 (266)	7.5 (3.4)
1¼	2171B7001	2172B7001	2171B7002	2172B7002	29	20	6.6 (168)	4.1 (104)	10.5 (266)	7.5 (3.4)
1½	2171B8011	2172B8011	2171B8012	2172B8012	29	21	6.6 (168)	4.1 (104)	10.5 (266)	7.5 (3.4)

3/2 Valves

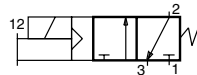
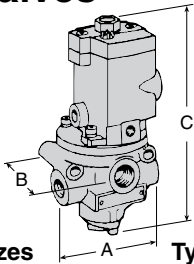

3/2 Normally Closed (NC)

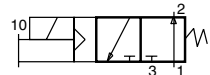

3/2 Normally Open (NO)

Port Sizes In-Out Exh.		Type H		Type O		Avg. C _v		Dimensions inches (mm)			Weight lb (kg)
NC	NO	NC	NO	NC	NO	NC	NO	A	B	C	
1/4	1/2	2173B2001	2174B2001	2173B2002	2174B2002	2.8	2.5	3.6 (90)	3.6 (90)	7.3 (186)	3.0 (1.4)
3/8	1/2	2173B3001	2174B3001	2173B3002	2174B3002	4.0	3.0	3.6 (90)	3.6 (90)	7.3 (186)	3.0 (1.4)
1/2	1/2	2173B4011	2174B4011	2173B4012	2174B4012	3.8	3.0	3.6 (90)	3.6 (90)	7.3 (186)	3.0 (1.4)
1/2	1	2173B4001	2174B4001	2173B4002	2174B4002	7.8	7.2	4.6 (116)	4.6 (117)	8.0 (203)	3.3 (1.5)
3/4	1	2173B5001	2174B5001	2173B5002	2174B5002	9.4	7.2	4.6 (116)	4.6 (117)	8.0 (203)	3.3 (1.5)
1	1	2173B6011	2174B6011	2173B6012	2174B6012	10	7.2	4.6 (116)	4.6 (117)	8.0 (203)	3.3 (1.5)
1	1½	2173B6001	2174B6001	2173B6002	2174B6002	29	21	6.6 (168)	6.6 (168)	10.5 (266)	7.5 (3.4)
1¼	1½	2173B7001	2174B7001	2173B7002	2174B7002	31	22	6.6 (168)	6.6 (168)	10.5 (266)	7.5 (3.4)
1½	1½	2173B8011	2174B8011	2173B8012	2174B8012	31	21	6.6 (168)	6.6 (168)	10.5 (266)	7.5 (3.4)

4/2 Valves

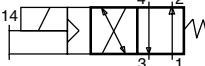
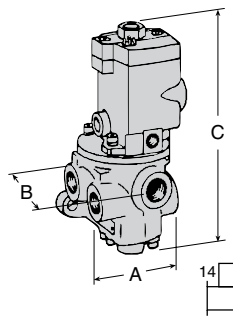

Port Sizes In-Out Exh.		Valve Model Number		Avg. C _v	Dimensions inches (mm)			Weight lb (kg)
A	B	C						
1/4	1/2	2176B2001	2176B2002	2.5	3.8 (97)	3.9 (99)	7.7 (196)	3.0 (1.4)
3/8	1/2	2176B3001	2176B3002	3.6	3.8 (97)	3.9 (99)	7.7 (196)	3.0 (1.4)
1/2	1/2	2176B4011	2176B4012	3.7	3.8 (97)	3.9 (99)	7.7 (196)	3.0 (1.4)
1/2	1	2176B4001	2176B4002	6.9	5.2 (132)	4.6 (104)	9.7 (246)	5.8 (2.6)
3/4	1	2176B5001	2176B5002	8.2	5.2 (132)	4.6 (104)	9.7 (246)	5.8 (2.6)
1	1	2176B6011	2176B6012	8.9	5.2 (132)	4.6 (104)	9.7 (246)	5.8 (2.6)
1	1½	2176B6001	2176B6002	23	8.2 (208)	6.5 (165)	11.1 (282)	12.0 (5.4)
1¼	1½	2176B7001	2176B7002	24	8.2 (208)	6.5 (165)	11.1 (282)	12.0 (5.4)
1½	1½	2176B8011	2176B8012	25	8.2 (208)	6.5 (165)	11.1 (282)	12.0 (5.4)

IMPORTANT NOTE Please read carefully and thoroughly all of the **CAUTIONS** on the inside back cover.

STANDARD SPECIFICATIONS: See page 7.

Series 21 Poppet Valves for Line Mounting

Single Pressure Controlled

2/2 Valves

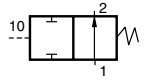
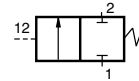
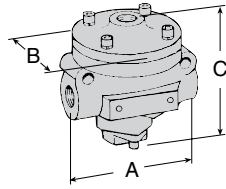

2/2 Normally Closed (NC)

2/2 Normally Open (NO)

Port Size	Valve Model Number				Avg. C _v		Dimensions inches (mm)			Weight lb (kg)
	Type H NC	Type H NO	Type O NC	Type O NO	NC	NO	A	B	C	
1/4	2151B2001	2152B2001	2151B2002	2152B2002	2.3	2.3	3.6 (90)	3.7 (94)	3.0 (94)	1.8 (0.8)
3/8	2151B3001	2152B3001	2151B3002	2152B3002	3.8	3.3	3.6 (90)	3.7 (94)	3.0 (94)	1.8 (0.8)
1/2	2151B4011	2152B4011	2151B4012	2152B4012	4.0	3.5	3.6 (90)	3.7 (94)	3.0 (94)	1.8 (0.8)
1/2	2151B4001	2152B4001	2151B4002	2152B4002	7.7	6.5	4.6 (116)	4.4 (112)	3.0 (94)	4.5 (2.0)
3/4	2151B5001	2152B5001	2151B5002	2152B5002	9.0	7.3	4.6 (116)	4.4 (112)	3.0 (94)	4.5 (2.0)
1	2151B6011	2152B6011	2151B6012	2152B6012	9.0	7.9	4.6 (116)	4.4 (112)	3.0 (94)	4.5 (2.0)
1	2151B6001	2152B6001	2151B6002	2152B6002	24	21	6.6 (168)	7.5 (190)	4.1 (104)	11.0 (5.0)
1¼	2151B7001	2152B7001	2151B7002	2152B7002	29	20	6.6 (168)	7.5 (190)	4.1 (104)	11.0 (5.0)
1½	2151B8011	2152B8011	2151B8012	2152B8012	29	21	6.6 (168)	7.5 (190)	4.1 (104)	11.0 (5.0)

3/2 Valves

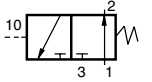
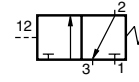
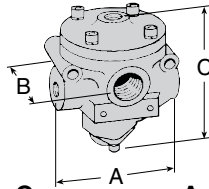

3/2 Normally Closed (NC)

3/2 Normally Open (NO)

Port Sizes In-Out Exh.		Valve Model Number				Avg. C _v		Dimensions inches (mm)			Weight lb (kg)
		Type H NC	Type H NO	Type O NC	Type O NO	NC	NO	A	B	C	
1/4	1/2	2153B2001	2154B2001	2153B2002	2154B2002	2.8	2.5	3.6 (90)	4.0 (101)	3.1 (79)	1.8 (0.8)
3/8	1/2	2153B3001	2154B3001	2153B3002	2154B3002	4.0	3.0	3.6 (90)	4.0 (101)	3.1 (79)	1.8 (0.8)
1/2	1/2	2153B4011	2154B4011	2153B4012	2154B4012	3.8	3.0	3.6 (90)	4.0 (101)	3.1 (79)	1.8 (0.8)
1/2	1	2153B4001	2154B4001	2153B4002	2154B4002	7.8	7.2	4.6 (116)	4.7 (120)	3.6 (91)	4.5 (2.0)
3/4	1	2153B5001	2154B5001	2153B5002	2154B5002	9.4	7.2	4.6 (116)	4.7 (120)	3.6 (91)	4.5 (2.0)
1	1	2153B6011	2154B6011	2153B6012	2154B6012	10	7.2	4.6 (116)	4.7 (120)	3.6 (91)	4.5 (2.0)
1	1½	2153B6001	2154B6001	2153B6002	2154B6002	29	21	6.6 (168)	7.5 (190)	4.8 (123)	11.0 (5.0)
1¼	1½	2153B7001	2154B7001	2153B7002	2154B7002	31	22	6.6 (168)	7.5 (190)	4.8 (123)	11.0 (5.0)
1½	1½	2153B8011	2154B8011	2153B8012	2154B8012	31	21	6.6 (168)	7.5 (190)	4.8 (123)	11.0 (5.0)

4/2 Valves

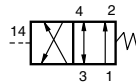
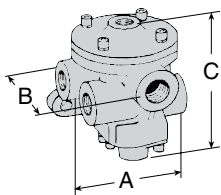

Port Sizes In-Out Exh.		Valve Model Number		Avg. C _v	Dimensions inches (mm)			Weight lb (kg)
		Number			A	B	C	
1/4	1/2	2156B2001	2156B2002	2.5	3.8 (97)	7.7 (196)	3.9 (99)	3.0 (1.4)
3/8	1/2	2156B3001	2156B3002	3.6	3.8 (97)	7.7 (196)	3.9 (99)	3.0 (1.4)
1/2	1/2	2156B4011	2156B4012	3.7	3.8 (97)	7.7 (196)	3.9 (99)	3.0 (1.4)
1/2	1	2156B4001	2156B4002	6.9	5.2 (132)	9.7 (246)	4.6 (104)	5.8 (2.6)
3/4	1	2156B5001	2156B5002	8.2	5.2 (132)	9.7 (246)	4.6 (104)	5.8 (2.6)
1	1	2156B6011	2156B6012	8.9	5.2 (132)	9.7 (246)	4.6 (104)	5.8 (2.6)
1	1½	2156B6001	2156B6002	23	8.2 (208)	11.1 (282)	6.5 (165)	12.0 (5.4)
1¼	1½	2156B7001	2156B7002	24	8.2 (208)	11.1 (282)	6.5 (165)	12.0 (5.4)
1½	1½	2156B8011	2156B8012	25	8.2 (208)	11.1 (282)	6.5 (165)	12.0 (5.4)

STANDARD SPECIFICATIONS: For valves on this page.

Ambient/Media Temperatures:

Type H: 0° to 300°F (-17° to 150°C).

Type O: -40° to 175°F (-40° to 80°C).

For temperatures below 40°F (4°C) air must be free of water vapor to prevent formation of ice.

Flow Media: Filtered air; 5 micron recommended.

Inlet Pressure: 30 to 150 psig (2 to 10 bar).

Pilot Pressure: Must be equal to or greater than inlet pressure.

Threads: Model numbers above specify NPT pressure port threads. For other threads, consult ROSS.

IMPORTANT NOTE Please read carefully and thoroughly all of the **CAUTIONS** on the inside back cover.

Series 21 Poppet Valves for Line Mounting

4/2 Valves – Double Direct Solenoid Controlled, Detented

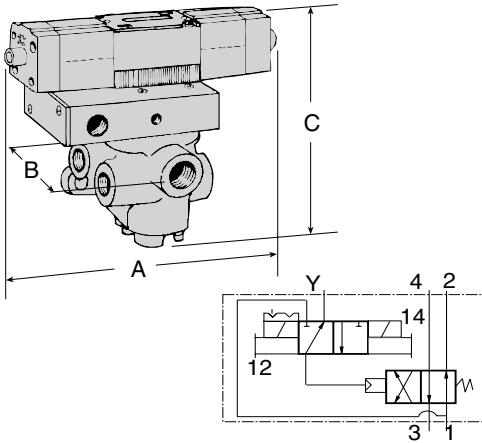

Port Sizes		Valve Model Number	Avg. C _v	Dimensions inches (mm)			Weight lb (kg)
In-Out	Exh.			A	B	C	
1/4	1/2	2176C2003	2.5	8.9 (226)	3.9 (97)	6.9 (176)	4.0 (1.8)
3/8	1/2	2176C3003	3.6	8.9 (226)	3.9 (97)	6.9 (176)	4.0 (1.8)
1/2	1/2	2176C4013	3.7	8.9 (226)	3.9 (97)	6.9 (176)	4.0 (1.8)
1/2	1	2176C4003	6.9	8.9 (226)	5.2 (132)	8.7 (221)	6.5 (3.0)
3/4	1	2176C5003	8.2	8.9 (226)	5.2 (132)	8.7 (221)	6.5 (3.0)
1	1	2176C6013	8.9	8.9 (226)	5.2 (132)	8.7 (221)	6.5 (3.0)
1	1½	2176C6003	23	8.9 (226)	8.2 (208)	10.4 (265)	13.3 (6.0)
1¼	1½	2176C7003	24	8.9 (226)	8.2 (208)	10.4 (265)	13.3 (6.0)
1½	1½	2176C8013	25	8.9 (226)	8.2 (208)	10.4 (265)	13.3 (6.0)

STANDARD SPECIFICATIONS: For valves listed above.

Solenoids: AC or DC power.

Standard Voltages: Consult ROSS.

Power Consumption: Each solenoid; 190 VA inrush, 40 VA holding on 50 or 60 Hz; 20 watts on DC.

Indicator Lights: In each solenoid housing.

Ambient Temperature: 40° to 120°F (4° to 50°C).

Media Temperature: 40° to 175°F (4° to 80°C).

For temperatures below 40°F (4°C) air must be free of water vapor to prevent formation of ice.

Flow Media: Filtered air; 5 micron recommended.

Inlet Pressure: 30 to 150 psig (2 to 10 bar).

Pilot Pressure: If external supply is used, pressure must be equal to or greater than inlet pressure.

Threads: Model numbers above specify NPT pressure port threads. For other threads, consult ROSS.

IMPORTANT NOTE

Please read carefully and thoroughly all of the **CAUTIONS** on the inside back cover.

What are Vacuum Service Valves?

Vacuum service valves are ideal for lifting, holding, vacuum packaging and moving anything from large objects to tiny particles. They also provide an effective means for leak testing. The vacuum source typically comes from either a vacuum pump or a venturi. In vacuum service applications, the pressure within the valve is reduced below atmospheric pressure. Consequently, atmospheric pressure actually pushes air into the valve, instead of the common belief that air is "sucked" in by the vacuum.

In normal valves, filters exist to clean compressed air, which is then pushed through the valve. In vacuum valves, there is no filter, and the air comes from the atmosphere and enters through the outlet, bringing with it atmospheric and nearby surface dust and dirt. Vacuum valves, in order to function consistently, must therefore be highly tolerant of the particles that freely flow into the valves.

To construct a vacuum service valve system, typically a 3/2 normally closed valve is used. The vacuum is on the inlet, while the exhaust remains open to atmosphere. Port 2 is the working port. However, if there is a need for the vacuum service valve to

function as normally open, simply connect the vacuum source to the exhaust and port 1 to atmosphere. Several variations of this construction are effective, including using 2/2 valves.

"Full Vacuum" Valves

Though there are fewer applications for full vacuum valves than regular vacuum valves, full vacuum valves are ideal for applications where compressed air is unavailable. Full vacuum valves use the difference in force between atmospheric pressure and the vacuum within the valve to actuate the valve. The full vacuum valve performs with atmospheric pressure in port 1 and 10 to 30 inches of Mercury vacuum in the valve body.

Remote Air or Solenoid-Piloted Vacuum Valves

Pilot vacuum valves provide a greater variety of applications, operating with a combination of vacuum and atmospheric pressure. The pilot must be supplied externally with a minimum of 30 psig. Vacuum valves can be used as either 3/2 normally closed or normally open valves, with vacuum supplied at either port 1 or port 3. Normally closed and normally open 2/2 versions are also available.

Anatomy of a Vacuum Service Valve

Special ROSS poppets are the toughest available, ideal for dirty vacuum applications. ROSS poppets also have large flow areas, which allow high flow.

ROSS vacuum valves have larger orifices, allowing greater flow and easing the transport of air even though there is a small differential between the vacuum within the valve and atmospheric pressure outside the valve.

ROSS poppet valves have specially designed seals for vacuum service applications that provide reliability and less leakage.



Pilot can be fed to port X-1 externally by compressed air. Internally, atmospheric pressure can be used as pilot for "full vacuum" version.

Typical applications place vacuum or atmosphere on port 1 (the inlet port in non-vacuum applications).

Port 2 is the working port.

Port 3 is open to atmosphere or vacuum, depending on application.

Why a ROSS Vacuum Valve?

In non-vacuum valves, maintaining consistent shift time is easier because clean air flows through the valve. However, the absence of a filter in vacuum service applications means that vacuum valve internals must be able to withstand high levels of dirt and continue shifting. That's why ROSS uses its famous poppet design in its vacuum valves.

ROSS Poppet Valves

ROSS poppets are known for their ability to withstand the harshest of environments and keep working consistently. What makes ROSS poppets shift so consistently and seal so effectively is its unbalanced design. The areas of the piston, the exhaust poppet and the inlet poppet are precisely designed to produce strong shifting forces in either direction as well as strong forces to keep the poppets sealed. In vacuum valve applications, a stronger spring is used to ensure the necessary shifting and sealing forces are maintained. Sometimes things get lodged between the poppet and the sealing surface. However, with the ROSS poppet valve design, anything caught inside is forced through the valve by the high velocity air flow within a few cycles. Flow velocity is dependent upon the area through which a volume of air is flowing. The smaller the area is, the greater the velocity will be. In ROSS poppet valves, the smallest flow-through area is across the poppet's seal and seat, momentarily, as the valve shifts. This design allows a high velocity, thereby blowing all dirt and foreign matter out of the seat area to provide a virtually leak-proof seal.

ROSS poppet valves are also effective because they achieve full flow quicker. In addition, ROSS poppet valves have large orifices, which are conducive to greater flow in low pressure differential situations, such as vacuum service.

For more information on vacuum service valves, contact ROSS Technical Services at (888) TEK-ROSS.

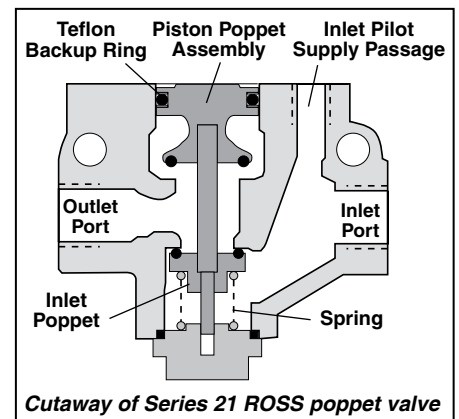

Solenoid Piloted "Full Vacuum" Valve Cross-Section

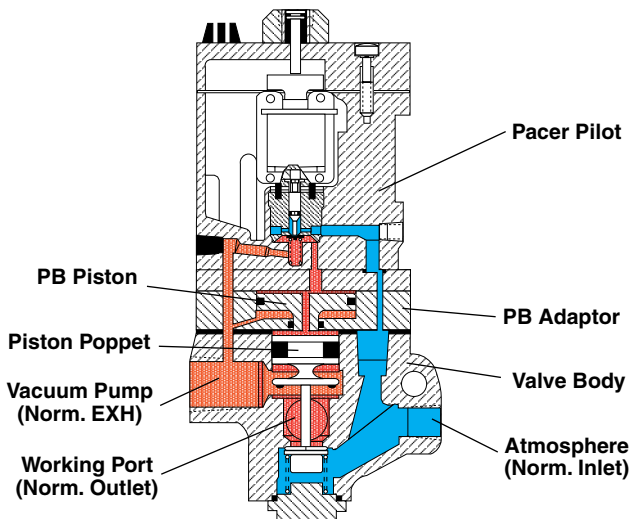

■ Vacuum Pump (Norm. Exhaust)

■ Atmosphere (Norm. Inlet)

Solenoid Piloted Valve with External Pilot Supply Cross-Section

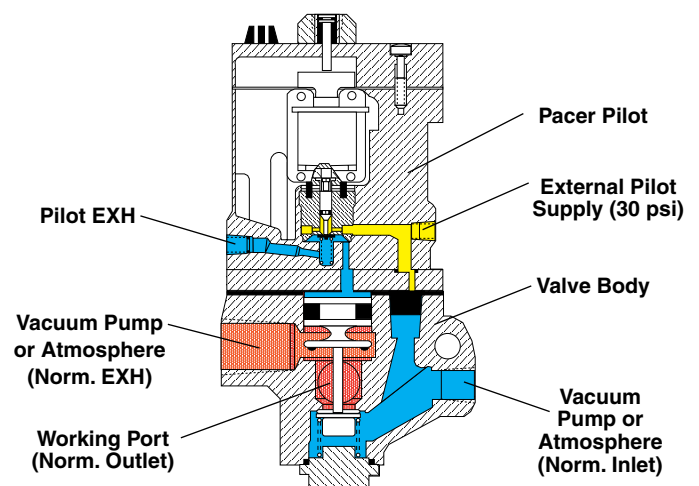

■ Pilot Pressure



Series 21 Solenoid Pilot Controlled Vacuum Valves

2/2 Valves

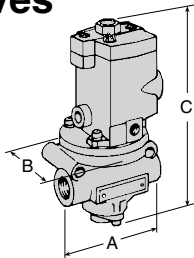

Normally Closed (NC)

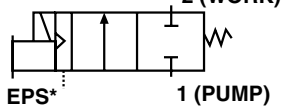

Normally Open (NO)

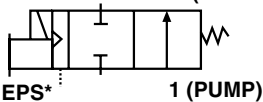

Piping 2/2 Normally Closed or Normally Open Valves

Pipe the unit into the system by connecting the vacuum source or pump to the normal air pressure inlet port (port 1). The normal outlet port is the work port (port 2).

Note: 2/2 vacuum valves provide only on/off control and do not have an exhaust function.

Port Size	Valve Model Number	Avg. Cv	Function	Dimensions inches (mm)			Weight lb (kg)
				A	B	C	
1/4	2171B2901	2.1	NC	3.6 (91)	3.0 (76)	7.0 (178)	3.0 (1.4)
1/4	2171B2908	2.1	NC	3.6 (91)	3.0 (76)	7.0 (178)	3.0 (1.4)
3/8	2171B3906	2.6	NC	3.6 (91)	3.0 (76)	7.0 (178)	3.0 (1.4)
3/4	2171B5905	7.8	NC	4.6 (117)	3.0 (76)	7.7 (196)	3.3 (1.5)
1	2171B6904	8.3	NC	4.6 (117)	3.0 (76)	7.7 (196)	3.3 (1.5)
1	2171B6915	20	NC	6.6 (168)	4.1 (104)	10.5 (266)	7.5 (3.4)
1 1/4	2171B7901	30	NC	6.6 (168)	4.1 (104)	10.5 (266)	7.5 (3.4)
1 1/2	2171B8906	31	NC	6.6 (168)	4.1 (104)	10.5 (266)	7.5 (3.4)
1 1/2	2172B8900	21	NO	6.6 (168)	4.1 (104)	10.5 (266)	7.5 (3.4)
2	2171A9900	57	NC	8.7 (219)	5.2 (131)	11.8 (300)	15.5 (6.9)
2	2172B9901	57	NO	8.7 (219)	5.2 (131)	11.8 (300)	15.5 (6.9)
2 1/2	2171B9901	64	NC	8.7 (219)	5.2 (131)	11.8 (300)	15.5 (6.9)

3/2 Valves

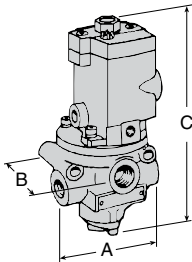

Normally Closed (NC)

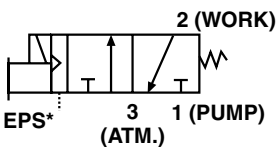

Normally Open (NO)

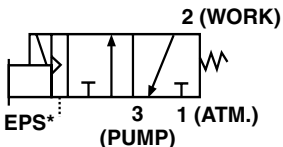

Piping 3/2 Normally Closed Valves

In this valve configuration, pipe the unit into the system by connecting the vacuum source or pump to the normal air pressure inlet port (port 1). The normal outlet port is the work port (port 2), and the normal air pressure exhaust port becomes the atmosphere port (port 3).

Piping 3/2 Normally Open Valves

To obtain a 3/2 normally open ROSS vacuum valve, simply pipe the 3/2 normally closed body slightly differently. Connect the vacuum source or pump to port 3, the normal exhaust. Leave port 1 open to atmosphere, and the normal outlet remains as the work port (port 2).

Port Size In-Out	Exh.	Valve Model Number	Avg. Cv In-Out	Out-Exh.	Function	Dimensions inches (mm)			Weight lb (kg)
						A	B	C	
1/4	1/2	2173B2900	2.4	3.4	NC	3.6 (90)	3.6 (90)	7.3 (186)	3.0 (1.4)
3/8	1/2	2173B3900	3.0	5.8	NC	3.6 (90)	3.6 (90)	7.3 (186)	3.0 (1.4)
3/8	1/2	2174B3900	3.0	5.8	NC	3.6 (90)	3.6 (90)	7.3 (186)	3.0 (1.4)
3/8	1/2	2173B3908	3.0	5.8	NO	3.6 (90)	3.6 (90)	7.3 (186)	3.0 (1.4)
1/2	1/2	2173B4901	3.0	5.2	NC	3.6 (90)	3.6 (90)	7.3 (186)	3.0 (1.4)
1/2	1	2173B4902	6.6	12	NC	4.6 (116)	4.6 (117)	8.0 (203)	3.3 (1.5)
1/2	1	2174A4912	6.5	7.0	NC	4.6 (116)	4.6 (117)	8.0 (203)	3.3 (1.5)
3/4	1	2173B5900	7.8	13	NC	4.6 (116)	4.6 (117)	8.0 (203)	3.3 (1.5)
3/4	1	2173B5903	7.5	7.5	NC	4.6 (116)	4.6 (117)	8.0 (203)	3.3 (1.5)
1	1	2173B6901	7.5	12	NC	4.6 (116)	4.6 (117)	8.0 (203)	3.3 (1.5)
1	1 1/2	2173B6902	24	40	NC	6.6 (168)	6.6 (168)	10.5 (266)	7.5 (3.4)
1	1 1/2	2174A6914	15	17	NO	6.6 (168)	6.6 (168)	10.5 (266)	7.5 (3.4)
1 1/4	1 1/2	2173B7901	29	39	NC	6.6 (168)	6.6 (168)	10.5 (266)	7.5 (3.4)
1 1/4	1 1/2	2173B7917	29	39	NO	6.6 (168)	6.6 (168)	10.5 (266)	7.5 (3.4)
1 1/2	1 1/2	2173A8911	30	38	NC	6.6 (168)	6.6 (168)	10.5 (266)	7.5 (3.4)
1 1/2	2 1/2	2173A8915	68	70	NC	8.7 (219)	6.4 (161)	12.4 (313)	16.5 (7.4)
2	2 1/2	2173A9905	70	70	NC	8.7 (219)	6.4 (161)	12.4 (313)	16.5 (7.4)
2 1/2	2 1/2	2173A9906	70	71	NC	8.7 (219)	6.4 (161)	12.4 (313)	16.5 (7.4)

STANDARD SPECIFICATIONS: For valves on this page.

Solenoids: Rated for continuous duty.

Standard voltages: 100-110 volts 50 Hz; 100-120 volts 60 Hz; 24, 110 volts DC.

Power Consumption: 87 VA inrush, 30 VA holding on 50 or 60 Hz; 14 Watts on DC.

Ambient Temperature: -40° to 120° F (-40° to 50° C). (For low temperature valves; High temperature valves also available.)

Media Temperature: -40° to 175° F (-40° to 80° C).

Flow Media: Vacuum and/or filtered-compressed air.

Pressure: Vacuum to 150 psig.

***External Pilot Pressure:** Equal or higher than inlet pressure, but not less than 30 psig.

IMPORTANT NOTE Please read carefully and thoroughly all of the **CAUTIONS** on the inside back cover.

Series 21 Pressure Controlled Vacuum Valves

2/2 Valves

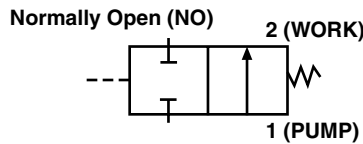
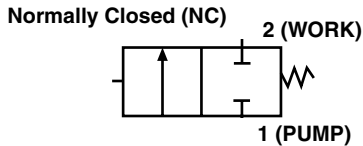
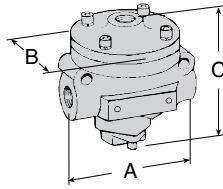

Piping 2/2 Normally Closed Valves

Pipe the unit into the system by connecting the vacuum source or pump to the normal air pressure inlet port (port 1). The normal outlet port is the work port (port 2).

Note: 2/2 vacuum valves provide only on/off control and do not have an exhaust function.

Port Size	Valve Model Number	Avg. Cv	Function	Dimensions inches (mm)			Weight lb (kg)
				A	B	C	
1/4	2151A2901	2.1	NC	3.6 (90)	3.7 (94)	3.0 (94)	1.8 (0.8)
1/2	2151B4904	6.9	NC	4.6 (116)	4.4 (112)	3.0 (94)	4.5 (2.0)
1/2	2151A4910	3.0	NC	3.6 (90)	3.7 (94)	3.0 (94)	1.8 (0.8)
3/4	2151A5913	7.8	NC	4.6 (116)	4.4 (112)	3.0 (94)	4.5 (2.0)
3/4	2151A5914	7.8	NC	4.6 (116)	4.4 (112)	3.0 (94)	4.5 (2.0)
3/4	2152A5901	7.0	NO	4.6 (116)	4.4 (112)	3.0 (94)	4.5 (2.0)
1	2151B6900	8.3	NC	4.6 (116)	4.4 (112)	3.0 (94)	4.5 (2.0)
1¼	2151A7909	30	NC	6.6 (168)	7.5 (190)	4.1 (104)	11.0 (5.0)
1½	2151B8900	31	NC	6.6 (168)	7.5 (190)	4.1 (104)	11.0 (5.0)
1½	2152B7900	23	NO	6.6 (168)	7.5 (190)	4.1 (104)	11.0 (5.0)

3/2 Valves

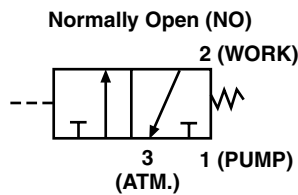
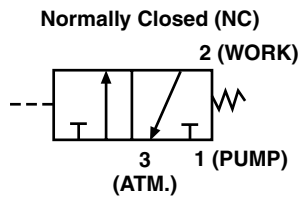
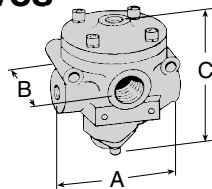

Piping 3/2 Normally Closed Valves

In this valve configuration, pipe the unit into the system by connecting the vacuum source or pump to the normal air pressure inlet port (port 1). The normal outlet port is the work port (port 2), and the normal air pressure exhaust port becomes the atmosphere port (port 3).

Piping 3/2 Normally Open Valves

To obtain a 3/2 normally open ROSS vacuum valve, simply pipe the 3/2 normally closed body slightly differently. Connect the vacuum source or pump to port 3, the normal exhaust. Leave port 1 open to atmosphere, and the normal outlet remains as the work port (port 2).

Port Size In-Out	Exh.	Valve Model Number	Avg. Cv		Function	Dimensions inches (mm)			Weight lb (kg)
			In-Out	Out-Exh.		A	B	C	
1/4	1/2	2153B2900	2.4	3.4	NC	3.6 (90)	4.0 (101)	3.1 (79)	1.8 (0.8)
1/2	1/2	2153B4903	3.0	5.2	NC	3.6 (90)	4.0 (101)	3.1 (79)	1.8 (0.8)
3/4	1	2153B5903	7.8	13	NC	4.6 (116)	4.4 (112)	3.0 (94)	4.5 (2.0)
1	1½	2153C6905	24	40	NC	6.6 (168)	7.5 (190)	4.8 (123)	11.0 (5.0)
1	1	2153A6906	7.4	12	NO	4.6 (116)	4.4 (112)	3.0 (94)	4.5 (2.0)
1¼	1½	2153A7906	29	39	NC	6.6 (168)	7.5 (190)	4.8 (123)	11.0 (5.0)
1½	1½	2153B8900	30	38	NC	6.6 (168)	7.5 (190)	4.8 (123)	11.0 (5.0)
2½	2½	2153A9902	70	71	NC	8.7 (219)	6.4 (161)	9.5 (241)	15.3 (6.9)
2	2½	2154A9900	58	61	NC	8.7 (219)	6.4 (161)	9.5 (241)	15.3 (6.9)

STANDARD SPECIFICATIONS: For valves on this page.

Media Temperature: -40° to 175° F (-40° to 80° C).

Flow Media: Vacuum and/or filtered-compressed air.

Pressure: Vacuum to 150 psig.

Signal Pressure: Equal or higher than inlet pressure, but not less than 30 psig.

STANDARD SPECIFICATIONS: For full vacuum valves, page 14.

Solenoids: Rated for continuous duty.

Standard voltages 100-110 volts 50 Hz; 100-120 volts 60 Hz; 24, 110 volts DC.

Power Consumption: 87 VA inrush, 30 VA holding on 50 or 60 Hz; 14 Watts on DC.

Ambient Temperature: -40° to 120° F (-40° to 50° C). (For low temperature valves; High temperature valves also available.)

Media Temperature: -40° to 175° F (-40° to 80° C).

Flow Media: Vacuum and/or filtered-compressed air.

Pressure: Vacuum to 150 psig.

***External Pilot Pressure:** Equal or higher than inlet pressure, but not less than 30 psig.

IMPORTANT NOTE: Please read carefully and thoroughly all of the **CAUTIONS** on the inside back cover.



Series 21 Solenoid Pilot Controlled Full Vacuum Valves

Full Vacuum — 3-Way Normally Closed

This valve functions as a **normally open** valve. Pipe the unit into the system by connecting the vacuum source or pump to port 3, the normal exhaust. Leave port 1 open to atmosphere, and the normal outlet remains as the work port (port 2).

Normally Closed (NC)

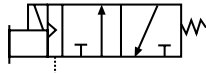

Normally Open (NO)



Full Vacuum — 3-Way Normally Open

This valve functions as a **normally closed** valve. Pipe the unit into the system by connecting the vacuum source or pump to port 3, the normal exhaust. Leave port 1 open to atmosphere, and the normal outlet remains as the work port (port 2).

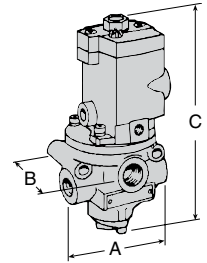

Port Size In-Out	Valve Model Exh. Number	Avg. Cv In-Out	Avg. Cv Out-Exh.	Function	Dimensions inches (mm)			Weight lb (kg)	
					A	B	C		
1/2	1/2	2173B4914	3.0	5.2	NC	3.6 (90)	3.6 (90)	7.3 (186)	3.0 (1.4)
1/2	1/2	2174B4900	2.9	2.8	NC	3.6 (90)	3.6 (90)	7.3 (186)	3.0 (1.4)
1 1/4	1 1/2	2173B7904	29	39	NC	6.6 (168)	6.6 (168)	10.5 (266)	7.5 (3.4)
1 1/4	1 1/2	2174A7903	21	23	NO	6.6 (168)	6.6 (168)	10.5 (266)	7.5 (3.4)

Series 16 Compact Poppet Valves, Line or Manifold Mounting

With Direct Acting Solenoid Control

Series 16 valves are direct acting solenoid valves of small size and high reliability. They are suitable for use either with or without air line lubrication. Valves are available for 1/8 and 1/4 port sizes in three valve types: 3/2 normally open or closed and 4/2. Models are available for either inline mounting or manifold mounting.

3/2 Valves – Single Direct Solenoid

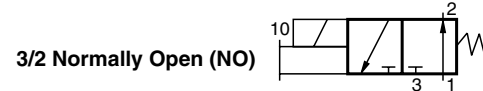
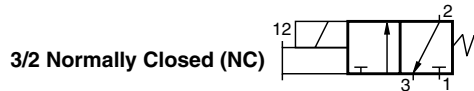

Port Size	Valve Type	Valve Model Numbers		Avg. Cv	Dimensions inches (mm)			Weight lb (kg)
		NC	NO		A	B	C	
For Line Mounting								
1/8	Y	1613B1020	1614B1020	0.3	2.7 (69)	3.8 (95)	3.0 (77)	1.4 (0.6)
1/4	Y	1613B2020	1614B2020	0.3	2.7 (69)	3.8 (95)	3.0 (77)	1.4 (0.6)
For Manifold Mounting								
1/4	Z	1613C2322*	1614B2322*	0.3	2.7 (69)	6.6 (168)	4.2 (107)	1.4 (0.6)

*Also order manifold **256B91** (not included with this valve).

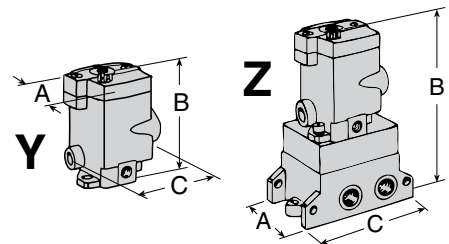

4/2 Valves – Single Solenoid Pilot Controlled

Port Size	Valve Type	Valve Model Number	Avg. Cv	Dimensions inches (mm)			Weight lb (kg)
				A	B	C	
For Line Mounting							
1/4	Y	1616C2020	0.4	2.7 (69)	4.8 (121)	6.6 (168)	2.4 (1.1)
For Manifold Mounting							
1/4	Z	1616C2322*	0.4	2.7 (69)	6.6 (168)	4.2 (107)	2.4 (1.1)

*Also order manifold **257B91** (not included with this valve).

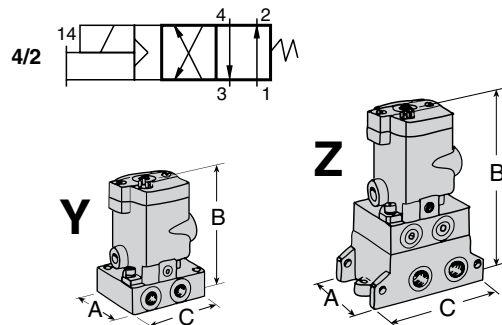

IMPORTANT NOTE: Please read carefully and thoroughly all of the **CAUTIONS** on the inside back cover.

Series 16 Compact Poppet Valves, Line or Manifold Mounting

STANDARD SPECIFICATIONS: For valves on this page.

Solenoids: AC or DC power.

Standard Voltages: Consult ROSS.

Power Consumption: 87 VA inrush, 30 VA holding on 50 or 60 Hz; 14 watts on DC.

Ambient Temperature: 40° to 120°F (4° to 50°F).

Media Temperature: 40° to 175°F (4° to 80°C).

Inlet Pressure: 3/2 Valves: 5 to 150 psig (0.3 to 10 bar).
4/2 Valves: 30 to 150 psig (2 to 10 bar).

Flow Media: Filtered air; 5 micron recommended.

Manual Override: Flush flexible manual override (non-locking), standard.

Port Treads: NPT standard. For BSPP threads, add a “D” prefix to the model number; for J threads, add a “J” prefix to the model number.

Options:

Indicator Light: Order kit number **862K87** and specify the voltage of the solenoid.

Manual Override: Metal button; see Manual Override Kits.

Cautions

PRE-INSTALLATION or SERVICE

1. Before servicing a valve or other pneumatic component, be sure that all sources of energy are turned off, the entire pneumatic system is shut off and exhausted, and all power sources are locked-out (ref: OSHA 1910.147, EN 1037).
2. All ROSS products, including service kits and parts, should be installed and/or serviced only by persons having training and experience with pneumatic equipment. Because any installation can be tampered with or need servicing after installation, persons responsible for the safety of others or the care of equipment must check every installation on a regular basis and perform all necessary maintenance.
3. All applicable instructions should be read and complied with before using any fluid power system in order to prevent harm to persons or equipment. In addition, overhauled or serviced valves must be functionally tested prior to installation and use.
4. Each ROSS product should be used within its specification limits. In addition, use only ROSS parts to repair ROSS products. Failure to follow these directions can adversely affect the performance of the product or result in the potential for human injury.

FILTRATION and LUBRICATION

5. Dirt, scale, moisture, etc. are present in virtually every air system. Although some valves are more tolerant of these contaminants than others, best performance will be realized if a filter is installed to clean the air supply, thus preventing contaminants from interfering with the proper performance of the equipment. ROSS recommends a filter with a 5-micron rating for normal applications.
6. All standard ROSS filters and lubricators with polycarbonate plastic bowls are designed for compressed air applications only. Do *not* fail to use the metal bowl guard, where provided, to minimize danger from high pressure fragmentation in the event of bowl failure. Do not expose these products to certain fluids, such as alcohol or liquefied petroleum gas, as they can cause bowls to rupture, creating a combustible condition, hazardous leakage, and the potential for human injury. Immediately replace a crazed, cracked, or deteriorated bowl. When bowl gets dirty, replace it or wipe it with a clean dry cloth.

7. Only use lubricants which are compatible with materials used in the valves and other components in the system. Normally, compatible lubricants are petroleum base oils with oxidation inhibitors, an aniline point between 180°F (82°C) and 220°F (104°C), and an ISO 32, or lighter, viscosity. Avoid oils with phosphate type additives which can harm polyurethane components, potentially leading to valve failure and/or human injury. If you have questions regarding whether a lubricant used on your system is compatible with ROSS products, please contact ROSS.

AVOID INTAKE/EXHAUST RESTRICTION

8. Do not restrict the air flow in the supply line. To do so could reduce the pressure of the supply air below the minimum requirements for the valve and thereby cause erratic action.
9. Do not restrict a valve's exhaust port as this can adversely affect its operation. Exhaust silencers must be resistant to clogging and have flow capacities at least as great as the exhaust capacities of the valves. Contamination of the silencer can result in reduced flow and increased back pressure.

ROSS expressly disclaims all warranties and responsibility for any unsatisfactory performance or injuries caused by the use of the wrong type, wrong size, or inadequately maintained silencer installed with a ROSS product.

POWER PRESSES

10. Mechanical power presses and other potentially hazardous machinery using a pneumatically controlled clutch and brake mechanism must use a press control double valve with a monitoring device. A double valve without a self-contained monitoring device should be used only in conjunction with a control system which assures monitoring of the valve. All double valve installations involving hazardous applications should incorporate a monitoring system which inhibits further operation of the valve and machine in the event of a failure within the valve mechanism.

ENERGY ISOLATION/EMERGENCY STOP

11. Per specifications and regulations, ROSS **L-O-X®** and manual **L-O-X®** with **EEZ-ON®** operation products are defined as energy isolation devices, NOT AS EMERGENCY STOP DEVICES.

WARRANTY

Products manufactured by ROSS are warranted to be free of defects in material and workmanship for a period of one year from the date of purchase. ROSS' obligation under this warranty is limited to repair or replacement of the product or refund of the purchase price paid solely at the discretion of ROSS and provided such product is returned to ROSS freight prepaid and upon examination by ROSS is found to be defective. This warranty shall be void in the event that product has been subject to misuse, misapplication, improper maintenance, modification or tampering. THE WARRANTY EXPRESSED ABOVE IS IN LIEU OF AND EXCLUSIVE OF ALL OTHER WARRANTIES AND ROSS EXPRESSLY DISCLAIMS ALL OTHER WARRANTIES EITHER EXPRESSED OR IMPLIED WITH RESPECT TO MERCHANTABILITY OR FITNESS FOR A PARTICULAR PURPOSE. ROSS MAKES NO WARRANTY WITH RESPECT TO ITS PRODUCTS MEETING THE PROVISIONS OF ANY GOVERNMENTAL OCCUPATIONAL SAFETY AND/OR HEALTH LAWS OR REGULATIONS. IN NO EVENT SHALL ROSS BE LIABLE TO PURCHASER, USER, THEIR EMPLOYEES OR OTHERS FOR INCIDENTAL OR CONSEQUENTIAL DAMAGES WHICH MAY RESULT FROM A BREACH OF THE WARRANTY DESCRIBED ABOVE OR THE USE OR MISUSE OF THE PRODUCTS. NO STATEMENT OF ANY REPRESENTATIVE OR EMPLOYEE OF ROSS SHALL EXTEND THE LIABILITY OF ROSS AS SET FORTH HEREIN.





GLOBAL Reach with a LOCAL Touchsm

ROSS CONTROLS

Troy, MI., U.S.A.

Telephone: + 1-248-764-1800

Fax: + 1-248-764-1850

In the United States:

Customer Service: 1-800-GET ROSS
(438-7677)

Technical Service: 1-888-TEK-ROSS
(835-7677)

www.rosscontrols.com

ROSS EUROPA GmbH

Langen, Germany

Telephone: + 49-6103-7597-0

Fax: + 49-6103-74694

Email: info@rosseuropa.com

www.rosseuropa.com

ROSS ASIA K.K.

Kanagawa, Japan

Telephone: + 81-427-78-7251

Fax: + 81-427-78-7256

www.rossasia.co.jp

ROSS UK Ltd.

Birmingham, United Kingdom

Telephone: + 44-121-559-4900

Fax: + 44-121-559-5309

Email: sales@rossuk.co.uk

ROSS CONTROLS INDIA Pvt. Ltd.

Chennai, India

Telephone: + 91-44-2624-9040

Fax: + 91-44-2625-8730

Email: rossindia@airtelbroadband.in

ROSS SOUTH AMERICA Ltda.

São Paulo, Brazil CEP 09725-020

Telephone: + 55-11-4335-2200

Fax: + 55-11-4335-3888

Email: vendas@ross-sulamerica.com.br

DIMAFLUID s.a.s.

Saint Ouen, France

Telephone: + 33-01-49-45-65-65

Fax: + 33-01-49-45-65-30

Email: dimafluid@dimafluid.com

www.dimafluid.com

ROSS CONTROLS (CHINA) Ltd.

Shanghai, China

Telephone: + 86-21-6915-7951

Fax: + 86-21-6915-7960

Email: alvinzhurong@vip.163.com

Your local ROSS distributor is:

There are ROSS Distributors Throughout the World

To meet your requirements across the globe, ROSS distributors are located throughout the world. Through ROSS or its distributors, guidance is available for the selection of ROSS products, both for those using pneumatic components for the first time and those designing complex pneumatic systems.

This catalog presents an overview of the extensive ROSS product line. Other literature is available for engineering, maintenance, and service requirements. If you need products or specifications not shown here, please contact ROSS or your ROSS distributor. They will be happy to assist you in selecting the best product for your application.