



Parker Hannifin Corporation's Veriflo Division presents CGA Connections. CGA's are used to connect Semiconductor/High Purity-Specialty gases in process applications.



features

- ▶ 100% visual inspection of critical surfaces.
- ▶ Cleaned and packaged in a certified environment.

Nuts

- ▶ Stainless Steel Silver Plated.

Nipples

- ▶ "VeriClean", Veriflo's High Purity type 316L Stainless Steel.
- ▶ Non-rotating design.
- ▶ Heat code traceability.
- ▶ Electropolished, 9 Ra internal surfaces.

Gaskets

- ▶ Available in PCTFE, Aluminum, and Nickel.
- ▶ Retainer ring included.
- ▶ Gaskets individually packaged in lots of 25 pieces.

Outlet Adapters

- ▶ 316L Stainless Steel.
- ▶ Non-rotating design.
- ▶ Electropolished internal surfaces.

Cylinder Valve Outlet Caps

- ▶ Gas tight design.
- ▶ Nickel gasket, ring, and chain included.

materials of construction

Wetted

Nuts 303 Stainless Steel

Nipples "VeriClean", Veriflo's high purity type 316L Stainless Steel, Nickel, Hastelloy®C-22

Outlet Adapters 316L Stainless Steel, Nickel, Hastelloy®C-22

Cylinder Valve Outlet Caps 316L Stainless Steel, Nickel, Hastelloy®C-22

Gaskets Nickel 200, PCTFE, Aluminum

CGA DISS Series

Dimensional Drawing

54 Series Assembly

Includes: Nut, Nipple and Nickel Gasket

CGA/DISS Number	End Connection	H Overall Length	F Hex Flat
632 thru 642	1/4" Tube Weld	2.50	1-1/4"
	1/4" Faceseal Male	3.00	
	1/4" NPT Male	3.00	
712 thru 728	1/4" Tube Weld	2.50	1-3/8"
	1/4" Faceseal Male	3.00	
	1/4" NPT Male	3.00	

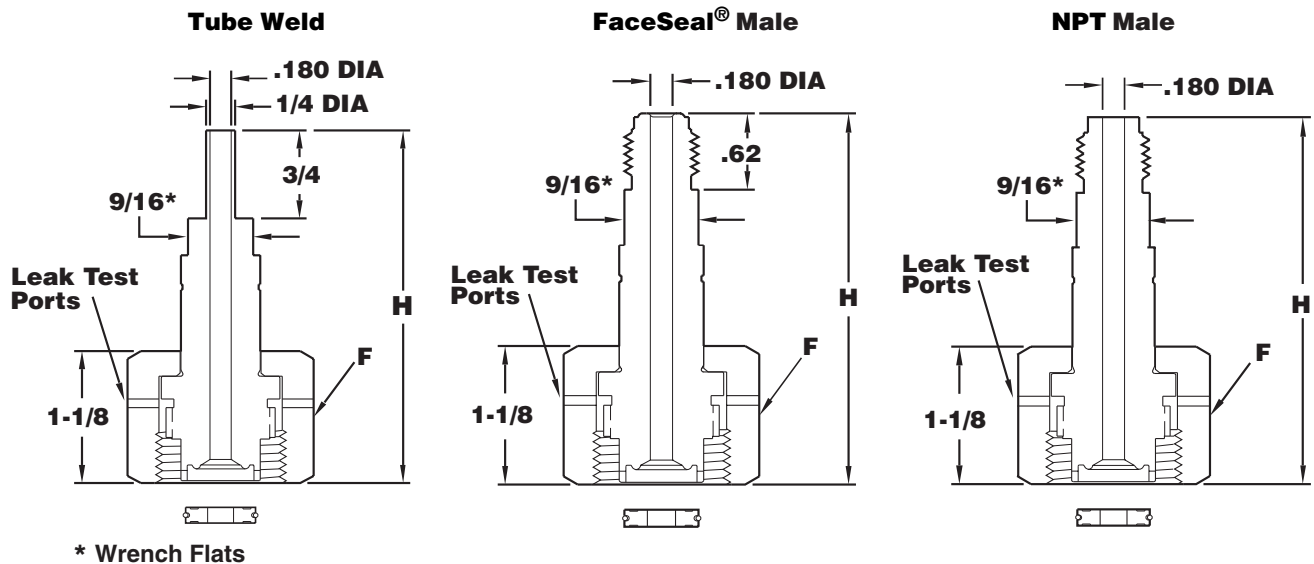

58 Series Assembly

Includes: Nut, Nipple Tube Weld, Nickel Gasket, and Blank Plug

CGA/DISS Number	End Connection	H Overall Length	F1 Hex Flat	F2 Hex Flat
632 thru 642	1/4" Tube Weld	3.40	1-1/4"	1-1/8"
712 thru 728			1-3/8"	1-1/4"

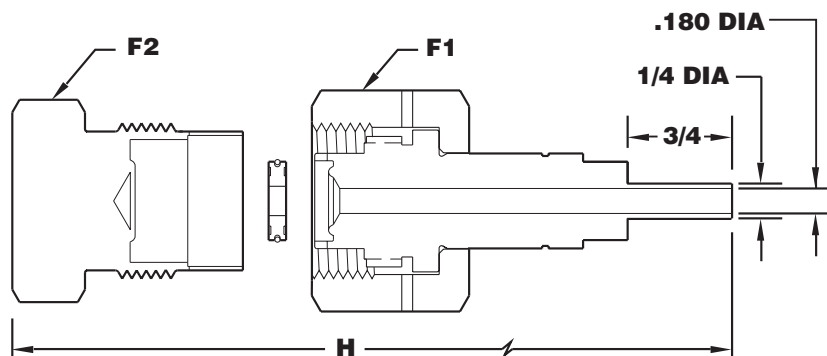

CGA DISS Series

UHP CGA Cap 632-642 AND 712-728

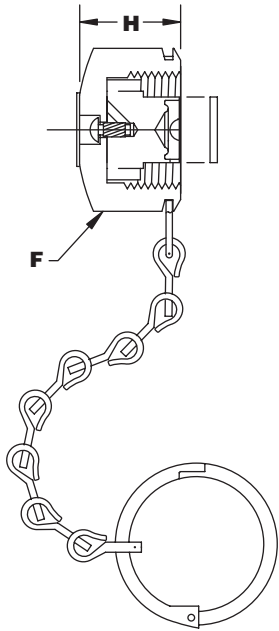

CGA Number	Part Number	Material	F Hex Flat	S Hex Flat	H Length	Gas-Tight*
632	53-63GTC-2NR	Stainless Steel with Nickel gasket	1-1/4"	-	.98"	Yes
634	53-63GTC-2NR	Stainless Steel with Nickel gasket	1-1/4"	-	.98"	Yes
636	53-63GTC-2NR	Stainless Steel with Nickel gasket	1-1/4"	-	.98"	Yes
638	53-63GTC-2NR	Stainless Steel with Nickel gasket	1-1/4"	-	.98"	Yes
640	53-63GTC-2NR	Stainless Steel with Nickel gasket	1-1/4"	-	.98"	Yes
642	53-63GTC-2NR	Stainless Steel with Nickel gasket	1-1/4"	-	.98"	Yes
712	53-71GTC-2NR	Stainless Steel with Nickel gasket	1-3/8"	-	.98"	Yes
714	53-71GTC-2NR	Stainless Steel with Nickel gasket	1-3/8"	-	.98"	Yes
716	53-71GTC-2NR	Stainless Steel with Nickel gasket	1-3/8"	-	.98"	Yes
718	53-71GTC-2NR	Stainless Steel with Nickel gasket	1-3/8"	-	.98"	Yes
720	53-71GTC-2NR	Stainless Steel with Nickel gasket	1-3/8"	-	.98"	Yes
722	53-71GTC-2NR	Stainless Steel with Nickel gasket	1-3/8"	-	.98"	Yes
724	53-71GTC-2NR	Stainless Steel with Nickel gasket	1-3/8"	-	.98"	Yes
726	53-71GTC-2NR	Stainless Steel with Nickel gasket	1-3/8"	-	.98"	Yes
728	53-71GTC-2NR	Stainless Steel with Nickel gasket	1-3/8"	-	.98"	Yes

CGA DISS Series

Dimensional Drawing

50 Series SpectraTite™ Gaskets

Gaskets for CGA 632-728

Material	A	H	E
Nickel 200	.56	.105	.21
PCTFE	.56	.125	.21
Aluminum	.56	.105	.21

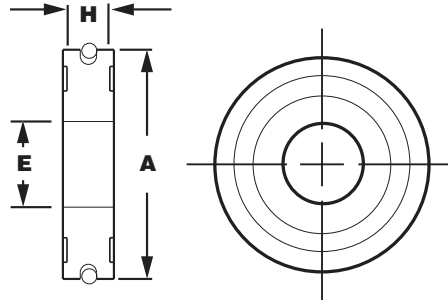

(Nickel Gasket Shown)

57 Series Outlet Adaptors and Blank Plugs

CGA/DISS Number	End Connection	H Overall Length	F Hex Flat
632 thru 642	Blank Plug	1.53	1-1/8"
	1/4" Faceseal Male	2.00	
	1/4" NPT Female	1.85	
712 thru 718	Blank Plug	1.53	1-1/4"
	1/4" Faceseal Male	2.00	
	1/4" NPT Female	1.85	
720 thru 728	Blank Plug	1.53	1-1/4"
	1/4" Faceseal Male	2.00	
	1/4" NPT Female	1.85	

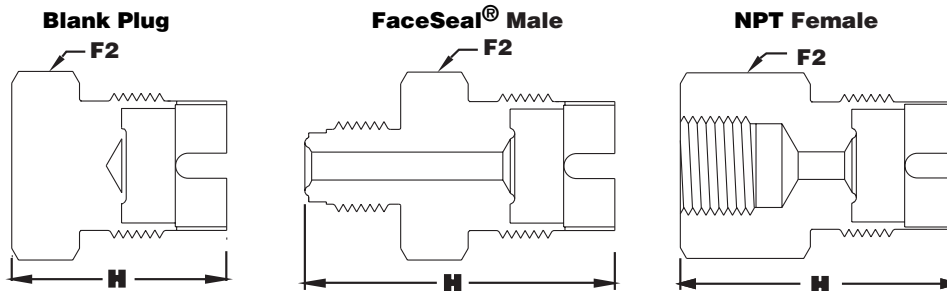

Torque Wrenches

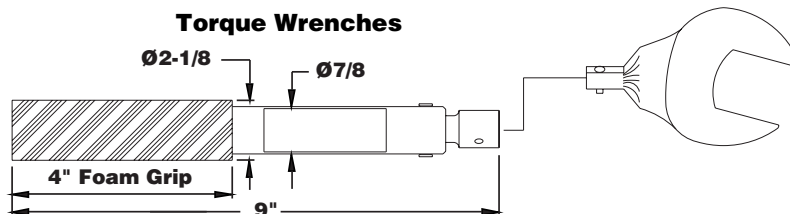

Part Number	Factory Set Torque	For Use With	CGA 632-642 Hex Flat	CGA 712-728 Hex Flat	CGA 326,346, 350 Hex Flat
77-DISS-TW	35 ft-lbs	Nickel Gasket	1-1/4	1-3/8	-
77-DISS-TW-K	12 ft-lbs	PCTFE Gasket	1-1/4	1-3/8	-

Torque wrenches are specifically designed for use with the Compressed Gas Association's 632-642 and 712-728 series of connections. Torque is factory set to the CGA recommendations. Calibration service is also available and is recommended every six months or 4,000 cycles, whichever comes first.

CGA DISS Series

Ordering Information

BASIC SERIES

- 53 = See Page 3
- 54* = UHP CGA Connection Assembly
- 58** = Complete Pigtail Connections

CGA#

- 632
- 634
- 636
- 638
- 640
- 642
- 712
- 714
- 716
- 718
- 720
- 722
- 724
- 726
- 728

GASKET MATERIAL (54 Series Only)

- N = Nickel
- K = PCTFE
- A = Aluminum

MATERIAL

- 2 = 316L Vericlean Stainless Steel
- 5 = Monel
- 16 = Hastelloy
- 31 = Nickel

CONNECTION TYPE

- TW = Tube Weld
- VM = Faceseal Male (54 Series Only)
- M = NPT Male (54 Series Only)

END CONNECTION

- 4 = 1/4"
- Other Sizes Available Upon Request

- * Includes Nut, Nipple and Nickel Gasket.
- ** Includes Nut, Nipple, Nickel Gasket, and Adapter.

Hastelloy C-22® is a registered trademark of Haynes International, Inc.

CGA/DISS Number	End Connection	Part Number Nipple	Part Number Gasket Nut	Part Number Gasket (Ni)	Part Number Gasket PCTFE	Part Number Gasket Aluminum
632 thru 642	1/4" Tube Weld	56-***-4TW2	55-62-3	50-63-Ni	50-63-K	50-63-AL
	1/4" Faceseal Male	56-***-4VM2				
	1/4" NPT Male	56-***-4M2				
712 thru 728	1/4" Tube Weld	56-***-4TW2	55-71-3	50-63-Ni	50-63-K	50-63-AL
	1/4" Faceseal Male	56-***-4VM2				
	1/4" NPT Male	56-***-4M2				

*** CGA Number, see Assembly Ordering Information for specific number.

CGA/DISS Number	End Connection	Part Number Adapter
632 thru 642	Blank Plug	57-63MXX-2
	1/4" Faceseal Male	57-***M4VM-2
	1/4" NPT Female	57-***M4F-2
712 thru 718	Blank Plug	57-70MXX-2
	1/4" Faceseal Male	57-***M4VM-2
	1/4" NPT Female	57-***M4F-2
720 thru 728	Blank Plug	57-72MXX-2
	1/4" Faceseal Male	57-***M4VM-2
	1/4" NPT Female	57-***M4F-2

*** CGA Number, see Assembly Ordering Information for specific number.

CGA DISS Series

GAS CONNECTION ASSIGNMENT TABLE **

For pressures up to 4704 psig (320 bar) dependent on CGA, DIN, JIS, ISO organization specifications.

GAS	UHP CGA	CGA	DIN	JIS
Ammonia	720	705	DIN 6	22-R
Argon	718	580	DIN 6	22-R or 23-R
Arsenic Pentafluoride	642	-	-	-
Arsine	632	350	-	22-L
Boron Trichloride	634	660	DIN 8	-
Boron Trifluoride	642	330	DIN 8	22-L
Carbon Dioxide	716	320	DIN 6	-
Carbon Monoxide	724	350	DIN 5	22-L
Chlorine	728	-	DIN 8	26-R
Diborane	632	350	-	22-L
Dichlorosilane	636	678*	DIN 5	-
Diethylzinc	726	510*	-	-
Diethyltelluride	726	-	-	-
Dimethylzinc	726	-	-	-
Disilane	632	-	-	-
Germane	632	350 or 660	-	-
Halocarbon 11	716	660	-	-
Halocarbon 115	716	660	DIN 6	-
Halocarbon 12	716	660	DIN 6	-
Halocarbon 13	716	660	DIN 6	-
Halocarbon 14	716	320 or 580	DIN 6	-
Halocarbon 23	716	660	DIN 6	-
Halocarbons 116	716	660	-	-
Helium	718	580	DIN 6	22-R OR 23-R
Hydrogen	724	350	DIN 1	22-L
Hydrogen Bromide	634	330	DIN 8	26-R
Hydrogen Chloride	634	330	DIN 8	26-R
Hydrogen Fluoride	638	660 or 670	-	26-R
Hydrogen Sulfide	722	330	DIN 5	-
Krypton	718	580	DIN 6	22-R OR 23-R
Neon	718	580	DIN 6	22-R OR 23-R
Nitrogen	718	580	DIN 10	22-R OR 23-R
Nitrogen Trifluoride	640	330 or 670	DIN 8	-
Nitrous Oxide	712	326	DIN 8	-
Oxygen	714	540	DIN 9	22-R OR 23-R
Perfluoropropane	716	660	-	-
Phosphine	632	350 or 660	DIN 1	-
Phosphorus Pentafluoride	642	330 or 660	-	-
Silane	632	350	-	-
Silicon Tetrachloride	636	-	-	-
Silicon Tetrafluoride	642	330	-	22-L
Sulphur Hexafluoride	716	590	DIN 6	26-R
Trichlorosilane	636	-	-	-
Triethylaluminum	726	510*	-	-
Tungsten Hexafluoride	638	670	DIN 8	-
Xenon	718	580	DIN 6	22-R

* Consult CGA, DIN, JIS, ISO organization specifications for pressure limits.

**Information in this table was obtained from reliable sources. It shall be used for reference only. Actual gas assignments are subject to periodic change and the user must verify all information in this table at time of use. For verification, contact the Compressed Gas Association Offices.

CGA DISS Series

Appendix

GAS CONNECTION ASSIGNMENT TABLE SOURCES

The Gas Connection Assignment table is presented for information purposes only and informs the reader of outlet specifications that are enumerated in other selected international standards.

A list of these standards is included below. Every effort has been made to include the most recent copy of each standard, as of March 1994. The reader is encouraged to determine if a subsequent issue of a particular standard has been issued since the publication of this document.

The user is further cautioned that:

- The pressure ranges in each of the listed standards for the connections listed are not necessarily equivalent.
- The connections listed for a particular gas in these different standards are not identical nor are they interchangeable.
- These tables are not part of the standard, but as stated above, are provided for information purposes only.

STANDARDS

- Compressed Gas Association Publication V-1 (2002 Edition)
- Deutscher Institute für Normung 477 Part 1 (May 1990 Edition)
- Japanese Industrial Standard B8244 (Translated) (1989 Edition)
- Japanese Industrial Standard B8246 (Translated) (1989 Edition)
- International Organization for Standardization ISO/DIS 407 (1983 Edition)
- Deutscher Institute für Normung 477 Part 8 (1990 Edition)

CGA DISS Series

The Compressed Gas Association (CGA) has established and maintains a standardized set of valve outlet and inlet connections to help minimize the possibility of hazardous misconnections of incompatible gases. The need for standardization was recognized by both industry and the military during the World War I era when the multiplicity of connections then in use created unsafe conditions.

Over the past two decades, the growth of the semiconductor and other high technology industries, combined with the development of new gases, further accelerated the need for classification and assignment of gases to specific CGA connections.

Veriflo Division, Parker Hannifin Corporation, a member of the Association, is committed to manufacturing and supplying ultra high integrity CGA or DISS connections including nipples, nuts, gaskets, adapters, caps and plugs. The technical expertise involved in the research, design, development, and manufacture of each component ensures the integrity of the connection. An ultra high integrity connection is referred to as a "DISS" connection. "DISS" is the acronym for "Diameter Index Safety System".

WARNING

FAILURE, IMPROPER SELECTION OR IMPROPER USE OF THE PRODUCTS AND/OR SYSTEMS DESCRIBED HEREIN OR RELATED ITEMS CAN CAUSE DEATH, PERSONAL INJURY AND PROPERTY DAMAGE.

This document and other information from Parker Hannifin Corporation, its subsidiaries and authorized distributors provide product and/or system options for further investigation by users having technical expertise. It is important that you analyze all aspects of your application and review the information concerning the product or system in the current product catalog. Due to the variety of operating conditions and applications for these products or systems, the user, through its own analysis and testing is solely responsible for making the final selection of the products and systems and assuring that all performance, safety and warning requirements of the application are met.

The products described herein, including without limitation, product features, specifications, designs, availability and pricing, are subject to change by Parker Hannifin Corporation and its subsidiaries at any time without notice

Offer of Sale

The items described in this document are hereby offered for the sale by Parker Hannifin Corporation, its subsidiaries or its authorized distributors. This offer and its acceptance are governed by the provisions stated in the "offer of Sale".