



# BRD<sup>®</sup>

Bellofram Rolling Diaphragm  
DESIGN MANUAL



**Bellofram Corporation**  
ORIGINATOR OF THE ROLLING DIAPHRAGM



## TABLE OF CONTENTS

The Rolling Diaphragm Concept	2
<i>Conquering Friction</i>	
<i>Rolling Diaphragm Operating Features &amp; Benefits</i>	
Theory of Rolling Diaphragm Operation	3
Typical Diaphragm Application	3
Rolling Diaphragm Nomenclature	4
Designing with Bellofram Rolling Diaphragms - Introduction	6
Class 4 Diaphragms	7
<i>Description</i>	
<i>Dimensions and Tolerances</i>	
<i>Standard Sizes</i>	
Class 4C Diaphragms	13
<i>Description</i>	
<i>Dimensions and Tolerances</i>	
<i>Standard Sizes</i>	
Class 3 Diaphragms	15
<i>Description</i>	
<i>Dimensions and Tolerances</i>	
<i>Standard Sizes</i>	
Class 3C Diaphragms	18
<i>Description</i>	
<i>Dimensions and Tolerances</i>	
<i>Standard Sizes</i>	
Class 1A Diaphragms	19
<i>Description</i>	
<i>Dimensions and Tolerances</i>	
<i>Standard Sizes</i>	
Class 1B Diaphragms	20
<i>Description</i>	
<i>Dimensions and Tolerances</i>	
<i>Standard Sizes</i>	
Involuted Diaphragms	21
<i>Description</i>	
<i>Dimensions</i>	
Elastomer Data	22
<i>Elastomer Properties</i>	
<i>Chemical Resistance of Diaphragm Elastomers</i>	
Fabric Performance Data	23
<i>Fabric Strength</i>	
<i>Working Pressures</i>	
<i>Degradation Factors at Elevated Temperatures</i>	
<i>Involuted Diaphragm Fabric Data</i>	
Hardware Design	24
<i>General - Cylinder Design - Hardware Finish - Curved Lip Retainer Plates</i>	
<i>Class 4 and 4C</i>	
<i>Class 3 and 3C</i>	
<i>Class 1A</i>	
<i>Class 1B</i>	
Application Data	28
<i>Diaphragm Trim and Perforation</i>	
<i>Forming the Convolution During Assembly</i>	
<i>Alternative Methods of Attaching Diaphragm to Piston</i>	
<i>Effects of Pressure Reversal - Surface Coatings - Piston Eccentricity - Shaft Torque</i>	
<i>Designing for Increased Diaphragm Life</i>	
Application Data Design Parameter Sheet	31
For Savings in Cost and Delivery	32
<i>Diaphragm Part Number Designation</i>	
Special Products	33



## THE ROLLING DIAPHRAGM

In 1950 it was becoming increasingly apparent that designers of machines, instruments and automotive vehicles could not continue to live with the serious problems of friction and leakage which had long been associated with O-rings, chevron seals, cup packings, metal bellows and other conventional seals.

At that time, Bellofram initiated what proved to be a five-year program of intensive research and development, to produce a frictionless and leak-proof rolling seal that would handle pressures, temperatures and stroke lengths over an extremely wide range. At the end of the five years, the company had produced a complete line of rolling seal diaphragms for a broad variety of industrial needs.

The immediate, wide-spread acceptance of this successful new principle of sealing resulted in rapid company growth, and in 1957 Bellofram erected facilities in Burlington, Massachusetts. In 1989, Bellofram moved into a new, modern facility in Newell, WV, designed, constructed and fully integrated specifically for the high-volume, high-precision manufacture of elastomer products.

Clean, well-kept and well-organized, the building itself has been carefully laid out to ensure the smooth, efficient flow of materials and work in process. Its complement of tools, automatic machinery and specialized processing and production equipment is one of the most extensive in the industry.

With significant resources of technical personnel and skilled production workers, the Newell facility is well suited to the economical manufacture of highly engineered elastomeric products. Prototypes, pilot quantities and full production runs can be accommodated quickly and with minimum set-up.

Precision, a keynote of the operation, is evident at every step of the manufacturing process, from mold design and machining and elastomer preparation and processing to final test and inspection.

Bellofram precision starts with the design and fabrication of molds and tools which are manufactured in-house with the aid of sophisticated CAD and CNC equipment. Tooling reflects the in-depth, on-sight expertise in elastomer product design.

Molds are built and maintained to exact tolerances to ensure continuing SPC capability, on time delivery and customer satisfaction.

The performance of the rolling diaphragm depends, in large part, on the preparation of materials. Raw materials are accepted after close scrutiny and absolute conformity to tight specifications.

Elastomers are compounded with extreme care, then coded to ensure complete batch traceability.

Reinforcing fabrics are woven or knitted to specifications developed exclusively by Bellofram.

Meticulous preforming practices help to ensure a permanent, high strength bond between elastomer and fabric.

The molding facility in Newell, one of the largest in the industry, features more than 150 advanced presses designed to produce diaphragms that will perform perfectly for years.

Molded diaphragms are finished trimmed to customer requirements in high precision tooling mounted in modern automatic, hydraulic presses.

From creation, through manufacturing processes and packaging for shipment, Bellofram Rolling Diaphragms are subject to numerous inspections and tests. These tests are as accurate and reliable as modern technology can provide.

A completely equipped laboratory provides an acceptability check of incoming materials, ensures that elastomers and fabrics delivered to the press will yield technically consistent product, and maintains records of physical tests performed on finish molded diaphragms.

First article, in-process and final inspections are provided by the Bellofram Quality Assurance Department. Quality engineers monitor processes and perform life cycle tests upon request. Material certifications are available.

Bellofram offers SPC (Statistical Process Control) documentation on key dimensions for high volume applications to guarantee the quality of the final product. Bellofram earned ISO 9002 certification in 1992.

Our applications engineers are prepared to help you design the most efficient and cost effective Bellofram Rolling Diaphragms for your specific needs.

### IMPORTANT NOTICE

Our recommendations, if any, for the use of this product are based on tests believed to be reliable. The greatest care is exercised in the selection of our raw materials and in our manufacturing operations. However since the use of this product is beyond the control of the manufacturer, no guarantee or warranty, expressed or implied is made as to such use or effects incidental to such use, handling or possession or the results to be obtained, whether in accordance with the directions or claimed so to be. The manufacturer expressly disclaims responsibility therefore. Furthermore, nothing contained herein shall be construed as a recommendation to use any product in conflict with existing laws and/or patents covering any material or use.

Copyright © 1998 by Bellofram Corporation. This design manual cannot be reproduced in whole or in part without written permission from Bellofram Corporation.



**THE ROLLING DIAPHRAGM CONCEPT**

**CONQUERING FRICTION**

The Bellofram Rolling Diaphragm\* (BRD) is a tough, flexible seal with a unique configuration that permits relatively long piston strokes while completely eliminating sliding friction.

Formed in the shape of a truncated cone, or top hat, the diaphragm is turned in on itself when installed so that, during the stroke, it rolls and unrolls alternately on piston skirt and cylinder wall. The rolling action is smooth and effortless, completely eliminating sliding contact and breakaway friction.

With the outer flange clamped to the cylinder and the center fastened to the piston head, the BRD forms a perfect barrier, preventing blow-by leakage and pressure loss.

Depending on the materials and geometry selected, BRD can function effectively with applied pressures of 3000 pounds. Operating temperatures may range from -120°F to +600°F. Diaphragms are available which are highly resistant to oil, ozone, acids, alkalies, steam and other corrosive fluids.

**ROLLING DIAPHRAGM CONSTRUCTION**

BRD diaphragm material is essentially a layer of specially woven fabric, impregnated with a thin layer of elastomer. Total thickness is usually 0.015 to 0.045 inches. The fabric, which lends high tensile strength to the diaphragm, is designed to permit free circumferential elongation (allowing free rolling action) while preventing axial distortion. This eliminates stretching or ballooning during the stroke.

The flex life of the rolling diaphragm depends on operating pressures, amount of axial and circumferential stress applied during the stroke, and the materials which form it. In general, a properly installed BRD will provide a life of millions of cycles.

**ROLLING DIAPHRAGM APPLICATIONS**

Because of its unique properties, the BRD is widely used in controls and actuators requiring high sensitivity to small pressure changes and excellent accuracy and reproducibility. They are also used where no leakage can be tolerated, and where more liberal machining tolerances can significantly reduce hardware costs. Typical products using the BRD include: pressure regulators, linear actuators, demand valves, dashpots, measuring instruments, gauge protectors, air relays, etc.

\*Patent numbers 3,137,215 and 3,373,236

**ROLLING DIAPHRAGM OPERATING FEATURES & BENEFITS**

- Friction-Free  
*Sliding friction is completely eliminated*
- No Breakaway Friction  
*No resistance to start-up motion even after long periods in one position*
- No Spring Rate  
*No change in resistance to applied pressure throughout stroke*
- High Sensitivity  
*Extremely responsive to small pressure variations*
- Long Life  
*Smooth, non-abrading operation and tough construction ensure long operating life*
- Leak-Proof  
*No blow-by leakage*
- Versatile  
*Can be furnished for a broad-range of pressures, temperatures and fluids*
- Low Hysteresis  
*Provides consistent positioning with identical applied pressures, regardless of stroke direction*

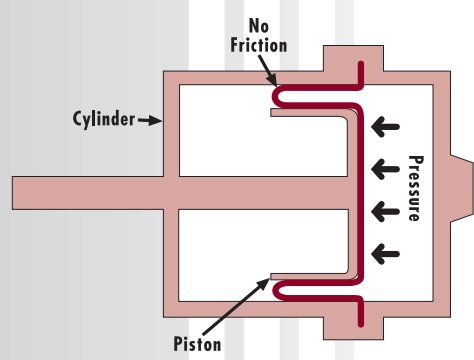

Fig. 1: Rolling Diaphragm installed in cylinder

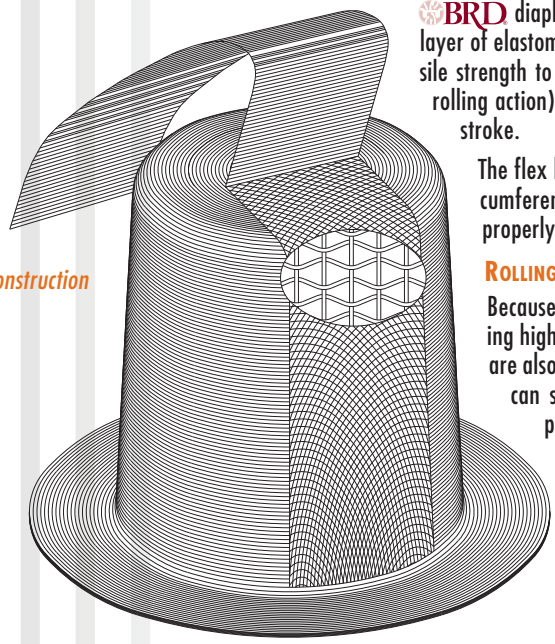



Fig. 2: BRD Construction



### THEORY OF ROLLING DIAPHRAGM OPERATION

Bellofram Rolling Diaphragms are, in effect, pressure vessels having a variable volume and flexible moving side-walls. As in any other pressure vessel, their strength should be considered with respect to safety factors. Generally, they are designed with a large safety factor. This means the maximum safe working pressure will be a fraction of the pressure that could cause failure of the sidewall.

The accompanying illustration, Fig. 3, illustrates the pressure reaction of the . Here it can be seen that almost the entire pressure load is supported by the piston head. Only a small amount of the liquid or gas pressure is supported by the narrow convolution of the rolling diaphragm. Referring to Fig. 4., particularly, to that portion of the convolution in immediate contact with the cylinder and piston walls, it will be noted that the lines of unit pressure (acting in horizontal plane because they must be normal to the surface) force the diaphragm against the piston and cylinder sidewalls.

The lines of pressure acting on that portion of the diaphragm not in immediate contact with cylinder and piston walls (semi-circular segment of the convolution) are shown in Fig. 4. Each line of unit pressure acts in a direction normal to the semi-circular segment; hence all of the pressure lines can be replaced by their horizontal and vertical components. The sum of the vertical components is the total force acting on the semi-circular segment.

Actual stress analysis and selection of fabrics will be made by the Bellofram Application Engineering Department.

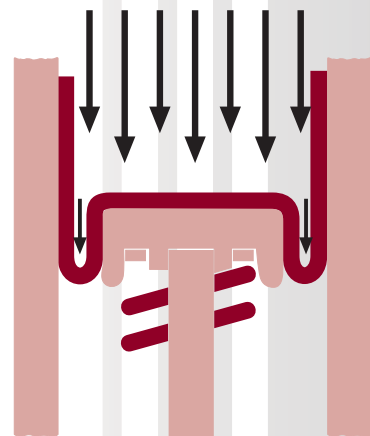

Fig. 3

### DIAPHRAGM APPLICATIONS

The applications for  are found in every industry—automotive, agricultural, aerospace, medical, etc.

For proper Bellofram Rolling Diaphragm selection the Design Parameter Sheet is an indispensable tool. The design format provides all the necessary data for correct diaphragm design (see page 31).

Below is a partial list of applications:

- |  |  |
|--|--|
| <i>Process Control Valves</i>                | <i>Dancer Roll Actuators</i>             |
| <i>Air Pressure Regulators</i>               | <i>Industrial Brakes</i>                 |
| <i>Displacement Pumps</i>                    | <i>Expansion Chambers</i>                |
| <i>Liquid Dispensing Equipment</i>           | <i>Automatic Transmission Modulators</i> |
| <i>Valve Positioners</i>                     | <i>LP Gas Regulators</i>                 |
| <i>Automatic Choke Controls</i>              | <i>Timing Chain Tensioners</i>           |
| <i>Distributor Vacuum Advance Mechanisms</i> | <i>Pressure Switches</i>                 |
| <i>Irrigation Valves</i>                     | <i>Flow Control Valves</i>               |
| <i>Aircraft Environmental Controls</i>       | <i>Fire Sprinkler Alarms</i>             |
| <i>Belt Guide Actuators</i>                  | <i>Domestic Hot Water Regulators</i>     |
| <i>Automotive Locking Hubs</i>               | <i>Waste Gate Actuators</i>              |
| <i>Anti-Scald Devices</i>                    | <i>Fuel Pressure Controls</i>            |
| <i>Truck Brake Actuators</i>                 | <i>Vacuum Switches</i>                   |
| <i>Automotive Emission Controls</i>          | <i>Pressure Transducers</i>              |
| <i>Geothermal Pumps</i>                      | <i>Vacuum Regulators</i>                 |
| <i>Automatic Door Locks</i>                  | <i>Gage Isolators</i>                    |
| <i>Tank Truck Valves</i>                     | <i>Linear Actuators</i>                  |
| <i>Water Conditioning Valves</i>             | <i>Flush Valves</i>                      |
| <i>Pneumatic Relays</i>                      |  |

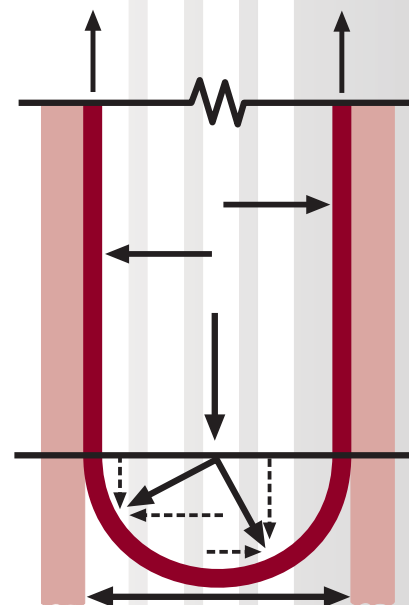

Fig. 4



**ROLLING DIAPHRAGM NOMENCLATURE**

**“C” STYLE**

Preconvoluted diaphragm. Convolution is molded into “as installed” shape.

**CLASS**

A description of the molded configuration of the diaphragm and its flange.

**CONVOLUTION WIDTH C**

The radial clearance between the cylinder wall and piston wall of the hardware.

**CYLINDER BORE, D<sub>C</sub>**

Inside diameter of the cylinder into which the diaphragm will fit and function.

Note: This pertains to the hardware not the diaphragm.

**EFFECTIVE AREA, A<sub>E</sub>**

The effective pressure area of the system is defined by a diameter halfway between the hardware cylinder bore and piston diameters. It may be calculated by this formula:

$$A_E = .7854 \left( D_C - \frac{D_C - D_P}{2} \right)^2$$

Effective area does not change regardless of stroke position as long as the diaphragm remains in a 180° convolution.

**FLANGE**

Outer portion of the diaphragm retained, supported or clamped by the hardware.

**FLANGE CORNER RADIUS**

The blend radius between the sidewall and flange of the diaphragm.

**FLASH**

A fine line of material projecting from the edge of a diaphragm, formed by the parting line or other openings in the mold. It usually cannot be completely removed by trimming.

**HEAD**

Area of the diaphragm retained against the piston head.

**HEAD CORNER RADIUS**

The blend radius between the head and sidewall of the diaphragm.

**HEIGHT, H AND K**

Height of the diaphragm (H for “Top hat” or K for “C” style), is measured from bottom of flange to top of head (or convolution in “C” style). Height is measured from top of bead to top of head on Class 1A & 1B type of diaphragms (does not include height of bead).

**HEIGHT / STROKE LIMITS**

Height of diaphragm necessary to obtain a particular stroke. Formulas for determining this relationship are as follows:

For “Top Hat” Style Diaphragms Required Height:

$$H = S_M + 2R_p + 1.56C + W_f + Z$$

For “C” Style Diaphragms:

$$\text{Required Height: } K = 1/2 (S_M + C + 2R_p + 2W_f)$$

K – Height of “C” style BRD

S<sub>M</sub> – Maximum half stroke; S<sub>A</sub> up stroke; S<sub>B</sub> down stroke

Z – Safety factor constant

W<sub>f</sub> – Flange Thickness

H – Height of “Top Hat” style BRD

C – Convolution width

R<sub>p</sub> – Piston corner radius

R<sub>L</sub> – Cylinder corner radius

Cylinder bore	.33/.99	1.00/2.50	2.51/4.00	4.01/8.00
Z	.060	.100	.120	.140

**IDENTIFICATION**

Diaphragms are identified by a Bellofram ABC (Approximate Bellofram Code) part number.

example:

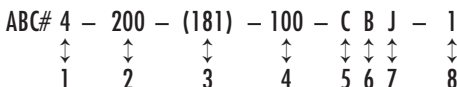

1. Class of diaphragm
2. Cylinder bore (D<sub>C</sub>) = 2.000 dia.
3. Piston diameter (D<sub>p</sub>) = 1.812” dia. (used only when non-standard DP is required and always placed in parentheses)
4. Height, H (or K in “C” style) 1.00”
5. Bellofram’s designation for sidewall thickness (May also be a group of numbers)
6. Bellofram’s designation for fabric. (May also be group of numbers or if no fabric put a dash in parentheses)
7. Bellofram’s designation for elastomer. (May also be group of numbers)
8. -1 Designates that the diaphragm has special trim

**PISTON DIAMETER D<sub>p</sub>**

Diameter of the piston as measured diametrically across the piston head.

Note: this pertains to the hardware, not the diaphragm.

**PRESSURE DROP ACROSS DIAPHRAGM**

The **BRD** is designed to have the higher pressure acting on the elastomer side, the pressure on the fabric side should always be less under all conditions of operations.

**SIDEWALL THICKNESS, W<sub>SW</sub>**

Thickness of the sidewall; that portion of the diaphragm between the head and flange, or between the head and beaded area.

**STROKE**

- Neutral Plane Position (Fig. 5) – The stroke capability of a diaphragm is usually calculated or specified using “neutral position” (neutral plane) as a basis. It is defined as that point in the stroke where the piston head is in the same plane as the clamping flange of the cylinder.
- Half Stroke – Many designs involve stroking the piston and diaphragm in only one direction from the neutral plane. “Half-stroke” is the term used to designate the stroke capability of the diaphragm under this condition. The half-stroke is designated as S<sub>B</sub> if it strokes below neutral plane. (Fig. 6) If a bonnet is used, the piston and diaphragm are allowed to stroke above the neutral plane, also. This portion of the diaphragm stroke capability is designated as S<sub>A</sub> stroke above neutral plane. (Fig. 7)
- Full Stroke (Total Stroke) – The full stroke capability of the diaphragm is the sum of the half strokes (S<sub>A</sub> + S<sub>B</sub> = S<sub>T</sub>). S<sub>T</sub> designates the total stroke.

**TOP HAT**

Diaphragm molded in familiar “hat” shape that is formed into a rolling convolution when assembled into the hardware

**TRIM**

Head and flange contour and perforations, made according to customer’s design requirements or Bellofram standards (if not specified by customer).



**STROKE OF DIAPHRAGM IN CYLINDER**

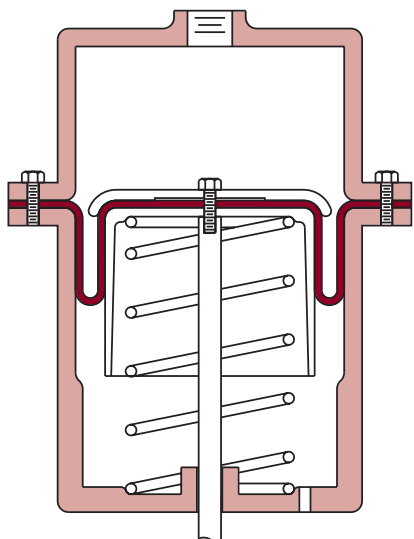

Fig. 5: Neutral Plane Position

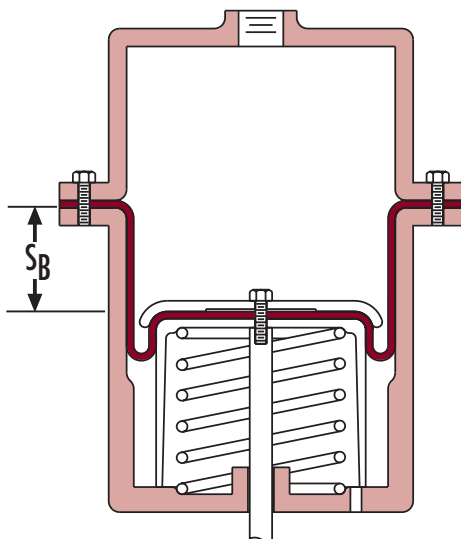

Fig. 6: Down-Stroke Position

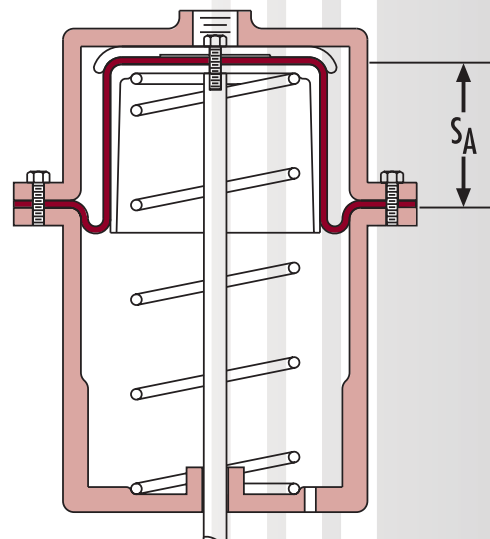

Fig. 7: Up-Stroke Position

Fig. 8. Dimensional Relationship of Diaphragm / Cylinder

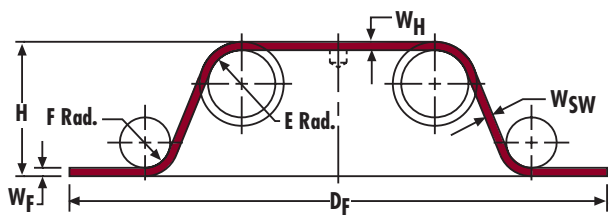
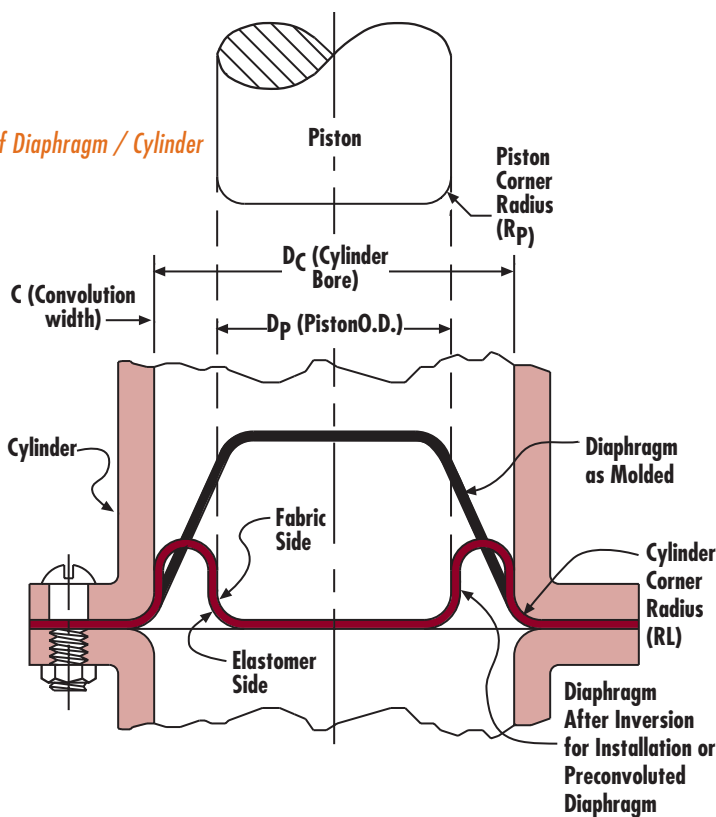

Fig. 9: Top Hat Diaphragm

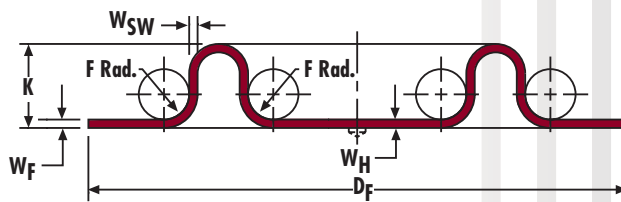

Fig. 10: Preconvoluted Diaphragm

E	- HEAD CORNER RADIUS	D <sub>F</sub>	- FLANGE DIAMETER
F	- FLANGE CORNER RADIUS	W <sub>F</sub>	- FLANGE THICKNESS
H	- HEIGHT OF TOP HAT INCLUDING FLANGE THICKNESS	W <sub>H</sub>	- HEAD THICKNESS
K	- HEIGHT OF PRECONVOLUTION INCLUDING FLANGE THICKNESS	W <sub>SW</sub>	- SIDEWALL THICKNESS

**DESIGNING WITH ROLLING DIAPHRAGMS – INTRODUCTION**

The purpose of this Design Manual is to guide you in the selection of the proper Bellofram Rolling Diaphragm (BRD) for your application as well as to describe the applicable hardware design criteria.

To efficiently select a diaphragm and to design hardware, it is advisable that decisions be made in logical sequence. The information in this Manual, presented in detail on the following pages and briefly below, is in such sequence. The first step is to complete the Design Parameter Sheet\*. This will provide basic information that will aid you in making selections from the following:

\*The "Design Parameter Sheet" is on page 31 in this manual. Extra copies can be obtained by writing Bellofram. info@bellofram.com

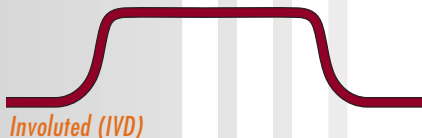

**1. DIAPHRAGM SELECTION (TYPES)**

The configurations listed below can be designed for double-coat construction.

"Top Hat" – For long stroke applications. It is formed into a rolling convolution at assembly.

"C" Style – Is molded into a preconvoluted configuration for limited stroke applications.

Involute (IVD) – Combines advantages of "Top Hat" and "C" styles for special applications requiring minimum hardware envelope.

**2. DIAPHRAGM CLASS**

Class of diaphragm applies to the flange and / or bead design of the diaphragm which determines the hardware clamping methods. The classes are as follows:

Class 4 – A flat gasket type flange for high pressure sealing and economical hardware design.

Class 3 – A "D" shaped bead is molded on a small flange extension for positive sealing at lower pressures and ease of assembly.

Class 1A – An "O" ring type bead is molded tangent to the diaphragm outside diameter to allow for reduction of the cylinder diameter.

Class 1B – A bead is molded on the inside diameter of the diaphragm wall to provide for minimum cylinder diameter.

**3. STROKE CAPABILITY**

For "top-hat" BRD the height is calculated for a 1/2-stroke capability that will insure a 180° convolution from one end of stroke to the other.

The "C" style BRD is calculated to have a convolution height (K) sufficient to provide the desired 1/2-stroke.

The Involute diaphragm provides a 1/2-stroke capability equal to its height.

**4. ELASTOMER SELECTION**

The elastomer is selected to be compatible with the liquids or gases in the application across the temperature range of the application.

**5. FABRIC SELECTION**

The type of fabric determines the working pressure capability of the diaphragm and is selected based on strength factor, convolution width and temperature.

**6. HARDWARE DESIGN**

The elements of hardware design are as follows:

**Diaphragm Flange Retention** – A method of retaining the diaphragm flange (of whichever class is chosen) in hardware must be selected.

**Cylinder Design** – The inside diameter of the cylinder should be designed to fit the diaphragm diameter designated  $D_C$  (cylinder bore diameter). Cylinder length must be long enough to provide the half stroke in the  $S_B$  direction along with sufficient length to accommodate the piston skirt.

**Bonnet Design** – The bonnet diameter should allow sufficient clearance for the piston and diaphragm sidewall thickness. The length will allow for the half stroke in the  $S_A$  direction.

**Piston Design** – The piston diameter should be designed to match the piston diameter for which the diaphragm is designed. The length should be long enough to support the rolling convolution from one end of stroke to the other.

**Retainer Design** – The diaphragm should be retained to the piston head with either a flat or curved lip retainer or an adhesive.



**CLASS 4 DIAPHRAGMS**

**DESCRIPTION**

The Class 4 diaphragm is the most common design and offers economical hardware design. It was developed for installation in mechanisms which have flat mating surfaces between the cylinder and its cap or bonnet. In these cases the flange of the diaphragm serves primarily as a gasket to prevent leakage at these parting surfaces. The flanges can be perforated during manufacture to accommodate through bolts. Similarly, the periphery of the flange can be trimmed to match almost any configuration of the mating parts. Refer to pg. 28 for trim and perforation considerations (fig. 37).

Class 4 diaphragms can be used to seal high pressures since the fabric overlay is in intimate contact with the clamped metal surfaces, thus providing secure retention across a large sealing surface.

The forces which act upon the flange joint are complex and variable. In general, flange pressure loading is determined by: internal pressures, operating temperature and environmental liquid and gases. The actual flange loading pressure required to provide adequate sealing effects has generally been found to be on the order of 1000 psi across the sealing area of the flange. If this pressure is seriously exceeded, excess elastomer flow may result, causing eventual damage to the rolling diaphragm.

The clamping flange surface should be flat over its contacting area and should not distort under applied bolt loads. Improved flange retention can be achieved by using a rough machined hardware finish at the flange clamping area, provided no sharp edges are created which would tend to cut the elastomeric surface. A series of concentric "V" grooves spaced approximately 1/32" apart at a depth of 0.006" is suggested for retention under extremely high pressure, or with extra wide convolution applications where flange pullout forces are large.

In Class 4 designs, the convolution is formed by inverting the top head corner radius during installation. In order to keep the piston corner radius from re-inverting during operation, a curved lip retainer plate is recommended.



*Diaphragms are shown in the "as molded" configurations. The diaphragm must be inverted prior to installation.*

**DIMENSIONS AND TOLERANCES**

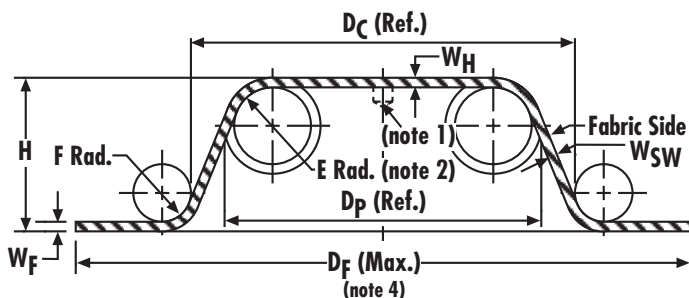

D <sub>C</sub>	.25 – .99	1.00 – 2.50	2.51 – 4.00	4.01 – 8.00	8.01 and up
H	As required to yield design stroke (See standard size tables & NOTE 3)				
D <sub>C</sub>	Tolerances on D <sub>C</sub> and D <sub>p</sub> are ± .010" per inch of diameter but the tolerance will be no less than ± .010" or greater than ± .060"				
D <sub>p</sub>					
W <sub>H</sub> & W <sub>F</sub>	.020 ± .005	.020 ± .005	.030 ± .005	.035 ± .005	.045 ± .007
W <sub>SW</sub>	.015 ± .003 (Code "B")	.017 ± .003 (Code "C")	.024 ± .004 (Code "D")	.035 ± .005 (Code "F")	.045 ± .007 (Code "H")
E	3/32 R.	1/8 R	5/32 R	1/4 R	1/4 R
F	1/32 R	1/16 R	3/32 R	1/8 R	1/8 R
D <sub>F</sub>	D <sub>C</sub> + 3/4" See Note 4	D <sub>C</sub> + 1" See Note 4	D <sub>C</sub> + 1 1/2" See Note 4	D <sub>C</sub> + 2" See Note 4	D <sub>C</sub> + 2" See Note 4

**NOTES:**

1. Stock diaphragms are supplied with a button on the pressure side 1/8" diameter X 3/32" high on bore sizes 1" and over.
2. This radius is not the piston radius since the head corner will be inverted at assembly.
3. Height should not exceed the bore (D<sub>C</sub>) . Tolerance on height to be no less than ±.015" or greater than ±.015" per inch of height.

**4. Trim tolerances.**

Hole Diameter OD Trim	
Diameter	Tolerances
0 - 1.00"	±.010"
1.01 - 3.01"	±.015"
over 3.01"	±.020"

5. Dimensions and tolerances pertain to Bellofram Rolling Diaphragms as manufactured and not to dimensions and tolerances of mating parts.

Cylinder Bore DC	Piston Diameter DP	Height H	Sidewall Thickness Wsw	Effective Pressure Area Ae (in) <sup>2</sup>	Convolution C	Maximum Half Stroke SA/SB
.25	.13	.17	.014	.02	.060	.01
.37	.18	.25	.034	.05	.095*	.01
x.37	.25	.31	B	.07	.060	.09
.37	.22	.31	.020	.06	.075	.06
.37	.25	.38	.015	.07	.060	.16
.42	.33	.37	.016	.11	.045*	.17
.43	.31	.31	.014	.10	.060	.09
.43	.31	.43	B	.10	.060	.21
.50	.37	.18	.015	.14	.065	.01
.50	.31	.24	.017	.12	.095*	.01
.50	.37	.28	.014	.14	.065	.05
.50	.37	.31	.017	.14	.065	.08
x.50	.37	.37	B	.15	.062	.15
.50	.37	.37	.020	.15	.062	.15
.50	.37	.43	.014	.15	.062	.21
.50	.37	.50	B	.15	.062	.28
.50	.31	.50	.017	.12	.094*	.23
.50	.35	.50	.017	.14	.075	.26
.52	.39	.26	.012	.16	.064	.03
.53	.34	.31	.015	.14	.095*	.04
.56	.50	.24	.017	.22	.031*	.06
.56	.41	.25	.012	.18	.076*	.01
.56	.41	.25	.020	.18	.076*	.01
.56	.41	.27	.015	.18	.076*	.02
.56	.34	.31	.014	.15	.111*	.01
.56	.43	.32	.016	.19	.062	.10
.56	.36	.36	.015	.16	.101*	.08
.56	.43	.37	.015	.19	.062	.15
.56	.36	.39	.015	.16	.101*	.11
.56	.43	.43	B	.19	.062	.21
.60	.50	.36	.017	.23	.050*	.16
.60	.38	.38	.017	.18	.110*	.08
.61	.50	.47	.014	.24	.055*	.26
.62	.50	.37	.015	.24	.062	.15
.62	.43	.37	.017	.21	.097*	.09
x.62	.50	.50	B	.24	.062	.28
.62	.50	.62	.015	.24	.062	.40
.62	.48	.66	.015	.23	.072*	.42
.62	.50	.66	.015	.24	.062	.44
.66	.54	.32	.025	.28	.060	.10
.66	.47	.53	.015	.25	.095*	.25
.67	.54	.33	.020	.28	.065	.10
.68	.56	.34	.014	.30	.062	.12
.68	.48	.47	.016	.26	.100*	.19
.69	.57	.43	.017	.31	.060	.21
.69	.56	.57	.015	.30	.065	.34
.69	.44	.69	.014	.25	.125*	.37
.71	.38	.19	.015	.23	.165*	.01
.71	.44	.25	.015	.25	.135*	.01
.71	.49	.35	.016	.28	.110*	.05
.71	.50	.37	.015	.28	.105*	.08
.71	.46	.45	.017	.26	.125*	.13
.73	.41	.54	.017	.25	.160*	.16
.74	.55	.36	.016	.32	.095*	.08
.74	.54	.44	.014	.32	.100*	.16
.74	.44	.59	.014	.27	.150*	.23
.75	.37	.15	.014	.24	.190*	.01
.75	.62	.35	.015	.36	.065	.12
.75	.62	.37	B	.36	.065	.14
.75	.56	.47	.012	.33	.095*	.19
.75	.50	.49	.016	.30	.125*	.17
.75	.62	.53	.015	.36	.065	.30
x.75	.62	.62	B	.36	.065	.39
.75	.62	.62	.020	.36	.065	.39
.75	.64	.70	.020	.37	.055*	.49
.76	.54	.08	.019	.33	.110*	.01
.77	.65	.50	.015	.39	.060	.28
.79	.58	.40	.024	.36	.105*	.11
.79	.56	.53	.016	.35	.115*	.22
.81	.68	.26	.012	.43	.065	.03
.81	.69	.69	B	.44	.060	.47
.83	.64	.32	.017	.42	.095	.04
.83	.63	.40	.022	.41	.100*	.12
.83	.71	.44	.020	.46	.060	.22
.84	.64	.59	.017	.43	.100*	.31
.86	.55	.54	.014	.39	.155*	.17
.87	.62	.12	.014	.43	.125*	.01

x Standard (Tooling Available)  
\* Special Convolution width

Cylinder Bore DC	Piston Diameter DP	Height H	Sidewall Thickness Wsw	Effective Pressure Area Ae (in) <sup>2</sup>	Convolution C	Maximum Half Stroke SA/SB
.87	.75	.28	.014	.51	.060	.06
.87	.75	.37	B	.51	.060	.15
.87	.75	.50	C	.51	.060	.28
.87	.62	.58	.015	.43	.125*	.26
X .87	.75	.75	B	.51	.060	.53
.87	.75	.87	B	.51	.060	.65
.87	.62	.87	.015	.43	.125*	.55
.87	.69	.87	.016	.47	.090*	.60
.90	.75	.55	.014	.53	.075*	.31
.91	.65	.54	.015	.47	.130*	.21
.94	.81	.33	.015	.60	.065	.10
.94	.81	.36	.014	.60	.065	.13
.94	.75	.42	.016	.56	.095*	.14
.94	.81	.81	B	.60	.065	.58
.94	.81	.94	B	.60	.065	.71
.94	.81	1.00	B	.60	.065	.77
.95	.75	.34	.017	.56	.100*	.06
.96	.72	.20	.018	.55	.120*	.01
.96	.79	.50	.014	.60	.085*	.24
.98	.82	1.00	.015	.63	.080*	.75
1.00	.62	.33	.031*	.51	.190*	.01
1.00	.81	.33	.018	.64	.095	.01
1.00	.82	.35	.016	.65	.090	.01
1.00	.81	.37	C	.64	.095	.01
1.00	.88	.37	.020	.69	.060*	.05
X 1.00	.81	.44	C	.64	.095	.06
1.00	.81	.44	.020	.64	.095	.06
X 1.00	.81	.62	C	.64	.095	.24
1.00	.80	.62	.025	.63	.100*	.24
1.00	.81	.71	.016	.64	.095	.33
1.00	.81	.75	.015	.64	.095	.37
X 1.00	.81	.81	C	.64	.095	.43
1.00	.81	.87	.015	.64	.095	.49
1.00	.81	.87	.016	.64	.095	.49
1.00	.81	.88	.017	.64	.095	.50
X 1.00	.81	1.00	C	.64	.095	.62
1.02	.78	.39	.014	.63	.120*	.01
1.04	.80	.25	.014	.66	.120*	.01
1.06	.85	.48	.012	.71	.105	.09
1.06	.87	.62	.017	.73	.095	.24
1.06	.87	1.03	.015	.73	.095	.65
1.06	.87	1.06	C	.73	.095	.68
1.07	.98	.37	.012	.82	.045*	.07
1.08	.75	.22	.017	.65	.165*	.01
1.08	.87	.35	.017	.74	.105*	.01
1.09	.91	.52	.022	.78	.090	.15
1.10	.94	.40	.011	.81	.080*	.05
1.12	.97	.36	.014	.85	.075*	.01
1.12	.97	.37	.015	.85	.075*	.02
1.12	.94	.44	.022	.83	.090	.07
X 1.12	.94	.44	C	.83	.090	.07
1.12	.86	.62	C	.76	.130*	.19
1.12	.94	.62	C	.83	.090	.25
1.12	.93	.62	.020	.82	.095	.24
1.12	.94	.66	C	.83	.090	.29
X 1.12	.94	.69	C	.83	.090	.32
1.12	.94	.75	.020	.83	.090	.38
1.12	.94	.87	C	.83	.090	.50
X 1.12	.94	.94	C	.83	.090	.57
1.12	.88	1.12	C	.78	.120*	.70
X 1.12	.94	1.12	C	.83	.090	.75
1.12	.87	1.12	.020	.77	.125*	.70
1.14	.95	.50	.017	.85	.095	.12
1.16	.78	.32	.017	.73	.065	.01
1.16	.91	.38	.016	.84	.125*	.01
1.17	1.03	.28	.016	.95	.070*	.01
1.17	.89	.38	.011	.83	.140*	.01
1.17	.99	.50	B	.91	.090	.13
1.18	1.03	.45	.014	.95	.075*	.10
1.18	1.00	1.05	.018	.93	.090	.68
1.19	1.00	.44	C	.94	.095	.06
1.19	1.00	.50	C	.94	.095	.12
1.19	1.00	.69	C	.94	.095	.31
1.19	1.00	1.00	C	.94	.095	.62
1.19	1.00	1.19	C	.94	.095	.81
1.21	1.04	.40	.017	.99	.085*	.04
1.22	1.03	.45	.014	.99	.095	.07

Side Wall Thickness B = approx. .015 C = approx. .017  
D = approx. .024 F = approx. .035 H = approx. .045

Cylinder Bore DC	Piston Diameter DP	Height H	Sidewall Thickness Wsw	Effective Pressure Area Ae (in) <sup>2</sup>	Convolution C	Maximum Half Stroke SA/SB
1.24	1.02	.28	.015	1.00	.110*	.01
1.24	.98	.37	.015	.96	.130*	.01
1.24	1.08	.38	.023	1.05	.080*	.03
1.25	1.00	.31	.020	.99	.125*	.01
1.25	1.10	.34	.018	1.08	.075*	.01
1.25	.94	.37	.015	.94	.155*	.01
1.25	1.06	.37	C	1.04	.095	.01
1.25	1.06	.44	C	1.04	.095	.06
1.25	.94	.45	.022	.94	.155*	.01
X 1.25	1.06	.50	C	1.04	.095	.12
1.25	1.06	.62	C	1.04	.095	.24
X 1.25	1.06	.75	C	1.04	.095	.37
1.25	.95	.79	.024	.95	.150*	.33
1.25	1.06	.83	C	1.04	.095	.45
1.25	1.06	.97	C	1.04	.095	.59
X 1.25	1.06	1.00	C	1.04	.095	.62
X 1.25	1.06	1.25	C	1.04	.095	.87
1.28	1.16	.38	C	1.16	.060*	.06
1.28	1.06	.51	C	1.07	.110*	.11
1.31	1.07	.33	.011	1.11	.120*	.01
1.31	1.12	.44	C	1.15	.095	.06
1.31	1.12	.56	C	1.15	.095	.18
1.31	1.12	.81	C	1.15	.095	.43
1.31	1.12	1.06	C	1.15	.095	.68
1.31	1.12	1.31	C	1.15	.095	.93
1.33	1.06	.21	.011	1.12	.135*	.01
1.33	1.06	.21	.015	1.12	.135*	.01
1.33	1.06	.26	.012	1.12	.135*	.01
1.33	1.06	.44	.012	1.12	.135*	.01
1.33	1.19	1.06	.035	1.24	.070*	.72
1.34	1.21	.39	.014	1.27	.065*	.06
1.36	1.20	.53	.017	1.28	.080	.18
1.36	1.12	1.16	.020	1.20	.120*	.74
X 1.37	1.19	.44	C	1.28	.090	.07
X 1.37	1.19	.56	C	1.28	.090	.19
1.37	1.19	.75	C	1.28	.090	.38
1.37	1.12	.75	C	1.21	.125*	.33
X 1.37	1.19	.87	C	1.28	.090	.50
1.37	1.19	1.00	C	1.28	.090	.63
X 1.37	1.19	1.12	C	1.28	.090	.75
X 1.37	1.19	1.37	C	1.28	.090	1.00
1.37	1.19	1.37	D	1.28	.090	1.00
1.37	1.19	.50	.028	1.28	.090	.13
1.38	1.16	.48	.017	1.26	.110*	.08
1.38	1.16	.48	.017	1.26	.110*	.08
1.40	.37	.87	.020	.61	.515*	.01
1.42	1.29	.51	.020	1.44	.065	.18
1.42	1.09	.24	.013	1.23	.165*	.01
1.44	1.25	.44	C	1.42	.095	.06
1.44	1.25	.62	C	1.42	.095	.24
1.44	1.25	.94	C	1.42	.095	.56
1.44	1.25	1.19	C	1.42	.095	.81
1.44	1.25	1.44	C	1.42	.095	1.06
1.44	1.19	1.49	D	1.35	.125*	1.07
1.45	.84	.31	.011	1.02	.305*	.01
1.46	1.08	.42	.011	1.26	.190*	.01
1.46	1.28	.45	.014	1.47	.090	.08
1.47	1.30	.66	.017	1.50	.085*	.30
1.47	1.23	1.64	.025	1.43	.120*	1.22
1.48	1.28	.35	.017	1.49	.100*	.01
X 1.50	1.31	.44	C	1.55	.095	.06
1.50	1.39	.44	C	1.63	.055*	.13
1.50	1.31	.52	.014	1.55	.095	.14
1.50	1.31	.62	B	1.55	.095	.24
X 1.50	1.31	.62	C	1.55	.095	.24
1.50	1.00	.67	.016	1.22	.250*	.05
1.50	1.31	.75	C	1.55	.095	.37
X 1.50	1.31	.94	C	1.55	.095	.56
1.50	1.16	.94	.028	1.38	.170*	.45
1.50	1.25	.94	.028	1.48	.125*	.52
1.50	1.31	.94	.028	1.55	.095	.56
1.50	1.20	1.06	.017	1.43	.150*	.60
1.50	1.31	1.12	C	1.55	.095	.74
1.50	1.31	1.25	C	1.55	.094	.87
X 1.50	1.31	1.50	C	1.55	.095	1.12
1.51	1.37	.64	.020	1.62	.070*	.30
1.53	1.21	.59	.016	1.47	.160*	.11
1.54	1.28	.57	.016	1.56	.130*	.14
1.56	1.37	.44	C	1.68	.095	.06
1.56	1.37	.69	C	1.68	.095	.31
1.56	1.37	1.00	C	1.68	.095	.62
1.56	1.37	1.31	C	1.68	.095	.93
1.56	1.37	1.56	C	1.68	.095	1.18

x Standard (Tooling Available)  
\* Special Convolution width

Cylinder Bore DC	Piston Diameter DP	Height H	Sidewall Thickness Wsw	Effective Pressure Area Ae (in) <sup>2</sup>	Convolution C	Maximum Half Stroke SA/SB
1.56	1.24	1.55	.017	1.53	.160*	1.07
1.56	1.28	1.55	.017	1.58	.140*	1.10
1.58	1.31	.27	.012	1.63	.135*	.01
1.58	1.31	.35	.013	1.63	.135*	.01
1.58	1.44	.78	.012	1.79	.070*	.54
1.59	1.20	.67	.015	1.52	.195*	.14
1.59	1.31	2.10	.016	1.65	.140*	1.65
1.61	1.29	.40	.022	1.65	.160*	.01
X 1.62	1.44	.44	C	1.83	.090	.07
X 1.62	1.44	.69	C	1.83	.090	.32
X 1.62	1.44	1.00	C	1.83	.090	.63
X 1.62	1.44	1.37	C	1.83	.090	1.00
X 1.62	1.44	1.62	C	1.83	.090	1.25
1.65	1.31	.74	.022	1.72	.170*	.25
1.66	1.50	.64	.022	1.96	.080*	.29
1.66	1.28	.69	.017	1.69	.190*	.16
1.67	1.32	.70	.015	1.75	.175*	.20
1.67	1.48	1.66	.017	1.94	.095	1.28
1.68	1.50	.44	C	1.98	.090	.07
1.68	1.50	.55	.016	1.99	.093	.18
1.68	1.50	.75	C	1.99	.093	.38
1.68	1.50	1.06	C	1.99	.093	.69
1.68	1.50	1.44	C	1.99	.093	1.07
1.68	1.50	1.68	C	1.99	.093	1.31
1.70	1.38	1.32	.017	1.86	.160*	.84
1.70	1.46	1.64	.025	1.96	.120*	1.22
1.72	1.56	.45	.017	2.11	.080*	.10
1.75	1.31	.27	.012	1.83	.220*	.01
X 1.75	1.56	.44	C	2.15	.095	.06
1.75	1.56	.45	B	2.15	.095	.07
1.75	1.56	.53	C	2.15	.095	.15
1.75	1.56	.75	.020	2.15	.095	.37
X 1.75	1.56	.75	C	2.15	.095	.37
X 1.75	1.56	1.06	C	2.15	.095	.68
1.75	1.56	1.17	C	2.15	.095	.79
1.75	1.50	1.20	.015	2.07	.125*	.78
1.75	1.56	1.25	C	2.15	.095	.87
1.75	1.56	1.44	B	2.15	.095	1.06
X 1.75	1.56	1.44	C	2.15	.095	1.06
X 1.75	1.56	1.75	C	2.15	.095	1.37
1.78	1.61	.29	.016	2.25	.085*	.01
1.78	1.53	.75	.016	2.15	.125*	.33
1.80	1.60	.55	.017	2.26	.100*	.17
1.80	1.60	1.00	C	2.26	.100*	.62
1.83	1.69	.66	.022	2.43	.070*	.32
1.84	1.55	.69	.016	2.25	.145*	.23
1.87	1.69	.44	C	2.48	.090	.07
1.87	1.68	.50	.017	2.47	.095	.12
1.87	1.69	.52	.016	2.48	.090	.15
1.87	1.69	.62	C	2.48	.090	.25
1.87	1.69	.65	.011	2.48	.090	.28
1.87	1.69	.81	C	2.48	.090	.44
1.87	1.69	1.12	C	2.48	.090	.75
1.87	1.69	1.25	C	2.48	.090	.88
1.87	1.69	1.50	C	2.48	.090	1.13
1.87	1.69	1.87	C	2.48	.090	1.50
1.87	1.69	2.37	C	2.48	.090	2.00
1.88	1.54	1.86	.022	2.29	.170*	1.37
1.88	1.65	1.86	.022	2.44	.115*	1.45
1.90	1.64	1.25	C	2.46	.130*	.82
1.90	1.66	1.25	.020	2.48	.120*	.83
1.90	1.68	1.37	B	2.51	.110*	.97
1.91	1.66	.56	.017	2.50	.125*	.14
1.91	1.62	.68	.016	2.44	.145*	.22
X 2.00	1.81	.44	C	2.85	.095	.06
2.00	1.81	.50	.017	2.85	.095	.12
2.00	1.80	.56	D	2.83	.100*	.18
2.00	1.81	.75	C	2.85	.095	.37
X 2.00	1.81	.81	C	2.85	.095	.43
2.00	1.75	.90	.020	2.76	.125*	.48
2.00	1.68	.91	C	2.65	.160*	.43
2.00	1.81	1.00	C	2.85	.095	.62
2.00	1.75	1.12	C	2.76	.125*	.70
X 2.00	1.81	1.25	C	2.85	.095	.87
2.00	1.81	1.29	.016	2.85	.095	.91
2.00	1.81	1.35	.020	2.85	.095	.97
2.00	1.75	1.50	F	2.76	.125*	1.08
2.00	1.81	1.50	C	2.85	.095	1.12
2.00	1.75	1.58	D	2.76	.125*	1.16
2.00	1.69	1.62	C	2.67	.155*	1.15
X 2.00	1.81	1.62	C	2.85	.095	1.24
2.00	1.81	1.62	B	2.85	.095	1.24
2.00	1.77	1.70	.025	2.79	.115*	1.29

Side Wall Thickness D = approx. .024  
B = approx. .015  
F = approx. .035  
C = approx. .017  
H = approx. .045

# 10 Bellofram

ORIGINATOR OF THE ROLLING DIAPHRAGM

Cylinder Bore DC	Piston Diameter DP	Height H	Sidewall Thickness Wsw	Effective Pressure Area Ae (in) <sup>2</sup>	Convolution C	Maximum Half Stroke SA/SB
2.00	1.62	2.00	C	2.57	.190*	1.47
X 2.00	1.81	2.00	C	2.85	.095	1.62
2.04	1.85	.36	.022	2.97	.095	.01
2.05	1.80	.99	.022	2.91	.125*	.57
2.06	1.72	.79	.016	2.80	.170*	.30
2.07	1.73	.52	.017	2.83	.170*	.03
2.07	1.80	.75	.017	2.94	.135*	.31
2.12	2.07	.28	.020	3.44	.025*	.01
2.12	1.82	.57	.017	3.04	.150*	.11
2.12	1.94	.62	C	3.23	.090	.25
2.12	1.94	.87	C	3.23	.090	.50
2.12	1.94	1.31	C	3.23	.090	.94
2.12	1.94	1.75	C	3.23	.090	1.38
2.12	1.94	2.12	C	3.23	.090	1.75
2.23	1.93	.62	D	3.39	.150*	.16
X 2.25	2.06	.62	C	3.64	.095	.24
2.25	2.06	.75	C	3.64	.095	.37
X 2.25	2.06	.94	C	3.64	.095	.56
2.25	2.06	1.00	C	3.64	.095	.62
2.25	2.06	1.03	C	3.64	.095	.65
2.25	.50	1.25	.024	1.48	.875*	.01
X 2.25	2.06	1.37	C	3.64	.095	.99
X 2.25	2.06	1.81	C	3.64	.095	1.43
X 2.25	2.06	2.25	C	3.64	.095	1.87
2.25	1.87	2.25	.016	3.33	.190*	1.72
2.27	2.00	.61	.024	3.58	.135*	.17
2.27	2.08	.62	.016	3.71	.095	.24
2.31	2.12	.69	.014	3.85	.095	.31
2.31	2.04	2.17	.018	3.71	.135*	1.73
2.34	2.15	1.70	.025	3.95	.095	1.32
2.37	2.13	.75	B	3.97	.120*	.33
2.37	2.19	1.00	C	4.08	.090	.63
2.37	2.06	1.12	C	3.85	.155*	.65
2.37	2.19	1.44	C	4.08	.090	1.07
2.37	2.19	1.87	C	4.08	.090	1.50
2.37	2.00	2.00	F	3.74	.185*	1.48
2.37	2.19	2.37	C	4.08	.090	2.00
2.38	2.13	1.17	C	3.99	.125*	.17
2.42	2.06	1.32	.023	3.94	.180*	.17
2.43	2.26	.41	.017	4.31	.085*	.05
2.43	2.06	1.44	.022	3.95	.185*	.92
2.43	2.25	1.50	C	4.30	.090	1.13
2.44	2.12	1.22	.017	4.08	.160*	.74
2.44	2.19	1.22	.017	4.20	.125*	.80
2.44	2.25	1.22	.017	4.31	.095	.84
2.46	2.25	.97	.017	4.35	.105*	.58
2.47	2.21	1.72	.020	4.30	.130*	1.29
2.50	2.31	.37	.014	4.54	.095	.01
X 2.50	2.31	.62	C	4.54	.095	.24
2.50	2.31	.62	D	4.54	.095	.24
2.50	2.31	.68	C	4.54	.095	.30
2.50	2.31	.68	C	4.54	.095	.30
2.50	2.31	.71	.012	4.54	.095	.33
2.50	2.31	.71	.017	4.54	.095	.33
2.50	2.31	.75	C	4.54	.095	.37
2.50	2.31	.86	.017	4.54	.095	.48
2.50	2.31	1.00	C	4.54	.095	.62
2.50	2.31	1.00	.023	4.54	.095	.62
2.50	2.31	1.06	D	4.54	.095	.68
X 2.50	2.31	1.06	C	4.54	.095	.68
2.50	2.00	1.14	.016	3.97	.250*	.52
2.50	2.31	1.42	.016	4.54	.095	1.04
X 2.50	2.31	1.50	C	4.54	.095	1.12
2.50	2.00	1.53	.020	3.97	.250*	.91
2.50	2.31	1.75	C	4.54	.095	1.37
2.50	2.19	1.94	.014	4.31	.155*	1.47
X 2.50	2.31	2.00	C	4.54	.095	1.62
X 2.50	2.31	2.50	C	4.54	.095	2.12
2.50	2.21	2.50	C	4.35	.145*	2.04
2.50	2.12	2.50	.020	4.19	.190*	1.97
2.51	2.30	.68	C	4.54	.105*	.21
2.55	2.12	1.85	.022	4.28	.215*	1.20
2.59	2.19	1.03	.016	4.48	.200*	.41
2.59	2.19	1.30	.017	4.48	.200*	.68
2.61	2.34	1.63	.020	4.81	.135*	1.11
2.62	2.43	.43	.016	5.00	.095*	.01
2.62	2.31	.88	.020	4.77	.155	.33
2.62	2.31	1.12	D	4.77	.155	.57
2.62	2.44	1.25	.020	5.02	.090*	.80
2.62	2.31	1.56	D	4.77	.155	1.01
2.62	2.31	1.70	D	4.77	.155	1.15
2.62	2.31	2.12	D	4.77	.155	1.57
2.62	2.31	2.62	D	4.77	.155	2.07

x Standard (Tooling Available)  
\* Special Convolution width

Cylinder Bore DC	Piston Diameter DP	Height H	Sidewall Thickness Wsw	Effective Pressure Area Ae (in) <sup>2</sup>	Convolution C	Maximum Half Stroke SA/SB
2.62	2.29	2.75	.024	4.73	.165*	2.18
2.67	2.46	1.35	.020	5.16	.105*	.88
2.69	2.51	.97	.024	5.30	.090*	.52
2.69	2.31	1.19	.024	4.90	.190*	.58
2.75	2.50	1.10	C	5.41	.125*	.59
X 2.75	2.44	1.12	D	5.28	.155	.57
X 2.75	2.44	1.62	D	5.28	.155	1.07
2.75	2.50	1.75	D	5.41	.125*	1.24
2.75	2.44	1.87	D	5.28	.155	1.32
x 2.75	2.44	2.25	D	5.28	.155	1.70
x 2.75	2.44	2.75	D	5.28	.155	2.20
2.77	1.76	.75	.045	4.02	.505*	.01
2.77	2.45	1.32	.017	5.35	.160*	.76
2.78	2.37	1.12	.022	5.20	.205*	.49
2.81	2.31	.86	.023	5.14	.250*	.16
2.83	2.31	.48	.075	5.18	.260*	.01
2.87	2.56	1.12	.020	5.78	.155	.57
2.87	2.56	1.31	D	5.78	.155	.76
2.87	2.56	1.69	D	5.78	.155	1.14
2.87	2.50	2.31	D	5.66	.185*	1.71
2.87	2.50	2.50	F	5.66	.185*	1.90
2.87	2.56	2.87	D	5.78	.155	2.32
2.89	2.84	.90	.025	6.44	.025*	.55
2.93	2.87	.59	.035	6.60	.030*	.23
2.93	2.88	.59	.026	6.62	.025*	.24
2.93	2.71	2.20	.016	6.24	.110*	1.72
3.00	1.40	.69	.022	3.80	.800*	.01
3.00	2.69	1.00	D	6.35	.155	.45
3.00	2.69	1.19	C	6.35	.155	.64
x 3.00	2.69	1.19	D	6.35	.155	.64
3.00	2.69	1.47	D	6.35	.155	.92
3.00	2.69	1.75	C	6.35	.155	1.20
x 3.00	2.69	1.75	D	6.35	.155	1.20
3.00	2.69	1.86	.022	6.35	.155	1.31
3.00	2.50	2.00	.042	5.93	.250*	1.30
3.00	2.69	2.00	D	6.35	.155	1.45
3.00	2.75	2.00	.025	6.49	.125*	1.49
3.00	2.56	2.12	.020	6.06	.220*	1.47
3.00	2.75	2.12	C	6.49	.125*	1.61
x 3.00	2.69	2.37	D	6.35	.155	1.82
3.00	2.63	3.00	D	6.22	.185	2.40
3.00	2.69	3.00	.030	6.35	.155	2.45
x 3.00	2.69	3.00	D	6.35	.155	2.45
3.00	2.75	3.00	D	6.49	.125*	2.49
3.03	2.72	2.41	.019	6.49	.155	1.86
3.06	3.02	1.56	.022	7.25	.020*	1.22
3.10	2.78	1.19	.020	6.78	.160*	.63
3.12	2.94	.74	.019	7.21	.090*	.29
3.12	2.81	1.25	D	6.90	.155	.70
3.12	2.81	1.87	D	6.90	.155	1.32
3.12	2.81	3.12	D	6.90	.155	2.57
3.19	2.81	1.25	.020	1.06	.190*	.64
3.23	3.02	.54	.022	7.66	.105*	.07
3.25	2.94	1.31	D	7.52	.155	.76
3.25	2.94	1.50	C	7.52	.155	.95
x 3.25	2.94	1.94	D	7.52	.155	1.39
3.25	3.00	2.12	D	7.66	.125	1.61
3.25	2.94	2.62	D	7.52	.155	2.07
x 3.25	2.94	3.25	D	7.52	.155	2.70
3.27	2.85	2.05	.020	7.35	.210*	1.41
3.28	2.75	1.20	.017	7.13	.265*	.48
3.28	2.75	1.47	.018	7.13	.265*	.75
3.37	3.06	1.00	D	8.11	.155	.45
3.37	3.06	1.00	.018	8.11	.155	.45
3.37	3.06	1.37	D	8.11	.155	.82
3.37	3.06	2.00	D	8.11	.155	1.45
3.37	3.06	2.75	D	8.11	.155	2.20
3.37	3.06	3.00	.030	8.11	.155	2.45
3.37	3.06	3.37	D	8.11	.155	2.82
3.40	3.09	1.37	D	8.27	.155	.82
3.43	2.94	.51	.022	7.96	.245*	.01
3.43	2.94	.71	.022	7.96	.245*	.02
3.43	3.16	.79	.022	8.28	.135*	.27
x 3.50	3.25	.34	.034	8.94	.125*	.01
x 3.50	3.19	1.00	D	8.78	.155	.45
3.50	3.25	1.01	C	8.94	.125*	.50
3.50	3.25	1.12	D	8.94	.125*	.61
3.50	3.19	1.25	D	8.78	.155	.70
3.50	3.19	1.44	D	8.78	.155	.89
3.50	3.19	1.50	D	8.78	.155	.95
3.50	3.19	1.87	D	8.78	.155	1.32
x 3.50	3.19	2.12	D	8.78	.155	1.57
3.50	3.03	2.24	.019	8.37	.235*	1.56

Side Wall Thickness D = approx. .024  
B = approx. .015  
F = approx. .035  
C = approx. .017  
H = approx. .045

Cylinder Bore DC	Piston Diameter DP	Height H	Sidewall Thickness Wsw	Effective Pressure Area Ae (in) <sup>2</sup>	Convolution C	Maximum Half Stroke SA/SB
3.50	3.19	2.24	.019	8.78	.155	1.69
3.50	3.25	2.25	D	8.94	.125*	1.74
3.50	3.19	2.81	D	8.78	.155	2.26
x 3.50	3.19	3.50	D	8.78	.155	2.95
3.53	3.15	.74	B	8.76	.190*	.13
3.58	3.11	1.12	.022	8.78	.235*	.44
3.58	3.31	1.28	.016	9.32	.135*	.76
3.62	3.31	.77	D	9.42	.155	.22
3.62	3.31	1.00	D	9.42	.155	.45
3.62	3.31	1.50	D	9.42	.155	.95
3.62	3.31	2.19	D	9.42	.155	1.64
3.62	3.31	3.62	D	9.42	.155	3.07
3.63	3.13	1.37	.023	8.97	.250*	.67
3.64	3.44	2.19	.018	9.84	.100*	1.72
3.68	2.69	3.19	.021	7.96	.495*	2.11
3.69	2.94	1.28	.016	8.63	.375*	.38
3.75	3.25	1.00	.012	9.62	.250*	.30
x 3.75	3.44	1.00	D	10.15	.155	.45
3.75	3.44	1.25	D	10.15	.155	.70
3.75	3.50	1.25	D	10.32	.125*	.74
3.75	3.44	1.32	.022	10.15	.155	.77
3.75	3.25	1.39	C	9.62	.250*	.69
3.75	3.44	1.50	D	10.15	.155	.95
3.75	3.25	1.65	C	9.62	.250*	.95
x 3.75	3.44	2.25	D	10.15	.155	1.70
3.75	3.44	3.00	D	10.15	.155	2.45
x 3.75	3.44	3.75	D	10.15	.155	3.20
3.75	3.50	3.75	D	10.32	.125*	3.24
3.87	3.56	1.00	D	10.83	.155	.45
3.87	3.56	1.56	D	10.83	.155	1.01
3.87	3.56	2.37	D	10.83	.155	1.82
3.87	3.56	3.12	D	10.83	.155	2.57
3.87	3.56	3.87	D	10.83	.155	3.32
3.89	3.68	1.62	.022	11.25	.105*	1.15
3.97	3.60	.52	.015	11.25	.185*	.01
4.00	3.69	1.00	.020	11.61	.155	.45
x 4.00	3.69	1.00	D	11.61	.155	.45
4.00	3.69	1.28	.055	11.61	.155	.73
4.00	3.69	1.37	D	11.61	.155	.82
4.00	3.75	1.50	.020	11.79	.125*	.99
4.00	3.75	1.50	D	11.79	.125*	.99
4.00	3.69	1.62	D	11.61	.155	1.07
4.00	3.80	1.62	D	11.94	.100*	1.15
4.00	3.69	2.14	.018	11.61	.155	1.59
4.00	3.69	2.44	F	11.61	.155	1.89
x 4.00	3.69	2.44	D	11.61	.155	1.89
4.00	3.50	2.44	.024	11.04	.250*	1.74
4.00	3.75	2.75	D	11.79	.125*	2.24
4.00	3.69	3.25	D	11.61	.155	2.70
x 4.00	3.69	4.00	D	11.61	.155	3.45
4.00	3.75	4.00	F	11.79	.125*	3.49
4.03	3.65	1.87	D	11.58	.190*	1.28
4.11	3.62	2.12	.024	11.73	.245	1.34
4.12	3.62	1.00	F	11.76	.250	.22
4.12	3.62	1.62	F	11.76	.250	.84
4.12	3.62	2.50	F	11.76	.250	1.72
4.12	3.62	3.31	F	11.76	.250	2.53
4.12	3.82	4.12	F	11.76	.250	3.34
4.20	3.62	.90	.012	12.62	.190*	.21
4.24	3.78	1.30	.032	12.62	.230*	.55
4.25	3.75	.94	.015	12.56	.250	.16
4.25	3.75	1.00	F	12.56	.250	.22
4.25	4.00	1.25	.025	13.36	.125*	.66
4.25	3.75	1.37	F	12.56	.250	.59
4.25	3.75	1.69	F	12.56	.250	.91
4.25	3.75	2.62	F	12.56	.250	1.84
4.25	3.75	3.37	F	12.56	.250	2.59
4.25	3.75	4.25	F	12.56	.250	3.47
4.37	3.87	1.00	F	13.33	.250	.22
4.37	3.87	1.69	F	13.33	.250	.91
4.37	3.87	2.10	B	13.33	.250	1.32
4.37	3.87	2.69	F	13.33	.250	1.91
4.37	3.87	3.50	F	13.33	.250	2.72
4.37	3.87	4.37	F	13.33	.250	3.59
4.44	4.20	.55	.017	14.65	.120*	.01
x 4.50	4.00	1.00	F	14.18	.250	.22
4.50	2.50	1.00	.022	9.62	1.000*	.01
4.50	4.00	1.19	F	14.18	.250	.41
4.50	4.00	1.50	F	14.18	.250	.7
4.50	4.21	1.59	.024	14.89	.145	.97
4.50	4.00	1.81	F	14.18	.250	1.03
x 4.50	4.00	2.75	F	14.18	.250	1.97
4.50	4.00	3.00	.020	14.18	.250	2.22

Cylinder Bore DC	Piston Diameter DP	Height H	Sidewall Thickness Wsw	Effective Pressure Area Ae (in) <sup>2</sup>	Convolution C	Maximum Half Stroke SA/SB
4.50	4.25	3.00	D	15.03	.125*	2.41
4.50	4.00	3.62	F	14.18	.250	2.84
x 4.50	4.00	4.50	F	14.18	.250	3.72
4.50	4.25	4.50	.025	15.03	.125*	3.91
4.62	4.12	1.00	F	14.99	.250	.22
4.62	4.12	1.81	.016	14.99	.250	1.03
4.62	4.12	1.81	F	14.99	.250	1.03
4.62	4.12	2.81	F	14.99	.250	2.03
4.62	3.00	3.09	F	11.40	.810*	1.43
4.62	4.12	3.69	F	14.99	.250	2.91
4.62	4.12	4.62	F	14.99	.250	3.84
4.67	4.31	2.19	.014	15.83	.180*	1.51
4.70	4.30	2.63	.025	15.90	.200*	1.92
4.75	4.25	1.00	F	15.90	.250	.22
4.75	4.25	1.06	F	15.90	.250	.28
4.75	4.25	1.50	F	15.90	.250	.72
4.75	4.25	1.87	F	15.90	.250	1.09
4.75	4.25	2.87	F	15.90	.250	2.09
4.75	4.25	3.75	F	15.90	.250	2.97
4.75	4.25	4.75	F	15.90	.250	3.97
4.87	4.37	1.00	F	16.76	.250	.22
4.87	4.37	1.87	F	16.76	.250	1.09
4.87	4.37	2.94	F	16.76	.250	2.16
4.87	4.37	3.87	F	16.76	.250	3.09
4.87	4.37	4.87	F	16.76	.250	4.09
x 5.00	4.50	1.00	F	17.72	.250	.22
5.00	4.50	1.62	F	17.72	.250	.84
5.00	4.50	2.00	F	17.72	.250	1.22
5.00	4.75	2.50	D	18.66	.125*	1.91
x 5.00	4.50	3.00	F	17.72	.250	2.22
5.00	4.50	4.00	F	17.72	.250	3.22
5.00	4.75	4.75	D	18.66	.125*	4.16
x 5.00	4.50	5.00	F	17.72	.250	4.22
5.06	4.56	1.25	.032	18.17	.250	.47
5.12	4.62	1.12	F	18.62	.250	.34
5.12	4.62	2.00	F	18.62	.250	1.22
5.12	4.62	3.12	F	18.62	.250	2.34
5.12	4.62	4.12	F	18.62	.250	3.34
5.12	4.62	5.12	F	18.62	.250	4.34
5.25	4.75	1.12	F	19.63	.250	.34
5.25	4.75	1.62	F	19.63	.250	.84
5.25	4.75	2.12	F	19.63	.250	1.34
5.25	4.75	3.19	F	19.63	.250	2.41
5.25	4.75	4.25	F	19.63	.250	3.47
5.25	4.75	5.25	F	19.63	.250	4.47
5.37	4.87	1.12	F	20.58	.250	.34
5.37	4.87	2.12	F	20.58	.250	1.34
5.37	4.87	3.31	F	20.58	.250	2.53
5.37	4.87	4.37	F	20.58	.250	3.59
5.37	4.87	5.37	F	20.58	.250	4.59
5.50	5.00	1.00	F	21.64	.250	.22
x 5.50	5.00	1.12	F	21.64	.250	.34
5.50	5.00	1.75	F	21.64	.250	.97
5.50	5.00	2.25	F	21.64	.250	1.47
5.50	5.00	2.40	F	21.64	.250	1.62
5.50	5.23	2.50	F	22.60	.135*	1.89
5.50	5.25	2.50	D	22.69	.125*	1.91
5.50	5.00	2.53	F	21.64	.250	1.75
x 5.50	5.00	3.37	F	21.64	.250	2.59
5.50	5.00	4.44	F	21.64	.250	3.66
5.50	5.25	5.00	.025	22.69	.125*	4.41
5.50	5.00	5.50	F	21.64	.250	4.72
5.59	5.25	1.82	C	23.07	.170*	1.16
5.62	5.12	1.12	F	22.64	.250	.34
5.62	5.12	2.25	F	22.64	.250	1.47
5.62	5.12	3.44	F	22.64	.250	2.66
5.62	5.12	4.50	F	22.64	.250	3.72
5.62	5.12	5.62	F	22.64	.250	4.84
5.75	5.25	1.25	D	23.75	.250	.47
5.75	5.25	1.25	F	23.75	.250	.47
5.75	5.25	1.87	F	23.75	.250	1.09
5.75	5.25	2.37	F	23.75	.250	1.59
5.75	5.25	3.50	F	23.75	.250	2.72
5.75	5.25	4.56	F	23.75	.250	3.97
5.75	5.25	5.75	F	23.75	.250	4.78
5.87	5.37	1.25	F	24.80	.250	.47
5.87	5.37	2.37	F	24.80	.250	1.59
5.87	5.37	3.56	F	24.80	.250	2.78
5.87	5.37	4.75	F	24.80	.250	3.97
5.87	5.37	5.87	F	24.80	.250	5.09
6.00	5.50	1.00	F	25.96	.250	.22
x 6.00	5.50	1.25	F	25.96	.250	.47
6.00	5.50	1.87	F	25.96	.250	1.09

x Standard (Tooling Available)  
\* Special Convolution width

Side Wall Thickness D = approx. .024  
B = approx. .015  
F = approx. .035  
C = approx. .017  
H = approx. .045

Cylinder Bore DC	Piston Diameter DP	Height H	Sidewall Thickness Wsw	Effective Pressure Area Ae (in) <sup>2</sup>	Convolution C	Maximum Half Stroke SA/SB
6.00	5.50	2.50	F	25.96	.250	1.72
6.00	5.75	3.00	.020	27.10	.125*	2.41
x 6.00	5.50	3.62	F	25.96	.250	2.84
6.00	5.50	4.81	F	25.96	.250	4.03
x 6.00	5.50	6.00	F	25.96	.250	5.22
6.09	5.04	2.00	D	24.32	.525*	.79
6.12	5.87	1.00	.023	28.22	.125*	.41
6.16	5.74	1.68	.014	27.80	.210*	.96
6.25	5.75	1.50	F	28.27	.250	.72
6.25	5.75	2.75	F	28.27	.250	1.97
6.25	5.75	4.00	F	28.27	.250	3.22
6.25	5.75	5.00	F	28.27	.250	4.22
6.25	5.75	6.25	F	28.27	.250	5.47
6.50	6.00	1.00	F	30.67	.250	.22
6.50	6.19	1.25	F	31.61	.155*	.61
6.50	6.00	1.50	F	30.67	.250	.72
6.50	6.00	2.25	F	30.67	.250	1.47
6.50	6.00	3.00	F	30.67	.250	2.22
6.50	6.25	3.00	F	31.91	.125*	2.41
6.50	6.00	4.25	F	30.67	.250	3.47
6.50	6.00	5.25	F	30.67	.250	4.47
6.50	6.25	6.00	F	31.91	.125*	5.41
6.50	6.00	6.50	F	30.67	.250	5.72
6.56	5.44	2.12	F	28.27	.560*	.85
6.62	6.12	2.25	D	31.86	.250	1.47
6.75	6.25	1.75	F	33.18	.250	.97
6.75	6.25	3.25	F	33.18	.250	2.47
6.75	6.25	4.50	F	33.18	.250	3.72
6.75	6.25	5.50	F	33.18	.250	4.72
6.75	6.25	6.75	F	33.18	.250	5.97
7.00	6.50	1.00	F	35.78	.250	.22
7.00	6.50	1.37	F	35.78	.250	.59
7.00	6.50	1.75	F	35.78	.250	.97
7.00	6.62	1.92	F	36.42	.190*	1.23
7.00	6.50	2.62	F	35.78	.250	1.84
7.00	6.50	3.50	F	35.78	.250	2.72
7.00	6.75	3.50	D	37.12	.125*	2.91
7.00	6.50	4.75	F	35.78	.250	3.97
7.00	6.50	5.75	F	35.78	.250	4.97
7.00	6.50	7.00	F	35.78	.250	6.22
7.00	6.75	7.00	F	37.12	.125*	6.41
7.25	6.75	.58	.024	38.48	.250	.01
7.25	6.75	2.00	F	38.48	.250	1.22
7.25	6.75	2.34	F	38.48	.250	1.56
7.25	6.75	3.75	F	38.48	.250	2.97
7.25	6.75	5.00	F	38.48	.250	4.22
7.25	6.75	6.00	F	38.48	.250	5.22
7.25	6.75	7.25	F	38.48	.250	6.47
7.50	6.25	1.00	H	37.12	.625*	.01
7.50	7.00	1.00	F	41.28	.250	.22
7.50	7.00	1.50	F	41.28	.250	.72
7.50	6.75	1.75	F	39.87	.375*	.77
7.50	7.00	2.00	F	41.28	.250	1.22
7.50	6.75	2.50	.038	39.87	.375*	1.52
7.50	7.00	3.00	F	41.28	.250	2.22
7.50	7.25	3.50	D	42.71	.125*	2.91
7.50	7.00	4.00	F	41.28	.250	3.22
7.50	7.00	5.25	F	41.28	.250	4.47
7.50	7.00	6.25	F	41.28	.250	5.47
7.50	7.00	7.50	F	41.28	.250	6.72
7.75	7.25	2.25	F	47.17	.250	1.47
7.75	7.25	4.25	F	47.17	.250	3.47
7.75	7.25	5.50	F	47.17	.250	4.72
7.75	7.25	6.50	F	47.17	.250	5.72
8.00	7.50	1.25	F	47.17	.250	.47
8.00	7.50	2.00	F	47.17	.250	1.22
8.00	7.50	2.25	F	47.17	.250	1.47
8.00	7.50	2.87	C	47.17	.250	2.09
8.00	7.50	3.37	F	47.17	.250	2.59
8.00	7.50	4.00	F	47.17	.250	3.22
8.00	7.75	4.00	.025	48.70	.125*	3.41

x Standard (Tooling Available)  
\* Special Convolution width

Cylinder Bore DC	Piston Diameter DP	Height H	Sidewall Thickness Wsw	Effective Pressure Area Ae (in) <sup>2</sup>	Convolution C	Maximum Half Stroke SA/SB
8.00	7.50	4.50	F	47.17	.250	3.72
8.00	7.50	5.75	F	47.17	.250	4.97
8.00	7.50	6.75	F	47.17	.250	5.97
8.00	7.50	7.00	F	47.17	.250	6.22
8.00	7.75	7.86	F	48.70	.125*	7.27
8.25	7.25	2.12	F	47.17	.500*	.95
8.50	8.00	1.00	H	53.45	.250	.22
8.50	8.00	2.00	H	53.45	.250	1.22
8.50	8.00	3.00	H	53.45	.250	2.22
8.50	8.00	4.00	H	53.45	.250	3.22
8.50	8.00	5.00	H	53.45	.250	4.22
8.50	8.00	6.00	H	53.45	.250	5.22
8.50	8.00	7.00	H	53.45	.250	6.22
9.00	8.50	1.00	H	60.13	.250	.22
9.00	8.50	2.00	H	60.13	.250	1.22
9.00	8.50	3.00	H	60.13	.250	2.22
9.00	8.50	4.00	H	60.13	.250	3.22
9.00	8.50	5.00	H	60.13	.250	4.22
9.00	8.50	6.00	H	60.13	.250	5.22
9.00	8.25	7.00	H	58.42	.375*	6.02
9.50	9.00	1.00	H	67.20	.250	.22
9.50	9.00	2.00	H	67.20	.250	1.22
9.50	9.00	3.00	H	67.20	.250	2.22
9.50	9.00	4.00	H	67.20	.250	3.22
9.50	9.00	5.00	H	67.20	.250	4.22
9.50	9.00	6.50	H	67.20	.250	5.72
9.81	9.31	.72	F	71.48	.250	.01
10.00	9.50	1.00	H	74.66	.250	.22
10.00	9.25	1.50	H	72.75	.375*	.52
10.00	9.50	2.00	H	74.66	.250	1.22
10.00	9.50	2.25	.030	74.66	.250	1.47
10.00	9.50	3.00	H	74.66	.250	2.22
10.00	9.50	4.00	H	74.66	.250	3.22
10.00	9.25	5.00	H	72.45	.375*	4.02
10.00	9.25	5.00	.024	72.45	.375*	4.02
10.00	9.25	6.50	H	72.45	.375*	5.52
10.50	10.00	1.00	H	82.51	.250	.22
10.50	10.00	2.00	H	82.51	.250	1.22
10.50	10.00	3.00	H	82.51	.250	2.22
10.50	9.75	3.50	H	80.51	.375*	2.52
10.50	10.00	4.00	H	82.51	.250	3.22
10.50	10.00	5.00	H	82.51	.250	4.22
10.50	10.00	6.00	H	82.51	.250	5.22
10.62	10.12	2.35	H	84.45	.250	1.57
11.00	10.50	1.00	H	90.76	.250	.22
11.00	10.25	2.00	H	88.66	.375*	1.02
11.00	10.50	3.00	H	90.76	.250	2.22
11.00	10.50	4.00	H	90.76	.250	3.22
11.00	10.50	5.00	H	90.76	.250	4.22
11.00	10.50	6.00	H	90.76	.250	5.22
11.50	11.00	1.00	H	99.40	.250	.22
11.50	11.00	2.00	H	99.40	.250	1.22
11.50	11.00	3.00	H	99.40	.250	2.22
11.50	11.00	4.00	H	99.40	.250	3.22
11.50	11.00	5.00	H	99.40	.250	4.72
12.00	11.50	1.00	H	108.43	.250	.22
12.00	11.50	1.50	H	108.43	.250	.72
12.00	11.50	2.00	H	108.43	.250	1.22
12.00	11.50	2.14	F	108.43	.250	1.36
12.00	11.50	3.00	H	108.43	.250	2.22
12.00	11.50	4.00	H	108.43	.250	3.22
12.00	11.50	4.53	.042	108.43	.250	3.75
12.00	11.50	5.50	H	108.43	.250	4.72
12.00	11.50	6.00	D	108.43	.250	5.22
12.00	11.25	6.00	H	106.13	.375*	5.02
12.03	11.28	2.10	.040	106.68	.375*	1.12
12.17	11.72	1.78	F	112.06	.225*	1.03
13.50	13.00	3.00	F	137.88	.250	2.22
16.75	16.00	2.75	H	210.59	.375*	1.77
24.00	23.62	1.37	F	445.25	.190*	.68
24.37	23.62	3.25	.048	452.20	.375*	2.27

Side Wall Thickness D = approx. .024  
B = approx. .015  
F = approx. .035  
C = approx. .017  
H = approx. .045

**CLASS 4C DIAPHRAGMS**

**DESCRIPTION**

The Class 4C is similar to the Class 4 except that the convolution is molded in. The suggestions, pressures and other information, with regard to flange retention, listed under the "Description" of Class 4 (see page 7) also apply to the Class 4C.

Because it is molded in the "as-installed" configuration, the Class 4C diaphragm need not be inverted at installation. The pre-convoluted design has a small spring gradient or centering effect, which tends to return the diaphragm to its "as-molded" or neutral plane position. The design can be fastened to the piston with a flat retainer plate.

The stroke of these diaphragms is limited since deep-molded convolutions are impractical to manufacture.

**DIMENSIONS AND TOLERANCES**

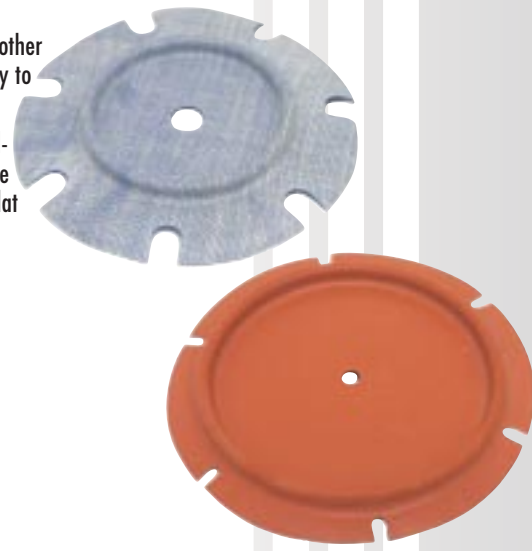
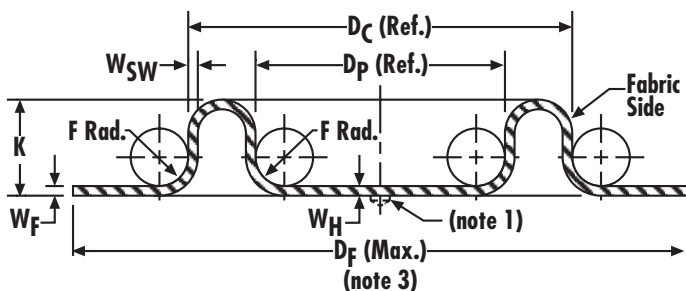

D <sub>C</sub>	.26 to .99	1.00 to 2.50	2.51 to 4.00	4.01 to 8.00	8.01 and up
K	As required to yield design stroke (See standard size tables & note #2)				
D <sub>C</sub> D <sub>p</sub>	Tolerances on D <sub>C</sub> and D <sub>p</sub> are ± .010" per inch of diameter but the tolerance will be no less than ±.010" or greater than ±.060"				
W <sub>H</sub> & W <sub>F</sub>	.020 ± .003	.020 ± .004	.030 ± .004	.035 ± .005	.045 ± .007
W <sub>SW</sub>	.015 ± .003 (Code "B")	.017 ± .003 (Code "C")	.024 ± .004 (Code "D")	.035 ± .005 (Code "F")	.045 ± .007 (Code "H")
F	1/32 R.	1/16 R.	3/32 R.	1/8 R.	1/8 R.
D <sub>F</sub>	DC + 3/4" See Note #3	DC + 1" See Note #3	DC + 1-1/2" See Note #3	DC + 2" See Note #3	DC + 2" See Note #3

- NOTES:
1. Stock diaphragms are supplied with a button on the pressure side. 1/8" diameter x 3/32" high on bore sizes 1" and over
  2. Height tolerances is ±.015
  3. Trim tolerances  
Hole Diameter OD Trim  
Diameter Tolerances  
0-1.00" ±.010"  
1.01-3.00" ±.015"  
over 3.01" ±.020
  4. Dimensions and tolerances pertain to Bellofram Rolling Diaphragms as manufactured and not to dimensions and tolerances of mating parts.

**CLASS 4C - STANDARD SIZES**

Cylinder Bore DC	Piston Diameter DP	Height K	Sidewall Thickness Wsw	Effective Pressure Area Ae (in) <sup>2</sup>	Convolution C	Maximum Half Stroke S <sub>a</sub> /S <sub>b</sub>
.26	.14	.07	.024	.03	.060	.01
.27	.12	.09	.020	.02	.075*	.04
.37	.25	.09	B	.07	.060	.05
x .37	.25	.10	B	.07	.060	.07
.37	.14	.10	.015	.05	.115*	.02
.37	.25	.12	.020	.07	.060	.11
.37	.25	.12	B	.07	.060	.11
.38	.25	.12	B	.07	.065	.11
.38	.26	.12	B	.08	.060	.11
.38	.24	.10	.020	.07	.070*	.01
.44	.31	.10	B	.11	.065	.07
.46	.28	.12	.017	.10	.090*	.05
.47	.27	.06	.010	.10	.100*	.01
x .50	.37	.10	B	.14	.065	.07
.50	.37	.11	.014	.14	.065	.08
.50	.31	.18	.028	.12	.095*	.20
.56	.44	.10	B	.19	.060	.07
.56	.44	.06	.013	.19	.060	.02
.58	.50	.07	.014	.22	.040*	.03
.58	.46	.10	.013	.21	.060	.07
.58	.46	.10	.022	.21	.060	.02
.61	.48	.10	.015	.23	.065	.05
.61	.48	.11	.023	.23	.065	.07
.62	.50	.07	.017	.24	.060	.01
x .62	.50	.10	B	.24	.060	.07
.69	.32	.21	B	.20	.185*	.17
.71	.58	.10	.016	.32	.065	.07

Cylinder Bore DC	Piston Diameter DP	Height K	Sidewall Thickness Wsw	Effective Pressure Area Ae (in) <sup>2</sup>	Convolution C	Maximum Half Stroke S <sub>a</sub> /S <sub>b</sub>
.71	.53	.13	.020	.30	.090*	.10
.75	.56	.07	.013	.33	.095*	.01
x .75	.62	.10	B	.36	.065	.07
.75	.57	.10	.015	.34	.090*	.04
.75	.56	.14	.020	.33	.095*	.12
.75	.31	.20	.017	.22	.220*	.16
.76	.49	.08	.014	.30	.135*	.01
.77	.59	.13	.015	.36	.090*	.10
.81	.69	.10	B	.44	.060	.07
.82	.58	.12	.022	.38	.120*	.05
x .87	.75	.10	B	.51	0.60	.07
.87	.63	.16	.018	.44	.120*	.13
.87	.75	.11	B	.51	.060	.09
.87	.75	.12	.018	.51	.060	.11
.94	.81	.10	B	.60	.065	.07
.96	.77	.10	.016	.58	.095*	.04
.96	.77	.13	.016	.58	.095*	.10
x 1.00	.81	.15	C	.64	.095	.08
1.00	.81	.15	.025	.64	.095	.08
1.00	.87	.07	.018	.68	.065*	.01
1.05	.89	.15	.012	.73	.080*	.10
1.06	.87	.15	C	.73	.095	.08
1.06	.75	.11	.017	.64	.155*	.01
1.07	.77	.12	B	.66	.150*	.02
x 1.12	.94	.15	C	.83	.090	.08
1.12	.62	.27	.015	.59	.250	.16

x Standard (Tooling Available)  
\* Special Convolution width

Side Wall Thickness D = approx. .024  
B = approx. .015  
F = approx. .035  
C = approx. .017  
H = approx. .045

Cylinder Bore DC	Piston Diameter DP	Height H	Sidewall Thickness Wsw	Effective Pressure Area Ae (in) <sup>2</sup>	Convolution C	Maximum Half Stroke SA/SB
1.12	.94	.17	C	.83	.090	.13
1.17	.90	.14	.012	.84	.135*	.02
1.19	.94	.15	.020	.89	1.25*	.05
1.19	1.00	.15	C	.94	.095	.08
1.21	1.08	.13	.013	1.02	.065*	.07
1.23	1.01	.12	.016	.98	.110*	.01
1.24	1.01	.12	.015	.99	.115*	.01
1.25	1.00	.12	.017	.99	.125*	.03
1.25	1.06	.12	C	1.04	.095	.02
x 1.25	1.06	.15	C	1.04	.095	.08
1.26	1.08	.19	.022	1.07	.090	.11
1.31	1.12	.15	C	1.15	.095	.08
1.34	1.16	.15	.018	1.22	.090	.08
1.35	.90	.15	.012	.99	.225*	.01
1.35	1.17	.19	.018	1.24	.090	.19
1.37	1.19	.12	D	1.28	.090	.02
x 1.37	1.19	.15	C	1.28	.090	.08
1.37	1.19	.12	C	1.28	.090	.02
1.37	1.19	.12	D	1.28	.090	.03
1.39	1.26	.19	.020	1.37	.095*	.13
1.41	1.09	.17	.011	1.22	.160*	.05
1.44	1.25	.15	C	1.42	.095	.08
1.45	1.00	.15	C	1.17	.225*	.01
1.48	1.19	.15	.021	1.39	.145	.04
1.49	1.13	.08	.017	1.34	.180	.01
1.50	1.28	.05	.015	1.51	.110*	.01
x 1.50	1.31	.15	C	1.55	.095	.08
1.50	.94	.16	.027	1.16	.280*	.01
1.50	1.00	.38	.011	1.22	.250*	.44
1.52	1.31	.09	.017	1.57	.105*	.01
1.52	.75	.64	.022	1.01	.385*	.77
1.56	1.37	.15	C	1.68	.095	.08
x 1.62	1.44	.15	C	1.83	.090	.08
1.64	1.24	.27	.017	1.62	.200*	.21
1.68	1.49	.11	.020	1.97	.095	.00
1.68	1.50	.15	C	1.98	.090	.08
1.68	1.50	.21	.017	1.98	.090	.20
x 1.75	1.56	.15	C	2.15	.095	.08
1.75	1.56	.17	.015	2.15	.095	.11
1.75	1.32	.20	.011	1.85	.215*	.06
1.76	1.26	.27	B	1.79	.250*	.16
1.78	1.59	.12	.014	2.22	.095	.02
1.78	1.59	.15	.017	2.22	.095	.08
1.83	1.37	.31	.020	2.01	.230*	.26
1.87	1.69	.15	C	2.48	.090	.08
1.87	1.63	.18	.014	2.40	.120*	.16
x 2.00	1.81	.15	C	2.85	.095	.08
2.00	1.81	.15	.025	2.85	.095	.08
2.00	1.49	.26	.017	2.39	.255*	.14
2.00	1.69	.22	.015	2.67	.155*	.16
2.00	1.50	.28	.016	2.40	.250*	.18
2.01	1.64	.18	C	2.61	.185*	.05
2.04	1.86	.14	.015	2.98	.090	.06
2.04	1.85	.15	C	2.97	.095	.08
2.04	1.85	.17	.018	2.97	.095	.11
2.05	1.85	.14	.020	2.98	.100*	.05
2.06	1.84	.12	.016	2.98	.110*	.01
2.07	1.85	.12	.015	3.01	.110*	.01
2.12	1.94	.15	C	3.23	.090	.08
2.12	1.87	.10	.015	3.12	.125*	.02
2.12	1.94	.13	.016	3.23	.090	.05

x Standard (Tooling Available)  
\* Special Convolution width

Cylinder Bore DC	Piston Diameter DP	Height H	Sidewall Thickness Wsw	Effective Pressure Area Ae (in) <sup>2</sup>	Convolution C	Maximum Half Stroke SA/SB
2.14	1.92	.16	.014	3.23	.110*	.08
x 2.25	2.06	.15	C	3.64	.095	.08
2.31	2.12	.12	.017	3.85	.095	.02
2.33	2.05	.09	.018	3.76	.140*	.01
2.35	2.15	.10	.022	3.97	.100*	.01
2.37	2.19	.15	C	4.08	.090	.08
2.46	2.31	.05	.017	4.46	.075*	.01
2.50	2.31	.15	.020	4.54	.095	.08
x 2.50	2.31	.15	C	4.54	.095	.08
2.68	2.37	.25	C	5.00	.155	.15
x 2.75	2.44	.25	D	5.28	.155	.15
2.87	2.56	.25	D	5.78	.155	.15
3.00	2.69	.15	C	6.35	.155	.01
x 3.00	2.69	.25	D	6.35	.155	.15
3.00	2.31	.10	.022	5.53	.345*	.01
3.00	2.60	.13	.011	6.15	.200*	.01
3.12	2.75	.15	.024	6.76	.185*	.01
3.12	2.87	.18	.015	7.04	.125*	.04
3.12	2.81	.25	.024	6.90	.155	.15
3.12	2.81	.25	D	6.90	.155	.15
3.20	2.99	.12	.016	7.52	.105*	.03
3.20	2.58	.14	.012	6.55	.310*	.01
x 3.25	2.94	.25	D	7.52	.155	.15
3.37	3.06	.25	D	8.11	.155	.15
3.37	2.37	.44	F	6.46	.500*	.19
3.38	2.34	.50	.090	6.42	.520*	.23
3.50	3.19	.25	.024	8.78	.155	.15
x 3.50	3.19	.25	D	8.78	.155	.15
3.58	3.00	.25	.015	8.50	.290*	.02
3.62	3.31	.25	D	9.42	.155	.15
x 3.75	3.44	.25	D	10.15	.155	.15
3.87	3.56	.25	D	10.83	.155	.15
x 4.00	3.69	.25	D	11.61	.155	.15
4.00	3.69	.25	B	11.61	.155	.15
4.12	3.94	.16	C	12.75	.090*	.01
x 4.25	3.75	.37	F	12.56	.250	.24
x 4.50	4.00	.37	F	14.18	.250	.24
4.75	4.25	.37	F	15.90	.250	.24
4.80	4.05	.40	.022	15.37	.375*	.17
x 5.00	4.50	.37	F	17.72	.250	.24
5.50	5.00	.25	F	21.64	.250	.01
x 5.50	5.00	.37	F	21.64	.250	.24
x 5.75	5.25	.37	F	23.75	.250	.24
6.00	5.69	.25	F	26.83	.155*	.09
x 6.00	5.50	.37	F	25.96	.250	.24
x 6.50	6.00	.37	F	30.67	.250	.24
x 7.00	6.50	.37	F	35.78	.250	.24
x 7.50	7.00	.37	F	41.28	.250	.24
7.75	7.25	.37	F	44.17	.250	.24
x 8.00	7.50	.37	F	47.17	.250	.24
8.50	8.00	.50	H	53.45	.250	.50
9.00	8.50	.50	H	60.13	.250	.50
9.50	9.00	.50	H	67.20	.250	.50
10.00	9.50	.50	H	74.66	.250	.50
10.00	9.62	.37	F	75.58	.190*	.30
10.50	10.00	.50	H	82.51	.250	.50
11.00	10.50	.50	H	90.76	.250	.50
11.50	11.00	.50	H	99.40	.250	.50
12.00	11.50	.50	H	108.43	.250	.50

Side Wall Thickness B = approx. .015 C = approx. .017  
D = approx. .024 F = approx. .035 H = approx. .045



## CLASS 3 DIAPHRAGMS

### DESCRIPTION

Class 3 Bellofram Rolling Diaphragms employ a bead-flange. The flange is similar to an "O"-Ring and seals the diaphragm via axial compression of the "D" shaped bead.

The bead is installed in a housing having a mating groove. This design eliminates the need for any perforations in the diaphragm flange, since it is retained by squeezing the bead into its mating groove.

Because the "D" shaped bead loses some of its effectiveness at high pressures as a result of sidewall stress, this design is not recommended where differential pressures exceed 150 psi.

The convolution is formed by inverting the top head corner radius around its entire periphery during installation. To insure that the piston corner radius does not return to its "as-molded" shape, a curved lip retainer plate is generally recommended.

### NOTES:

1. Stock diaphragms are supplied with a button on the pressure side. 1/8" diameter x 3/32" high on bore sizes 1" and over
2. The radius is not the piston radius since the head corner will be inverted at assembly.
3. Height should not exceed the bore (D<sub>C</sub>). Tolerance on height to be no less than ±.015" per inch of height.
4. This "V" rib is for diaphragm processing only. It may not appear on all diaphragms. It is not functional and need not be completely filled. Rib is normally on rubber side of diaphragm.
5. Two "V" ribs may be used on beads that are .25 or larger in width.
6. Number, size, spacing and location of "V" ribs may be modified to suit specific beads, or may be left off altogether.
7. Trim tolerances:  

Hole Diameter	OD Trim	Tolerances
0-1.00"	Diameter	±.010"
1.01 - 3.00"		±.015"
over 3.00"		±.020"

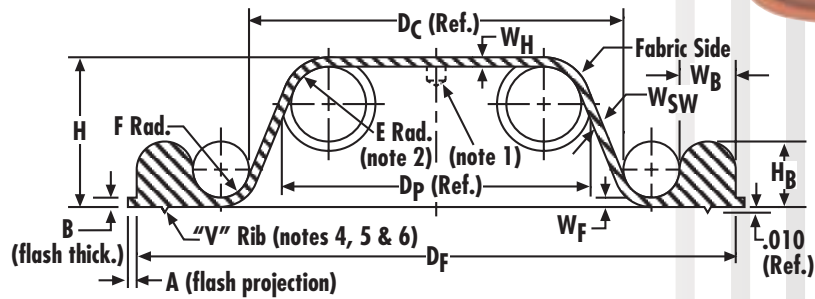

Diaphragms are shown in the "as molded" configuration. The diaphragm must be inverted prior to installation.

D <sub>C</sub>	.37 to .99	1.00 to 2.50	2.51 to 4.00	4.01 to 8.00	8.01 and up
H	As required to yield design stroke (See standard size tables & note #3)				
D <sub>C</sub>	Tolerances on D <sub>C</sub> and D <sub>p</sub> are ± .010" per inch of diameter but the tolerance will be no less than ±.010" or greater than ±.060"				
D <sub>p</sub>					
W <sub>H</sub> & W <sub>F</sub>	.020 ± .005	.020 ± .005	.030 ± .005	.035 ± .005	.045 ± .007
W <sub>SW</sub>	.015 ± .003 (Code "B")	.017 ± .003 (Code "C")	.024 ± .004 (Code "D")	.035 ± .005 (Code "F")	.045 ± .007 (Code "H")
A	.025 Max.	.025 Max.	.035 Max.	.040 Max.	.056 Max.
B	.025 Max.	.025 Max.	.035 Max.	.040 Max.	.056 Max.
E	3/32 R.	1/8 R.	5/32 R.	1/4 R.	1/4 R.
F	1/32 R.	1/16 R.	3/32 R.	1/8 R.	1/8 R.
D <sub>F</sub>	D <sub>C</sub> + 5/16"	D <sub>C</sub> + 1/2"	D <sub>C</sub> + 3/4"	D <sub>C</sub> + 1"	D <sub>C</sub> + 1"
W <sub>B</sub>	.094 ± .003	.125 ± .003	.187 ± .003	.250 ± .003	.250 ± .004
H <sub>B</sub>	.095 ± .004	.135 ± .004	.200 ± .005	.270 ± .007	.270 ± .008

8. Dimensions and tolerances pertain to Bellofram Rolling diaphragms as manufactured and not to dimensions and tolerances of mating parts.

## CLASS 3 - STANDARD SIZES

Cylinder Bore DC	Piston Diameter DP	Height H	Sidewall Thickness Wsw	Effective Pressure Area Ae (in) <sup>2</sup>	Convolution C	Maximum Half Stroke SA/SB
x .37	.25	.31	B	.07	.060	.09
.44	.31	.31	B	.11	.065	.08
.44	.31	.44	B	.11	.065	.21
.44	.31	.31	C	.11	.065	.08
x .50	.37	.38	B	.14	.065	.15
.56	.44	.44	B	.19	.060	.22
.62	.50	.37	C	.24	.060	.15
x .62	.50	.50	B	.24	.060	.28
.69	.56	.56	B	.30	.065	.33
.69	.48	.77	C	.26	.105*	.48
.75	.65	.32	.015	.38	.050*	.12
x .75	.62	.62	B	.36	.065	.39
.75	.62	.75	B	.36	.065	.52
.81	.68	.62	B	.44	.062	.40
.81	.69	.69	C	.44	.060	.47
.82	.73	.33	.015	.47	.045*	.13
.87	.75	.32	B	.51	.060	.10
.87	.75	.34	.015	.51	.060	.12
x .87	.75	.75	B	.51	.060	.53
.87	.75	.87	B	.51	.062	.71
.94	.81	.62	B	.60	.065	.39
.94	.81	.81	B	.60	.065	.58
x 1.00	.81	.44	C	.64	.095	.06
x 1.00	.81	.62	C	.64	.095	.24
1.00	.81	.75	C	.64	.095	.37
x 1.00	.81	.81	C	.64	.095	.43
x 1.00	.81	1.00	C	.64	.095	.62
1.06	.87	.44	C	.73	.095	.06
1.06	.87	.62	C	.73	.095	.24
1.06	.87	.67	.018	.73	.095	.29
1.06	.87	.67	C	.73	.095	.49

x Standard (Tooling Available)  
 \* Special Convolution width

Cylinder Bore DC	Piston Diameter DP	Height H	Sidewall Thickness Wsw	Effective Pressure Area Ae (in) <sup>2</sup>	Convolution C	Maximum Half Stroke SA/SB
1.06	.87	1.06	C	.73	.095	.68
x 1.12	.94	.44	C	.83	.090	.07
x 1.12	.94	.69	C	.83	.090	.32
.44	.31	.31	C	.11	.065	.08
x 1.12	.94	.80	.011	.59	.250*	.18
x 1.12	.94	.94	C	.83	.090	.57
1.12	.94	1.12	.010	.83	.090	.75
x 1.12	.94	1.12	C	.83	.090	.75
1.19	1.00	.44	C	.94	.095	.06
1.19	1.00	.50	C	.94	.095	.22
1.19	1.00	1.00	C	.94	.095	.62
1.19	1.00	1.19	C	.94	.095	.81
1.25	1.06	.44	C	1.04	.095	.06
x 1.25	1.06	.50	C	1.04	.095	.12
1.25	1.06	.68	C	1.04	.095	.30
x 1.25	1.06	.75	C	1.04	.095	.37
x 1.25	1.06	1.00	C	1.04	.095	.62
x 1.25	1.06	1.25	C	1.04	.095	.87
1.31	1.12	.44	C	1.15	.095	.06
1.31	1.12	.56	C	1.15	.095	.18
1.31	1.12	.81	C	1.15	.095	.43
1.31	1.12	1.06	C	1.15	.095	.68
1.31	1.12	1.31	C	1.15	.095	.93
x 1.37	1.19	.44	C	1.28	.090	.07
1.37	1.16	.56	C	1.25	.105*	.17
x 1.37	1.19	.56	C	1.28	.090	.19
x 1.37	1.19	.87	C	1.28	.090	.50
x 1.37	1.19	1.12	C	1.28	.090	.75
x 1.37	1.19	1.37	C	1.28	.090	1.00
1.44	1.25	.44	C	1.42	.095	.06
1.44	1.25	.62	C	1.42	.095	.24
1.44	1.25	.94	C	1.42	.095	.56

Side Wall Thickness D = approx. .024 B = approx. .015 F = approx. .035 C = approx. .017 H = approx. .045

# 16 Bellofram

ORIGINATOR OF THE ROLLING DIAPHRAGM

Cylinder Bore DC	Piston Diameter DP	Height H	Sidewall Thickness Wsw	Effective Pressure Area Ae (in) <sup>2</sup>	Convolution C	Maximum Half Stroke SA/SB
1.44	1.25	1.00	C	1.42	.095	.62
1.44	1.25	1.19	C	1.42	.095	.81
1.44	1.25	1.44	C	1.42	.095	1.06
x 1.50	1.31	.44	C	1.55	.095	.06
1.50	1.31	.60	C	1.55	.095	.22
1.50	1.26	.62	.016	1.49	.120*	.20
x 1.50	1.31	.62	C	1.55	.095	.24
x 1.50	1.31	.94	C	1.55	.095	.56
1.50	1.29	.94	.021	1.52	.105*	.55
1.50	1.31	1.25	C	1.55	.095	.87
x 1.50	1.31	1.50	C	1.55	.095	1.12
1.56	1.37	.44	C	1.68	.095	.06
1.56	1.37	.69	C	1.68	.095	.31
1.56	1.37	1.00	C	1.68	.095	.62
1.56	1.37	1.31	C	1.68	.095	.93
1.56	1.37	1.56	C	1.68	.095	1.18
x 1.62	1.44	.44	C	1.83	.090	.07
x 1.62	1.44	.69	C	1.83	.090	.32
x 1.62	1.44	1.00	C	1.83	.090	.63
x 1.62	1.44	1.37	C	1.83	.090	1.00
x 1.62	1.44	1.62	C	1.83	.090	1.25
1.68	1.50	.44	C	1.98	.090	.07
1.68	1.50	.75	C	1.98	.090	.38
1.68	1.50	1.06	C	1.98	.090	.69
1.68	1.50	1.44	C	1.98	.090	1.07
1.68	1.50	1.68	C	1.98	.090	1.31
1.75	1.56	.44	B	2.15	.095	.06
x 1.75	1.56	.44	C	2.15	.095	.06
x 1.75	1.56	.75	C	2.15	.095	.37
x 1.75	1.56	1.06	C	2.15	.095	.68
x 1.75	1.56	1.44	C	2.15	.095	1.06
x 1.75	1.56	1.75	C	2.15	.095	1.37
1.76	1.26	.80	.011	1.79	.250*	.18
1.87	1.69	.44	C	2.48	.090	.07
1.87	1.69	.75	C	2.48	.090	.38
1.87	1.69	.81	C	2.48	.090	.44
1.87	1.69	1.12	C	2.48	.090	.75
1.87	1.69	1.44	C	2.48	.090	1.07
1.87	1.69	1.50	C	2.48	.090	1.13
1.87	1.69	1.87	C	2.48	.090	1.50
1.94	1.75	1.21	C	2.67	.095	.83
x 2.00	1.81	.44	C	2.85	.095	.06
2.00	1.81	.62	C	2.85	.095	.24
x 2.00	1.81	.81	C	2.85	.095	.43
2.00	1.81	1.00	C	2.85	.095	.62
x 2.00	1.81	1.25	C	2.85	.095	.87
2.00	1.69	1.62	.020	2.67	.155*	1.15
x 2.00	1.81	1.62	C	2.85	.095	1.24
x 2.00	1.81	2.00	C	2.85	.095	1.62
2.00	1.62	2.00	F	2.57	.190*	1.47
2.08	1.89	1.03	.016	3.09	.095	.65
2.12	1.94	.62	C	3.23	.090	.25
2.12	1.62	.69	C	2.74	.250*	.07
2.12	1.94	.87	C	3.23	.090	.50
2.12	1.94	1.31	C	3.23	.090	.94
2.12	1.94	1.75	C	3.23	.090	1.38
2.12	1.94	2.12	C	3.23	.090	1.75
2.19	2.00	1.00	C	3.44	.095	.62
2.25	2.06	.45	.016	3.64	.095	.07
x 2.25	2.06	.62	C	3.64	.095	.24
x 2.25	2.06	.94	C	3.64	.095	.56
x 2.25	2.06	1.37	C	3.64	.095	.99
x 2.25	2.06	1.81	C	3.64	.095	1.43
x 2.25	2.06	2.25	C	3.64	.095	1.87
2.37	2.19	.62	C	4.08	.090	.25
2.37	2.19	1.00	C	4.08	.090	.63
2.37	2.19	1.10	C	4.08	.090	.73
2.37	2.19	1.44	C	4.08	.090	1.07
2.37	2.19	1.87	C	4.08	.090	1.50
2.37	2.19	2.37	C	4.08	.090	2.00
2.39	2.17	2.40	.023	4.08	.110*	2.00
2.44	1.94	1.62	.032	3.76	.250*	1.01
2.50	2.31	.44	C	4.54	.095	.06
2.50	2.31	.62	C	4.54	.095	.24
2.50	2.31	.87	C	4.54	.094	.50
x 2.50	2.31	1.06	C	4.54	.095	.68
2.50	2.31	1.50	.020	4.54	.095	1.12
2.50	2.31	1.50	D	4.54	.095	1.12
2.50	2.31	1.50	C	4.54	.095	1.12
x 2.50	2.31	2.00	C	4.54	.095	1.62
x 2.50	2.31	2.50	C	4.54	.095	2.12
2.62	2.31	.87	D	4.77	.155	.32
2.62	2.31	1.00	D	4.77	.155	.45
2.62	2.31	1.06	D	4.77	.155	.51

x Standard (Tooling Available)  
\* Special Convolution Width

Cylinder Bore DC	Piston Diameter DP	Height H	Sidewall Thickness Wsw	Effective Pressure Area Ae (in) <sup>2</sup>	Convolution C	Maximum Half Stroke SA/SB
2.62	2.31	1.56	D	4.77	.155	1.01
2.62	2.31	2.12	D	4.77	.155	1.57
2.62	2.31	2.62	D	4.77	.155	2.07
x 2.75	2.44	1.12	D	5.28	.155	.57
x 2.75	2.44	1.62	D	5.28	.155	1.07
x 2.75	2.44	2.25	D	5.28	.155	1.70
x 2.75	2.44	2.75	D	5.28	.155	2.20
2.87	2.56	1.12	D	5.78	.155	.57
2.87	2.56	1.69	D	5.78	.155	1.14
2.87	2.56	2.31	D	5.78	.155	1.76
2.87	2.56	2.87	D	5.78	.155	2.32
3.00	2.69	1.00	.016	6.35	.155	.45
x 3.00	2.69	1.19	D	6.35	.155	.64
3.00	2.63	1.25	.012	6.22	.185*	.65
x 3.00	2.69	1.75	D	6.35	.155	1.20
x 3.00	2.69	2.37	D	6.35	.155	1.82
x 3.00	2.69	3.00	D	6.35	.155	2.45
3.12	2.81	1.25	D	6.90	.155	.70
3.12	2.81	1.87	D	6.90	.155	1.32
3.12	2.81	2.50	D	6.90	.155	1.95
3.12	2.81	3.12	D	6.90	.155	2.57
3.25	2.94	1.31	D	7.52	.155	.76
x 3.25	2.94	1.94	D	7.52	.155	1.39
3.25	2.94	2.62	D	7.52	.155	2.07
3.25	2.94	2.62	F	7.52	.155	2.07
3.25	2.25	3.12	F	5.93	.500*	2.03
3.37	3.06	2.00	D	8.11	.155	1.45
3.37	3.06	2.75	D	8.11	.155	2.20
3.37	3.06	3.00	D	8.11	.155	2.45
3.37	3.06	3.22	D	8.11	.155	2.67
3.37	3.06	3.37	D	8.11	.155	2.82
3.50	3.19	1.00	.017	8.78	.155	.45
x 3.50	3.19	1.00	D	8.78	.155	.45
3.50	3.19	1.25	D	8.78	.155	.70
3.50	3.19	1.44	D	8.78	.155	.89
3.50	3.19	1.50	D	8.78	.155	.95
x 3.50	3.19	2.12	D	8.78	.155	1.57
3.50	3.19	2.81	D	8.78	.155	2.26
x 3.50	3.19	3.50	D	8.78	.155	2.95
3.62	3.31	1.00	D	9.42	.155	.45
3.62	3.31	1.50	D	9.42	.155	.95
3.62	3.31	2.19	D	9.42	.155	1.64
3.62	3.31	2.87	D	9.42	.155	2.32
3.62	3.31	3.62	D	9.42	.155	3.07
x 3.75	3.44	1.00	D	10.15	.155	.45
3.75	3.44	1.25	D	10.15	.155	.70
3.75	3.44	1.50	D	10.15	.155	.95
3.75	3.25	2.25	.030	9.62	.250*	1.55
x 3.75	3.44	2.25	D	10.15	.155	1.70
3.75	3.44	3.00	D	10.15	.155	2.45
x 3.75	3.44	3.75	D	10.15	.155	3.20
3.87	3.56	1.00	D	10.83	.155	.45
3.87	3.56	1.56	D	10.83	.155	1.01
3.87	3.56	2.37	D	10.83	.155	1.82
3.87	3.56	3.12	D	10.83	.155	2.57
3.87	3.56	3.87	D	10.83	.155	3.32
x 4.00	3.69	1.00	D	11.61	.155	.45
4.00	3.69	1.37	D	11.61	.155	.82
4.00	3.69	1.62	D	11.61	.155	1.07
4.00	3.69	2.03	D	11.61	.155	1.48
x 4.00	3.69	2.44	D	11.61	.155	1.89
4.00	3.69	3.25	D	11.61	.155	2.70
x 4.00	3.69	4.00	D	11.61	.155	3.45
4.12	3.62	1.00	F	11.76	.250	.22
4.12	3.62	1.62	F	11.76	.250	.84
4.12	3.62	2.50	F	11.76	.250	1.72
4.12	3.62	3.31	F	11.76	.250	2.53
4.12	3.62	4.12	F	11.76	.250	3.34
4.25	3.75	1.00	F	12.56	.250	.22
4.25	3.75	1.37	F	12.56	.250	.59
4.25	3.75	1.69	F	12.56	.250	.91
4.25	3.75	2.62	F	12.56	.250	1.84
4.25	3.75	3.37	F	12.56	.250	2.59
4.25	3.75	4.25	F	12.56	.250	3.47
4.37	3.87	1.00	F	13.33	.250	.22
4.37	3.87	1.69	F	13.33	.250	.91
4.37	3.87	2.69	F	13.33	.250	1.91
4.37	3.87	3.50	F	13.33	.250	2.72
4.37	3.87	4.37	F	13.33	.250	3.59
x 4.50	4.00	1.00	F	14.18	.250	.22
4.50	4.00	1.23	F	14.18	.250	.45
4.50	4.00	1.50	F	14.18	.250	.72
4.50	4.00	1.81	F	14.18	.250	1.03
x 4.50	4.00	2.75	F	14.18	.250	1.97

Side Wall Thickness D = approx. .024  
B = approx. .015  
C = approx. .017  
F = approx. .035  
H = approx. .045

Cylinder Bore DC	Piston Diameter DP	Height H	Sidewall Thickness Wsw	Effective Pressure Area Ae (in) <sup>2</sup>	Convolution C	Maximum Half Stroke SA/SB
4.50	4.00	3.62	F	14.18	.250	2.84
x 4.50	4.00	4.50	F	14.18	.250	3.72
4.62	4.12	1.00	F	14.99	.250	.22
4.62	4.12	2.81	F	14.99	.250	2.03
4.62	4.12	3.69	F	14.99	.250	2.91
4.75	4.25	1.87	F	15.90	.250	1.09
4.75	4.25	1.50	F	15.90	.250	.72
4.75	4.25	2.87	F	15.90	.250	2.09
4.75	4.25	3.75	F	15.90	.250	2.97
4.75	4.25	4.75	F	15.90	.250	3.97
4.87	4.37	1.00	F	16.76	.250	.22
4.87	4.37	1.87	F	16.76	.250	1.09
4.87	4.37	2.94	F	16.76	.250	2.16
4.87	4.37	3.87	F	16.76	.250	3.09
x 5.00	4.50	1.00	F	17.72	.250	.22
5.00	4.50	2.00	F	17.72	.250	1.22
x 5.00	4.50	3.00	F	17.72	.250	2.22
5.00	4.50	4.00	F	17.72	.250	3.22
x 5.00	4.50	5.00	F	17.72	.250	4.22
5.12	4.62	1.12	F	18.62	.250	.34
5.12	4.62	2.00	F	18.62	.250	1.22
5.12	4.62	3.12	F	18.62	.250	2.34
5.12	4.62	4.12	F	18.62	.250	3.34
5.12	4.62	5.12	F	18.62	.250	4.34
5.25	4.75	1.12	F	19.63	.250	.34
5.25	4.75	1.62	F	19.63	.250	.84
5.25	4.75	2.12	F	19.63	.250	1.34
5.25	4.75	3.19	F	19.63	.250	2.41
5.25	4.75	4.25	F	19.63	.250	3.47
5.25	4.75	5.25	F	19.63	.250	4.47
5.37	4.87	1.12	F	20.58	.250	.34
5.37	4.87	2.12	F	20.58	.250	1.34
5.37	4.87	3.31	F	20.58	.250	2.53
5.37	4.87	4.37	F	20.58	.250	3.59
5.37	4.87	5.37	F	20.58	.250	4.59
5.50	5.00	1.00	F	21.64	.250	.22
x 5.50	5.00	1.12	F	21.64	.250	.34
5.50	5.00	1.75	F	21.64	.250	.97
5.50	5.00	2.25	F	21.64	.250	1.47
x 5.50	5.00	3.37	F	21.64	.250	2.59
5.50	5.00	4.44	F	21.64	.250	3.66
x 5.50	5.00	5.50	F	21.64	.250	4.72
5.62	5.12	1.12	F	22.64	.250	.34
5.62	5.12	2.25	F	22.64	.250	1.47
5.62	5.12	3.44	F	22.64	.250	2.66
5.62	5.12	4.50	F	22.64	.250	3.72
5.62	5.12	5.62	F	22.64	.250	4.84
5.75	5.25	1.25	F	23.75	.250	.47
5.75	5.25	1.87	F	23.75	.250	1.09
5.75	5.25	2.37	F	23.75	.250	1.59
5.75	5.25	3.50	F	23.75	.250	2.72
5.75	5.25	4.56	F	23.75	.250	3.78
5.75	5.25	5.75	F	23.75	.250	4.97
5.87	5.37	1.25	F	24.80	.250	.47
5.87	5.37	2.37	F	24.80	.250	1.59
5.87	5.37	3.56	F	24.80	.250	2.78
5.87	5.37	4.75	F	24.80	.250	3.97
5.87	5.37	5.87	F	24.80	.250	5.09
6.00	5.50	1.00	F	25.96	.250	.22
x 6.00	5.50	1.25	F	25.96	.250	.47
6.00	5.50	1.87	F	25.96	.250	1.09
6.00	5.50	2.50	F	25.96	.250	1.72
x 6.00	5.50	3.62	F	25.96	.250	2.84
6.00	5.50	4.81	F	25.96	.250	4.03
x 6.00	5.50	6.00	F	25.96	.250	5.22
6.25	5.75	1.50	F	28.27	.250	.72
6.25	5.75	2.75	F	28.27	.250	1.97
6.25	5.75	4.00	F	28.27	.250	3.22
6.25	5.75	5.00	F	28.27	.250	4.22
6.25	5.75	6.25	F	28.27	.250	5.47
6.50	6.00	1.00	F	30.67	.250	.22
6.50	6.00	1.50	F	30.67	.250	.72
6.50	6.00	2.25	F	30.67	.250	1.47
6.50	6.00	3.00	F	30.67	.250	2.22
6.50	6.00	4.25	F	30.67	.250	3.47
6.50	6.00	5.25	F	30.67	.250	4.47
6.50	6.00	6.50	F	30.67	.250	5.72
6.75	6.25	1.75	F	33.18	.250	.97
6.75	6.25	3.25	F	33.18	.250	2.47
6.75	6.25	4.50	F	33.18	.250	3.72
6.75	6.25	5.50	F	33.18	.250	4.72
6.75	6.25	6.75	F	33.18	.250	5.97

Cylinder Bore DC	Piston Diameter DP	Height H	Sidewall Thickness Wsw	Effective Pressure Area Ae (in) <sup>2</sup>	Convolution C	Maximum Half Stroke SA/SB
7.00	6.50	1.00	F	35.78	.250	.22
7.00	6.50	1.75	F	35.78	.250	.97
7.00	6.50	2.62	F	35.78	.250	1.84
7.00	6.50	3.00	.035	35.78	.250	2.22
7.00	6.50	3.50	F	35.78	.250	2.72
7.00	6.50	4.75	F	35.78	.250	3.97
7.00	6.50	5.75	F	35.78	.250	4.97
7.25	6.75	2.00	F	38.48	.250	1.22
7.25	6.75	3.75	F	38.48	.250	2.97
7.25	6.75	5.00	F	38.48	.250	4.22
7.25	6.75	6.00	F	38.48	.250	5.22
7.50	7.00	1.00	F	41.28	.250	.22
7.50	7.00	1.50	F	41.28	.250	.72
7.50	7.00	2.00	F	41.28	.250	1.22
7.50	7.00	3.00	F	41.28	.250	2.22
7.50	7.00	4.00	F	41.28	.250	3.22
7.50	7.00	5.25	F	41.28	.250	4.47
7.50	7.00	6.25	F	41.28	.250	5.47
7.75	7.25	2.25	F	44.17	.250	1.47
7.75	7.25	4.25	F	44.17	.250	3.47
7.75	7.25	5.50	F	44.17	.250	4.72
7.75	7.25	6.50	F	44.17	.250	5.72
8.00	7.50	1.00	F	47.17	.250	.22
8.00	7.50	1.50	F	47.17	.250	.72
8.00	7.50	2.00	F	47.17	.250	1.22
8.00	7.50	2.25	F	47.17	.250	1.47
8.00	7.50	3.37	F	47.17	.250	2.59
8.00	7.50	4.50	F	47.17	.250	3.72
8.00	7.50	5.75	F	47.17	.250	4.97
8.00	7.50	6.75	F	47.17	.250	5.97
8.37	7.87	3.38	.034	51.84	.250	2.60
8.50	8.00	1.00	H	53.45	.250	.22
8.50	8.00	2.00	H	53.45	.250	1.22
8.50	8.00	3.00	H	53.45	.250	2.22
8.50	8.00	4.00	H	53.45	.250	3.22
8.50	8.00	5.00	H	53.45	.250	4.22
8.50	8.00	6.00	H	53.45	.250	5.22
8.50	8.00	7.00	H	53.45	.250	6.22
9.00	8.50	1.00	H	60.13	.250	.22
9.00	8.50	2.00	H	60.13	.250	1.22
9.00	8.50	3.00	H	60.13	.250	2.22
9.00	8.50	4.00	H	60.13	.250	3.22
9.00	8.50	5.00	H	60.13	.250	4.22
9.00	8.50	6.00	H	60.13	.250	5.22
9.00	8.50	7.00	H	60.13	.250	6.22
9.50	9.00	1.00	H	67.20	.250	.22
9.50	9.00	2.00	H	67.20	.250	1.22
9.50	9.00	3.00	H	67.20	.250	2.22
9.50	8.75	4.00	H	65.39	.375*	2.02
9.50	9.00	5.00	H	67.20	.250	3.22
9.50	9.00	6.00	H	67.20	.250	4.22
9.50	9.00	7.00	H	67.20	.250	5.22
10.00	9.50	1.00	H	74.66	.250	.22
10.00	9.50	2.00	H	74.66	.250	1.22
10.00	9.50	3.00	H	74.66	.250	2.22
10.00	9.50	4.00	H	74.66	.250	3.22
10.00	9.50	5.00	H	74.66	.250	4.22
10.00	9.50	6.50	H	74.66	.250	5.72
10.50	10.00	1.00	H	82.51	.250	.22
10.50	10.00	2.00	H	82.51	.250	1.22
10.50	10.00	3.00	H	82.51	.250	2.22
10.50	10.00	4.00	H	82.51	.250	3.22
10.50	10.00	5.00	H	82.51	.250	4.22
10.50	10.00	6.00	H	82.51	.250	5.22
11.00	10.50	1.00	H	90.76	.250	.22
11.00	10.50	2.00	H	90.76	.250	1.22
11.00	10.50	3.00	H	90.76	.250	2.22
11.00	10.50	4.00	H	90.76	.250	3.22
11.00	10.50	5.00	H	90.76	.250	4.22
11.50	11.00	1.00	H	99.40	.250	.22
11.50	11.00	2.00	H	99.40	.250	1.22
11.50	11.00	3.00	H	99.40	.250	2.22
11.50	11.00	4.00	H	99.40	.250	3.22
12.00	11.50	1.00	H	108.43	.250	.22
12.00	11.50	2.00	H	108.43	.250	1.22
12.00	11.50	3.00	H	108.43	.250	2.22
12.00	11.25	3.00	H	106.13	.375*	2.02
12.00	11.73	3.25	.050	110.56	.135*	2.64
12.00	11.50	4.00	H	108.43	.250	3.22
12.00	11.50	5.50	H	108.43	.250	4.72

x Standard (Tooling Available)  
\* Special Convolution width

Side Wall Thickness D = approx. .024  
B = approx. .015 F = approx. .035  
C = approx. .017 H = approx. .045



## CLASS 3C DIAPHRAGMS

### DESCRIPTION

The Class 3C diaphragm has characteristics similar to the Class 3 except the convolution is molded in. The information concerning flange design described for Class 3 also applies to Class 3C diaphragms.

Since this diaphragm is made in the "as-installed" shape with a permanent convolution it does not require inversion at assembly. It has a small centering force which may tend to return the diaphragm to its "as-molded" or neutral plane position. Because no inversion is required, only a flat retainer plate is needed to retain the head of the diaphragm to the piston.

The stroke of the Class 3 C design is limited since deep molded convolutions are presently impractical to manufacture. It is recommended this design be used where differential pressures do not exceed 150 psi.

### DIMENSIONS AND TOLERANCES

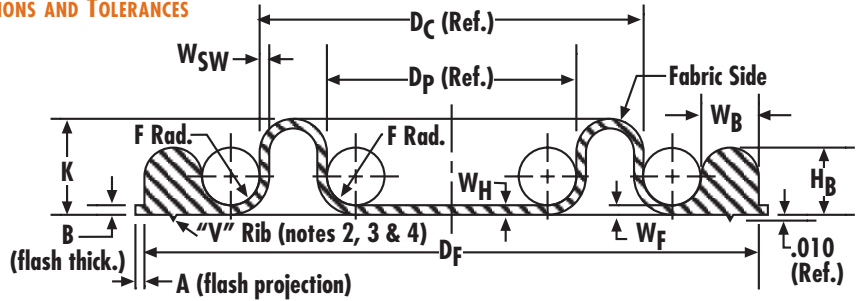

D <sub>C</sub>	.37 to .99	1.00 to 2.50	2.51 to 4.00	4.01 to 8.00	8.01 and up
K	As required to yield design stroke (See standard size tables & note #1)				
D <sub>C</sub> D <sub>p</sub>	Tolerances on D <sub>C</sub> and D <sub>p</sub> are ± .010" per inch of diameter but the tolerance will be no less than ±.010" or greater than ±.060"				
W <sub>H</sub> & W <sub>F</sub>	.020 ± .003	.020 ± .004	.030 ± .004	.035 ± .005	.045 ± .007
W <sub>SW</sub>	.015 ± .003 (Code "B")	.017 ± .003 (Code "C")	.024 ± .004 (Code "D")	.035 ± .005 (Code "F")	.045 ± .007 (Code "H")
A	.025 Max.	.025 Max.	.035 Max.	.040 Max.	.056 Max.
B	.025 Max.	.025 Max.	.035 Max.	.040 Max.	.056 Max.
F	1/32 R.	1/16 R.	3/32 R.	1/8 R.	1/8 R.
D <sub>F</sub>	DC + 5/16"	DC + 1/2"	DC + 3/4"	DC + 1"	DC + 1"
W <sub>B</sub>	.093 ± .003	.125 ± .003	.187 ± .003	.250 ± .003	.250 ± .004
H <sub>B</sub>	.094 ± .004	.135 ± .004	.200 ± .005	.270 ± .006	.270 ± .008

#### NOTES:

1. Height tolerances is ±.015"
2. This "V" rib is for diaphragm processing only and it may not appear on all diaphragms. It is not functional and need not be completely filled. Rib is normally on rubber side of diaphragm.
3. Two "V" ribs may be used on beads that are .25 or larger in width.
4. Number, size, spacing and location of "V" ribs may be modified to suit specific beads, or may be left off altogether.

#### 5. Trim tolerances

##### Hole Diameter OD Trim

Diameter	Tolerances
0-1.00"	±.010"
1.01-3.00"	±.015"
over 3.01"	±.020"

6. Dimensions and tolerances pertain to Bellofram Rolling Diaphragms as manufactured and not to dimensions and tolerances of mating parts.

## CLASS 3C - STANDARD SIZES

Cylinder Bore DC	Piston Diameter DP	Height K	Sidewall Thickness Wsw	Effective Pressure Area Ae (in) <sup>2</sup>	Convolution C	Maximum Half Stroke SA/SB
.37	.25	.12	B	.07	.062	.11
.68	.32	.21	.014	.19	.183*	.17
.91	.72	.15	.015	.52	.095*	.14
1.00	.75	.16	C	.60	.125*	.07
1.12	.93	.15	C	.83	.094	.08
1.37	1.18	.15	C	1.28	.094	.08
1.50	1.31	.15	C	1.55	.094	.08
1.75	1.56	.15	C	2.15	.094	.08
1.18	1.00	.15	.016	.93	.093	.08
2.00	1.81	.15	C	2.85	.094	.08

\* Special Convolution width

Cylinder Bore DC	Piston Diameter DP	Height K	Sidewall Thickness Wsw	Effective Pressure Area Ae (in) <sup>2</sup>	Convolution C	Maximum Half Stroke SA/SB
2.25	2.06	.15	C	3.65	.094	.20
2.37	2.18	.15	C	4.07	.091	.08
2.50	2.31	.15	C	4.54	.095	.08
3.00	2.69	.25	D	6.35	.155	.15
4.25	3.75	.37	F	12.56	.250	.24
6.00	5.50	.37	.035	25.96	.250	.24
6.75	6.25	.38	F	33.18	.250	.26
7.50	7.00	.37	F	41.28	.250	.24
8.00	7.50	.37	.035	47.17	.250	.24

Side Wall Thickness

B = approx. .015

C = approx. .017

F = approx. .035

## CLASS 1A DIAPHRAGMS

### DESCRIPTION

The Class 1A Bellofram Rolling Diaphragm includes "O"-Ring type bead around the entire circumference of its mounting edge. It is designed for installations requiring minimum outside flange diameter.

This construction eliminates the need for wide flanges, and in some cases, also eliminates the need for flange bolts or flange studs. It requires no perforations or bolt holes through the flange of the diaphragm.

As in other top hat diaphragms, the Class 1A diaphragm requires inversion upon installation and a curved lip retainer is suggested to prevent the piston corner radius from returning to its "as-molded" shape.

In some special designs the Class 1A diaphragm can be provided as a pre-convoluted style with a permanently molded convolution. This pre-convoluted design is easier to assemble. However, it does have the small spring gradient and centering effect which is present in other pre-convoluted designs. A flat retainer plate can be used to retain the head portion of pre-convoluted Class 1A diaphragms.

The cross-sectional area of the bead groove and the hardware for retaining the bead should be equal to the cross-sectional area of the Bellofram bead itself. The corners of the groove should be machined square with minimum fillets. These practices are recommended to provide best retention of the bead without over stressing the elastomer and fabric in the bead. If the groove area is too small, it will cause excessive compression on the elastomer and subsequent damage to the rolling diaphragm.

It is recommended that this design be used where differential pressures do not exceed 150 psi.



Diaphragms are shown in the "as molded" configuration. The diaphragm must be inverted prior to installation.

### DIMENSIONS AND TOLERANCES

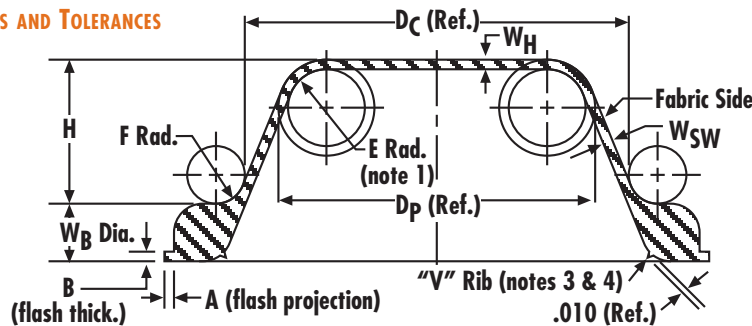

D <sub>C</sub>	1.00 to 2.50	2.51 to 4.00	4.01 to 8.00	8.01 and up
H	As required to yield design stroke (See standard size tables & note #2)			
D <sub>C</sub>	Tolerances on D <sub>C</sub> and D <sub>p</sub> are ± .010" per inch of diameter but the tolerance will be no less than ±.010" or greater than ±.060"			
D <sub>p</sub>				
W <sub>H</sub>	.020 ± .005	.030 ± .005	.035 ± .005	.045 ± .007
W <sub>SW</sub>	.017 ± .003 (Code "C")	.024 ± .004 (Code "D")	.035 ± .005 (Code "F")	.045 ± .007 (Code "H")
A	.025 Max.	.035 Max.	.040 Max.	.056 Max.
B	.025 Max.	.035 Max.	.040 Max.	.056 Max.
E	1/16 R.	3/32 R.	1/8 R.	1/8 R.
F	1/32 R.	3/64 R.	1/16 R.	1/16 R.
W <sub>B</sub> Dia.	.121 ± .005	.151 ± .005	.242 ± .010	.242 ± .010

#### NOTES:

1. This radius is not the piston radius since the head corner will be inverted at assembly
2. Height should not exceed the bore (D<sub>C</sub>). Tolerance on height to be no less than ±.015" per inch of height.
3. This "V" rib is for diaphragm processing only. It may not appear on all diaphragms. It is not functional and need not be completely filled. Rib is normally on rubber side of diaphragm.
4. Number, size, spacing and location of "V" ribs may be modified to suit specific beads, or may be left off altogether.

#### 5. Trim tolerances

Hole Diameter OD Trim	Tolerances
Diameter	
0-1.00"	±.010"
1.01-3.00"	±.015"
over 3.01"	±.020"

6. Dimensions and tolerances pertain to Bellofram Rolling Diaphragms as manufactured and not to dimensions and tolerances of mating parts.

### CLASS 1A - STANDARD SIZES

Cylinder Bore DC	Piston Diameter DP	Height H	Sidewall Thickness Wsw	Effective Pressure Area Ae (in) <sup>2</sup>	Convolution C	Maximum Half Stroke Sa/Sb
1.00	.81	.62	C	.64	.094	.24
1.68	1.50	.75	C	1.99	.093	.38
1.75	1.53	.44	.017	2.11	.110*	.01
2.00	1.81	1.03	C	2.85	.094	.53
3.51	3.05	3.51	.025	8.44	.230*	2.87

\* Special Convolution width

Cylinder Bore DC	Piston Diameter DP	Height H	Sidewall Thickness Wsw	Effective Pressure Area Ae (in) <sup>2</sup>	Convolution C	Maximum Half Stroke Sa/Sb
3.75	3.43	2.25	D	10.14	.156	1.69
4.50	4.00	5.25	.034	14.18	.250	4.22
5.25	4.75	3.18	.034	19.63	.250	2.34
5.50	5.00	5.50	F	21.64	.250	4.47
6.25	5.75	5.25	F	28.27	.250	4.22

#### Side Wall Thickness

C = approx. .017  
 D = approx. .024  
 F = approx. .035

**CLASS 1B DIAPHRAGMS**

**DESCRIPTION**

The Class 1B design utilizes a rectangular shape bead around the entire circumference of its mounting edge allowing the flange bead to be clamped inside the cylinder bore. This design offers a minimum outside housing diameter which is slightly larger than the diaphragm cylinder bore.

In some cases, this design eliminates the need for flange bolts or flange studs. It requires no bolt holes or perforations through the flange of the diaphragm.

Inversion of the piston corner radius is required to form the convolution. In order to retain the piston corner radius and prevent it from returning to its "as molded" shape, a curved lip retainer is recommended.

Because the Class 1B design provides for clamping the flange bead inside of the cylinder bore, the stroke capability is normally limited to the half-stroke in the  $S_p$  direction only.

The cross-sectional area of the groove for retaining the bead should be equal to the cross-sectional area of the Bellofram bead itself. The corners of the groove should be machined square with minimum fillets. These practices are recommended to provide best retention of the bead. Elastomers are not compressible, and if the groove area is too small, it will definitely damage the rolling diaphragm.

It is recommended this design be used where differential pressures do not exceed 150 psi.

**DIMENSIONS AND TOLERANCES**

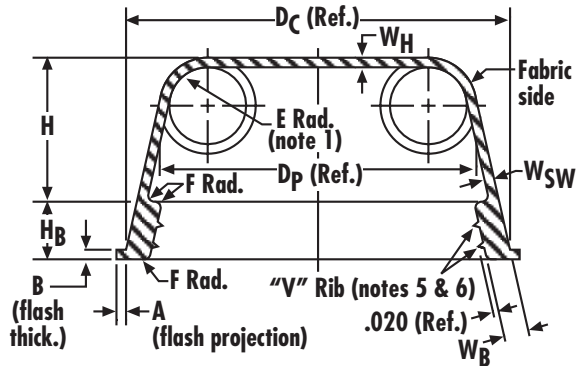

Diaphragms are shown in the "as molded" configuration. The diaphragm must be inverted prior to installation.



D <sub>C</sub>	1.00 to 2.50	2.51 to 4.00	4.01 to 8.00	8.01 and up
H	As required to yield design stroke ( See standard size tables & note #2)			
D <sub>C</sub>	Tolerances on D <sub>C</sub> and D <sub>p</sub> are ± .010" per inch of diameter but the tolerance will be no less than ± .010" or greater than ±.060"			
D <sub>p</sub>	Tolerances on D <sub>C</sub> and D <sub>p</sub> are ± .010" per inch of diameter but the tolerance will be no less than ± .010" or greater than ±.060"			
W <sub>H</sub>	.020 ± .005	.030 ± .005	.035 ± .005	.045 ± .007
W <sub>SW</sub>	.017 ± .003 (Code "C")	.024 ± .004 (Code "D")	.035 ± .005 (Code "F")	.045 ± .007 (Code "H")
A	.025 Max	.035 Max.	.040 Max.	.056 Max.
B	.025 Max.	.035 Max.	.040 Max.	.056 Max.
E	1/16 R.	3/32 R.	1/8 R.	1/8 R.
F	1/32 R.	3/64 R.	1/16 R.	1/16 R.
W <sub>B</sub>	.080 ± .003	.100 ± .003 See note #3	.120 ± .003 See note #3	.160 ± .003 See note #3
H <sub>B</sub>	.150 ± .005	.200 ± .005	.260 ± .005	.300 ± .005

**NOTES:**

1. This radius is not the piston radius since the head corner will be inverted at assembly
2. Height should not exceed the bore (D<sub>C</sub>). Tolerance on height to be no less than ±.015" per inch of height.
3. This tolerance does not include sidewall variation
4. Trim tolerances  
Hole Diameter OD Trim  
Diameter Tolerances  
0-1.00" ±.010"  
1.01-3.00" ±.015"  
over 3.01" ±.020"
5. This "V" rib is for diaphragm processing only. It may not appear on all diaphragms. It is not functional and need not be completely filled. Rib is normally on rubber side of diaphragm.
6. Number, size, spacing and location of "V" ribs may be modified to suit specific beads, or may be left off altogether.
7. Dimensions and tolerances pertain to Bellofram Rolling Diaphragms as manufactured and not to dimensions and tolerances of mating parts.

**CLASS 1B - STANDARD SIZES**

Cylinder Bore DC	Piston Diameter DP	Height H	Sidewall Thickness Wsw	Effective Pressure Area Ae (in) <sup>2</sup>	Convolution C	Maximum Half Stroke Sa/Sb
3.00	2.68	1.19	D	6.35	.156	.63
3.06	2.57	3.32	.035	6.22	.245*	2.34
3.62	3.12	3.31	.035	8.94	.250*	2.33
3.62	3.12	3.87	.035	8.94	.250*	2.89
4.15	3.65	1.95	.035	11.94	.250	.95
4.15	3.65	3.19	.035	11.94	.250	2.19

\* Special Convolution width

Cylinder Bore DC	Piston Diameter DP	Height H	Sidewall Thickness Wsw	Effective Pressure Area Ae (in) <sup>2</sup>	Convolution C	Maximum Half Stroke Sa/Sb
4.75	4.25	3.68	.035	15.90	.250	2.55
4.75	4.25	5.21	.035	15.90	.250	4.08
6.50	6.00	4.34	.040	30.67	.250	3.01
6.50	6.00	7.35	.040	30.67	.250	6.02
7.00	6.50	4.81	.040	35.78	.250	3.48
7.00	6.50	7.36	.040	35.78	.250	6.05

Side Wall Thickness  
D = approx. .024  
F = approx. .035

## INVOLUTED DIAPHRAGMS

Involute Diaphragms may be made depending on design parameters.

### DESCRIPTION

The patented\* Bellofram Involute Diaphragm (IVD)<sup>TM</sup> represents a new concept in rolling diaphragm design. Developed initially to satisfy the needs of the automotive industry for low-cost hardware, small package size and lower assembly cost, the design offers significant advantages over convoluted diaphragms in many applications.

Involute diaphragms differ in both configuration and operation from the conventional designs. IVD diaphragm sidewalls drop almost straight down from the small (piston) diameter, then swing out to the flange in a large, sweeping corner radius. This compares with a more pronounced taper and tighter corner radius for standard BRD.

In operation, the characteristic 180° convolution is not present at the top and bottom of the stroke, but appears only during a portion of the piston travel. The total half-stroke length is equal to the full, molded height of the diaphragm.

This design provides substantial benefits, particularly in the economies that result in the design and construction of associated hardware and in assembly costs.

Installation is quick and easy, since there is no need to form the convolution before the IVD diaphragm is installed. Also, the retainer plate can usually be omitted, and it is frequently unnecessary to fasten the diaphragm to the piston face in any way.

### FEATURES AND ADVANTAGES OF THE INVOLUTED DIAPHRAGM

**Rolling Diaphragm Features** – It provides the same features and advantages generally associated with Bellofram Rolling Diaphragms.

**Reduced Hardware Size** – Without a long piston skirt, the entire cylinder assembly can be substantially reduced in overall size and weight.

**Retainer Plate Fastener** – In most applications a retainer plate is not necessary, and it is frequently unnecessary to fasten the diaphragm to the piston in any way.

**Reduced Diaphragm Size** – Because it provides a 1/2 stroke length equal to its full length, the involuted diaphragm can be shorter than conventional diaphragm.

**Easy & Inexpensive to Install** – It is installed without forming the convolution. This saves labor time and reduces special tooling needs.

**Reduced Hardware Costs** – The generally looser tolerances and finish requirements permit the use of relatively inexpensive hardware, such as die castings, stampings and molded plastic parts.

**Minimum Pressure Reversal Problems** – An involuted diaphragm actuator has a “self-clearing” tendency which allows for slight pressure reversals without damaging the diaphragm.

*NOTE: Since IVD does not stay in convolution at SA & SB extremes, volume displacement will vary as applied pressures are adjusted.*

## INVOLUTED DIAPHRAGM FABRIC DATA

The effective pressure area of an IVD is constant as long as the diaphragm is in a full 180° convolution. It will change as the diaphragm rolls out of a 180° convolution at each end of the stroke.

As the IVD rolls out of 180° convolution the working pressure capability decrease.

See Table of Working Pressure (page 23) for pressure rating factors at various positions in the stroke.



Fig. 11: Comparative rolling diaphragm cross-section

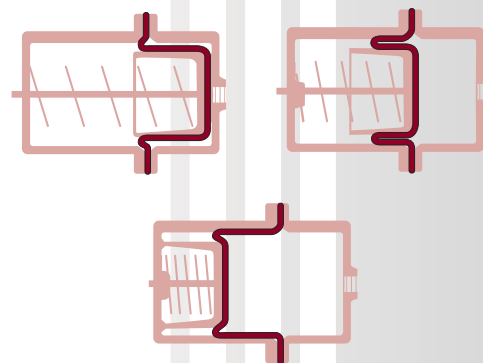

Fig. 12: Standard rolling diaphragm cycle. Convolution is present at all times.

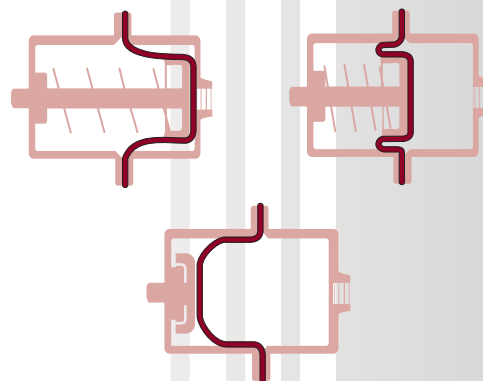

Fig. 13: Involute Diaphragm cycle. Convolution is not required at stroke limits.

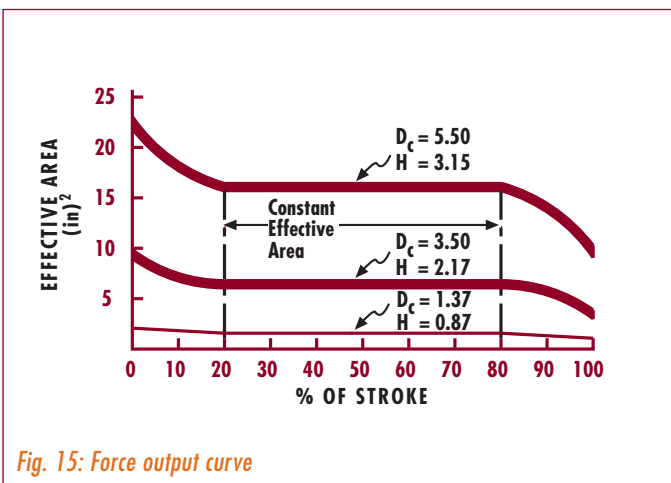

Fig. 15: Force output curve

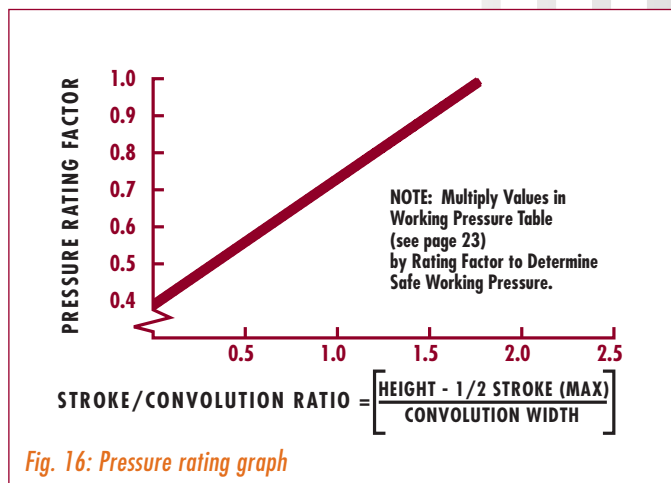

Fig. 16: Pressure rating graph

\* Patent #3,969,991

## ELASTOMER DATA

Diaphragms are available in a broad range of elastomers. Choice of material will depend on the specific environment in which the diaphragm is to operate. The tables below provide the most of the data needed for elastomer selection. In general, however, Bellofram engineers will include a specific elastomer recommendation when they submit a quotation. Temperature Listings are Stationary Temperatures and not Cycle Temperatures.

## DIAPHRAGM ELASTOMER PROPERTIES

CODE	TYPE (1)	COLOR	AIR PERMEABILITY RATING (2)	OPERATING TEMPERATURE LIMITS		PROPERTIES
				°C	°F	
A	SI	RED	180.00	-85 to 260	-121 to 500	General purpose, low temperature
B	SI	RED	170.00	-54 to 315	-65 to 599	General purpose, high temperature
C	SI	TRANSLUCENT	260.00	-51 to 232	-59 to 450	Food grade
F	FSI	RED	50.00	-57 to 232	-70 to 450	General purpose, oil & fuel resistant, temperature extremes
G	FSI	RED	62.00	-60 to 232	-76 to 450	Oil resistant, temperature extremes
J	NBR	BLACK	0.81	-40 to 120	-40 to 248	General purpose, oil resistant, used in stock diaphragms
K	NBR	BLACK	0.46	-40 to 120	-40 to 248	Food grade, taste free, oil resistant
L	NBR	BLACK	1.10	-54 to 120	-65 to 248	Oil and ozone resistant, low temperature
53	NBR	BLACK	0.85	-54 to 120	-65 to 248	Automotive, oil and ozone resistant, low temperature
59	NBR	BLACK	0.28	-35 to 127	-31 to 260	Excellent oil and fuel resistant, high strength
285	HNBR	BLACK	N/A	-40 to 150	-40 to 302	Oil and high temperature resistant
M	CR	BLACK	1.40	-35 to 120	-31 to 248	Weather resistant, fair oil resistance
N	EPDM	BLACK	9.60	-40 to 150	-40 to 302	Steam, ozone, acid and alkali resistant
936	EPDM	BLACK	9.60	-46 to 150	-50 to 302	Food grade, taste free, ozone, acid and alkali resistant
W	ACM	BLACK	1.50	-29 to 177	-20 to 350	Hot oil and ozone resistant
174	ECO	BLACK	0.69	-40 to 150	-40 to 302	Automotive, high temperature
175	CO	BLACK	0.14	-23 to 150	-10 to 302	Oil resistant, extremely low permeability
V	FPM	BLACK	0.32	-17 to 288	1 to 550	Oil, fuel and chemical resistant, high temperature
270449	FPM	BLACK	0.32	-24 to 260	-11 to 500	Oil, fuel and chemical resistance

### NOTES:

- ACM = Polyacrylate  
 ECO = Epichlorohydrin Copolymer  
 CR = Neoprene  
 CO = Epichlorohydrin homopolymer  
 EPDM = Ethylene Propylene  
 FPM = Fluorocarbon  
 HNBR = Hydrogenated Nitrile  
 FSI = Fluorosilicone  
 NBR = Nitrile  
 SI = Silicone

Food Grade versions of listed elastomers generally available

- Permeability ratings are only indicative for the general class of elastomers. The rating X 10-8 indicates the cubic centimeters of air which might be expected to pass through one square centimeter of elastomer, one centimeter thick, in one second, with a pressure differential of 1 atmosphere, at a temperature of 25°C. Permeability is dependent upon type of gas, pressure differential and temperature.



## CHEMICAL RESISTANCE OF DIAPHRAGM ELASTOMERS

Material	General purpose Non-Oil Resistant	General Purpose—Oil Resistant			Specialty Elastomers			
	Ethylene Propylene	Nitrile	Epichlorohydrin	Neoprene	Silicone	Fluoro-Silicone	Fluoro-Elastomer	Fluoro-Elastomer (GFLT)
ASTM Designation	EPDM	NBR	CO	CR	Si	FSi	FPM	FPM
Chemical Group	Ethylene Propylene Diene Monomer	Butadiene Acrylonitrile Copolymer	Epichlorohydrin Polymer and Copolymer	Chloroprene Polymer	Organic Silicone Polymer	Fluorinated Organic and Silicone Polymer	Fluorocarbon Polymer	Fluorocarbon Polymer
Generally Resistant to	Animal and Vegetable Oils, Ozone, Strong and Oxidizing Chemicals	Many Hydrocarbons, Fats, Oils, Greases, Hydraulic Fluids, Chemicals	Similar to Nitrile with Ozone Resistance	Moderate Chemicals and Acids, Ozone, Oils, Fats, Greases, Many Oils and Solvents	Moderate or Oxidizing Chemicals, Ozones, Concentrated Sodium Hydroxide	Moderate or Oxidizing Chemicals, Ozone, Aromatic Chlorinated Solvents, Bases	All Aliphatic, Aromatic and Halogenated Hydrocarbons, Acid, Animal and Vegetable Oils	All Aliphatic, Aromatic and Halogenated Hydrocarbons, Acid, Animal, Vegetable Oils, Fuel Systems (Especially Alcohol Blends)
Generally Attacked by	Mineral Oils and Solvents, Aromatic Hydrocarbons	Ozone, Ketones, Esters, Aldehydes, Chlorinated and Nitro Hydrocarbons	Ketones, Esters, Aldehydes, Chlorinated and Nitro Hydrocarbons	Strong Oxidizing Acids, Esters, Ketones, Chlorinated Aromatic and Nitro Hydrocarbons	Many Solvents, Oils, Concentrated Acid, Dilute Sodium, Hydroxide	Brake Fluids, Hydrazine, Ketones	Ketones, Low Mole Weight Esters, and Nitro-containing Compounds	Ketones, Low Mole Weight Esters, and Nitro-containing Compounds

**FABRIC PERFORMANCE DATA**

The working pressure capability of diaphragms depends on two factors...the strength factor of the fabric reinforcement and the convolution width of the diaphragm. The working pressure is calculated based on the diaphragm being in a full 180° convolution.

Tabulated below are the strength factors for common fabrics used in diaphragms.

Fabric normally used is:			
Code B, for all top hat sizes with:		Code C, for all top hat sizes with:	
$D_C \leq 2\frac{1}{2}"$	(any height)	$D_C > 4"$	(any height)
$2\frac{1}{2}" < D_C \leq 4"$	or $H < D_C / 2$	$2\frac{1}{2}" < D_C \leq 4"$	or $H > D_C / 2$
Code P, for all preconvoluted sizes.			

**FABRIC STRENGTH/USE**

Fabric Code	Type	Strength factor	Duty
A	Polyester	17	General Purpose (Top Hat)
B	Polyester	28	General Purpose (Top Hat)
C	Polyester	47	Heavy Duty (Top Hat)
P	Polyester	32	General Purpose ("C" Style)
V	Nomex	23	High Temperature
L	Polyester	44	Heavy Duty (Top Hat)
W	Polyester Knit	1.8	Light Duty
259	Nomex Knit	1.8	Light Duty, High Temperature

NOTES:

1. Strength factor equals 50% of average tensile strength in lbs/in
2. Strength factor divided by convolution widths equals working pressure in psi

**WORKING PRESSURE**

Fabric Code	Convolution Widths (in.)						
	1/16	3/32	1/8	5/32	3/16	7/32	1/4
A	280	181	136	122	90	78	68
B	459	308	258	185	154	132	116
C	769	515	388	310	258	221	194
V	383	257	193	155	128	110	96
L	728	489	367	294	244	210	184

NOTES:

1. Working pressure values are based on diaphragm being full 180° convolution  
See Figure 16 for pressure rating factors for involuted diaphragms
2. Theoretical burst equals 4 times working pressure

**DEGRADATION FACTORS AT ELEVATED TEMPERATURES**

All materials are subject to heat degradation. This includes both the elastomer and fabric on the diaphragm. The heat degradation of these materials is dependent on temperature, time and environment.

Tensile tested at room temperature after exposure to elevated temperature.

Material at Temperature		1 hr.	10 hrs.	100 hrs.	1,000 hrs.	3,000 hrs.
Nylon	120°C (248°F)	1.00	1.00	.69	.33	
	150°C (302°F)	.91	.60	.38	.00	
Polyester	120°C (248°F)	1.00	1.00	1.00	.93	
	150°C (302°F)	1.00	.92	.77	.65	
Nomex	150°C (302°F)	1.00	1.00	1.00	1.00	1.00
	177°C (351°F)	1.00	1.00	1.00	1.00	.95
	260°C (500°F)	1.00	1.00	1.00	.65	.30

Tensile tested at elevated temperature.

	23°C (73°F)	38°C (100°F)	93°C (200°F)	150°C (302°F)	204°C (400°F)	260°C (500°F)	315°C (600°F)	370°C (700°F)
Nylon	1.00	.93	.75	.61				
Polyester	1.00	.97	.83	.67	.51			
Nomex	1.00	.97	.96	.78	.66	.50	.33	



## HARDWARE DESIGN

### GENERAL

The Bellofram Rolling Diaphragm rolls back and forth from the piston to the cylinder wall. This unique seal employs very simple hardware design that is easy to develop and economical to fabricate.

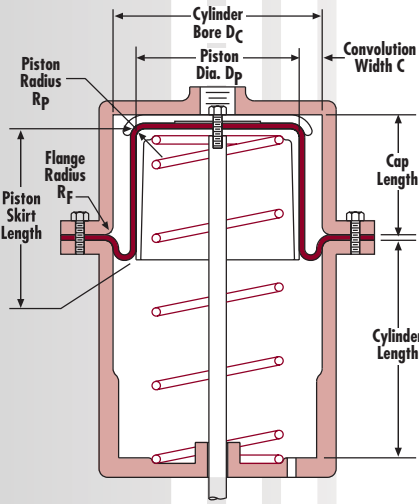

Fig. 17: Hardware Dimensions

Cylinder Bore $D_C$	Convolution Width $C$	Piston Skirt Length	Cap* Length	$R_p$	** $R_f$
0.37 - 0.99	.0625	$\frac{H + S_A}{2}$	Stroke in $S_A$ Direction	.0312	.0312
1.00 - 2.50	.0937	$\frac{H + S_A}{2}$	Stroke in $S_A$ Direction	.0625	.0625
2.51 - 4.00	.1562	$\frac{H + S_A}{2}$	Stroke in $S_A$ Direction	.0937	.0937
4.01 - 8.00	.250	$\frac{H + S_A}{2}$	Stroke in $S_A$ Direction	.125	.125

NOTES:

\*Plus diaphragm head & retainer thickness

\*\*On hardware

### HARDWARE FINISH

One advantage of utilizing Bellofram Rolling Diaphragms is that hardware smoothness is not critical and, therefore, there is no need for expensive, finely machined surfaces. A surface finish of 63 microinches is sufficient for most applications. (For high cycle applications see page 30.)

### CURVED LIP RETAINER PLATES

The head corners of some classes of diaphragms require inversion during assembly to form the convolution. Therefore, it is quite possible, in some installations and under certain operating conditions, that the diaphragm will try to re-invert to its original "as-molded" position, thus causing sidewall "scrubbing". This condition is illustrated in Fig. 18. To eliminate this effect, curved lip retainer plates are recommended to hold the inverted head corner of the **BRD** in intimate contact with the piston head corner. The use of retainer plate in the original piston assembly is highly recommended, since it greatly reduces the possibility of incorrect reassembly of the rolling diaphragm. A recommended curved lip retainer plate design is described below.

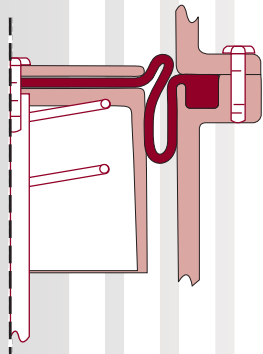

Fig. 18: Diaphragm inversion resulting from lack of curved retainer plate.

Cylinder Bore $D_C$	A	B	C	D	E	F	G. Rad
0.37 - 0.99	$D_p + 2W_{SW}$	Not required	.015	1/16	1/8	Not required	.025
1.00 - 2.50	$D_p + 2W_{SW}$	.7 $D_p$	.025	3/32	3/16	.010	.030
2.51 - 4.00	$D_p + 2W_{SW}$	.7 $D_p$	.030	7/64	7/32	.015	.040
4.01 - 8.00	$D_p + 2W_{SW}$	.7 $D_p$	.030	1/8	1/4	.015	.060

NOTES:

$D_p$  = piston skirt outside diameter

$W_{SW}$  = Max. sidewall thickness of BRD

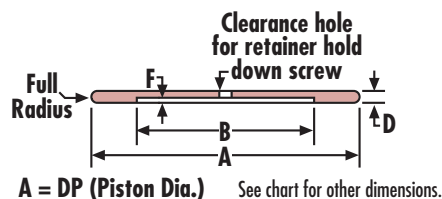

Fig. 19: Flat washer type retainer for Classes 3C and 4C (Pre-convoluted Diaphragms).

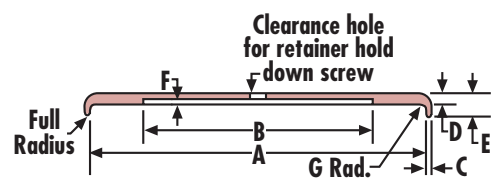

Fig. 20: Curved lip retainer for Classes 3, 4, 1A and 1B ("Top-Hat" Diaphragms).



**HARDWARE DESIGN – CLASS 4 & 4C DIAPHRAGMS**

**DIAPHRAGM FLANGE RETENTION METHODS**

**Crimp Ring (fig. 21)** – This type of flange retention employs a separate metal crimp ring which is assembled to the actuator with properly designed crimp tools and lends itself to low cost, high volume manufacturing. Crimp rings are made of thin ductile material so that the forces required to form the lip will not result in overstressing the diaphragm flange.

**Swaged Lip (fig. 22)** – This is similar to the crimp ring except that the retaining lip is an integral part of either the bonnet or cylinder. Again the crimp lip should be thin and ductile for proper flange assembly and retention. The swaged lip provides a minimum outside diameter for a flat flange, yet lends itself to low cost, high volume production.

**Bolted Flange (fig. 23)** – The most common method of flange retention is the bolted flange design. The perforations should be at least 15% larger than the ID of the flange bolts or studs. A sufficient number of bolts or studs should be used to eliminate any serious distortion or bowing of the flange between the bolts. This provides a pressure-tight seal that prevents flange pull-out of the diaphragm from between the bolts.

**HARDWARE DESIGN - CLASS 3 & 3C**

The dimensions listed below result in a more consistent clamping pressure on the diaphragm bead. The configuration and dimensions of the diaphragm bead and the hardware bead groove provide a convenient means of positioning the diaphragm in the hardware. The bead groove width has been increased, to provide room for the diaphragm bead to deform under compression.

These figures represent a nominal bead compression of 12% (8–18% depending on tolerances), consistent with similar configurations of static "O" ring applications. These relationships may also be applied to non-standard "D" beads.

Cylinder Bore DC (Ref.) Diameter	Bead Groove Width $W_{BG} \pm .003$	Bead Groove Height $H_{BG} \pm .002$	Flange & Piston Corner Radii $R_L$ & $R_p$	Flange Lip Width $W_L \pm .003$	Flange Lip Clearance $C_L \pm .003$
.37 - .99	.109	.082	1/32	.062	.021
1.00 - 2.50	.141	.118	1/16	.125	.021
2.51 - 4.00	.219	.178	3/32	.187	.031
4.01 - 8.00	.281	.238	1/8	.250	.036
8.01 - up	.281	.238	1/8	.250	.048

**NOTE:**  
The above dimensions will provide adequate sealing and retention for practically all applications. Some unusual or special cases may require minor modification

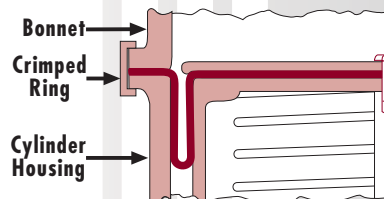

Fig. 21: Crimp-Ring Design

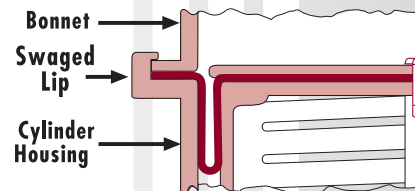

Fig. 22: Swaged Lip

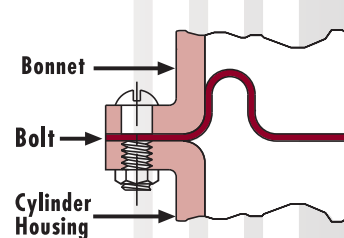

Fig. 23: Bolted Flange

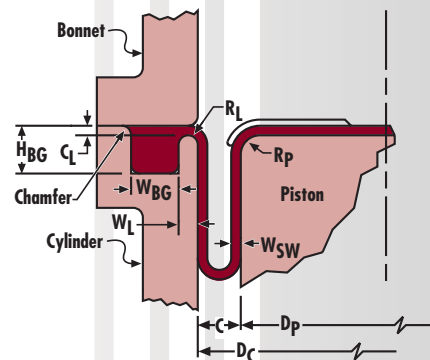
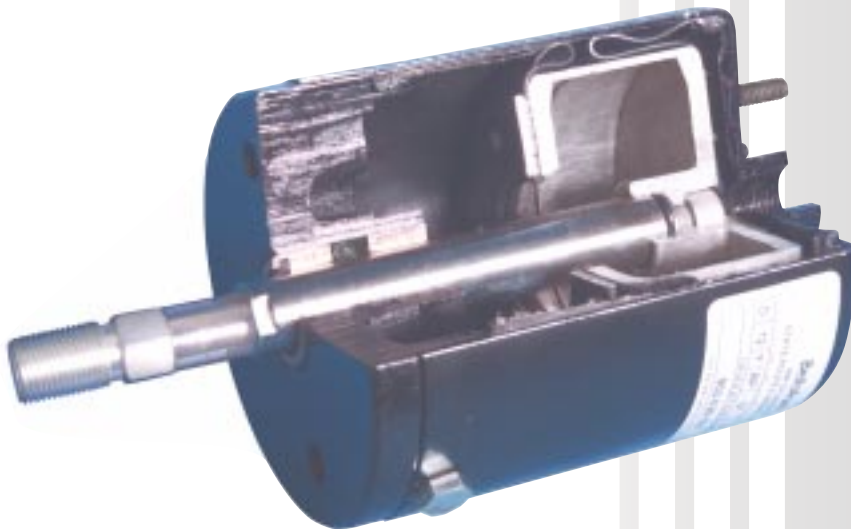

Fig. 24: Classes 3 and 3C Hardware Dimensions



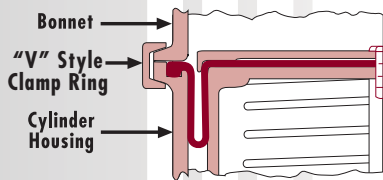

Fig. 25: Ring Clamp

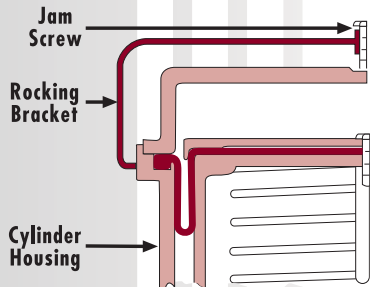

Fig. 26: Pivot Rocking Bracket

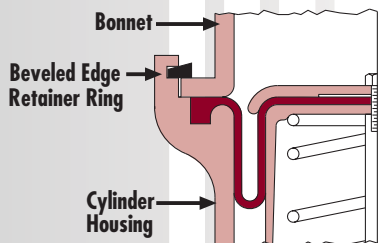

Fig. 27: Beveled Edge Retainer Plate

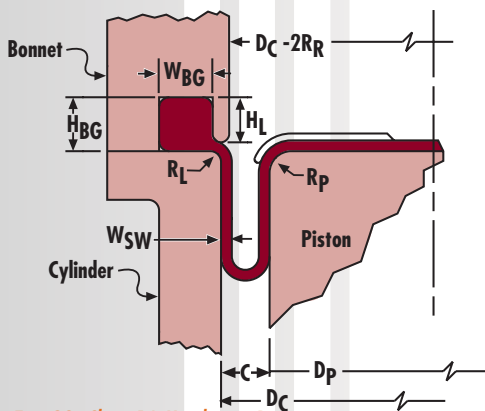

Fig. 28: Class 1A Hardware Dimensions

### DIAPHRAGM FLANGE RETENTION METHODS

**Ring Clamp (fig. 25)** – In order to provide for fast disassembly, a “V” style clamp ring is frequently used. This type of ring can be opened quickly for disassembly by removing one toggle clamp lever. The retainer plate is provided with a “keyhole slot” and the retaining screw is provided with two wings which bear against the top surface of the retainer plate. This retainer plate is quickly removed by turning it 90° at which point the wings and the bolt drop into the keyhole slots. In general, this design is for low pressures.

**Pivoted Rocking Bracket (fig. 26)** – This is another low cost design which also has the advantage of quick assembly and disassembly. A pivoted rocking bracket is attached to the housing flange. The central jam screw holds the bonnet firmly against the mating flange area. The unit can be disassembled quickly by loosening the screw and pivoting the bracket to release the bonnet assembly and BRD. In general, this design is also limited to low pressure.

**Beveled Edge Retainer Plate (fig. 27)** – By the use of a beveled edge retainer ring, flange bolts can be eliminated. A groove is provided in the extension of the cylinder housing flange and during assembly the beveled edge ring is snapped into the groove which, in turn, loads the bonnet assembly onto the mating bead. Generally, the clamping forces produced by a design of this type are fairly low, and therefore, these applications should be restricted for use with low pressure.

### HARDWARE DESIGN (fig. 28) - CLASS 1A

The Class 1A bead is placed into a closely machined bead groove. It seals by axially compressing the bead into a bead groove of lesser height (usually about 12% compression) with allowance in the bead groove width for radial displacement.

Cylinder Bore Diameter $D_C$ (Ref.)	Bead Groove Width $W_{BG} \pm .002$	Bead Groove Height $H_{BG} \pm .002$	Flange & Piston Corner Radii $R_L$ & $R_p$	Lip Radius $R_R \pm .005$	Lip Height $H_L \pm .005$
1.00 - 2.50	.125	.096	1/16	.025	.100
2.51 - 4.00	.156	.122	3/32	.032	.130
4.01 - 8.00	.250	.196	1/8	.045	.204
8.01 - up	.250	.196	1/8	.045	.190

**NOTES:**

The above dimensions will provide adequate sealing and retention for practically all applications. Some unusual cases may require minor modification.

### DIAPHRAGM BEAD RETENTION METHODS

**Crimped Ring (fig. 29)** – The use of a crimped ring to retain the diaphragm, coupled with die cast bonnet and cylinder lends itself to low cost hardware design and high volume production. This unique design eliminates conventional flange construction as well as the need for bolted type construction.

**Grooved Bonnet (fig. 30)** – In some installations it is desirable to use a drawn metal cylinder housing with a molded or die cast bonnet. In installations of this nature it is recommended to make a provision for the bead groove in this molded or cast bonnet. The housing should be retained by a sufficient number of circumferential clamp bolts to prevent distortion between flange bolts.

**Bezel Ring or Grooved Bonnet (fig. 31)** – Many applications require absolute minimum outside diameter of the housing in the plane of the bead retention. A fairly common method of fastening the bonnet to the cylinder housing, and at the same time providing adequate retention, is by using a threaded bezel ring as shown.

The male threads are machined on the cast bonnet in order to make use of low cost drawn sheet metal cylinder housings.

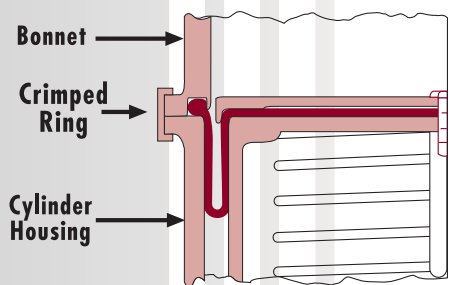

Fig. 29: Crimped Ring

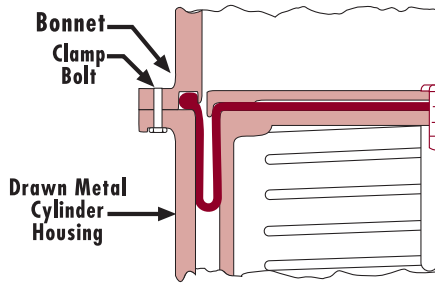

Fig. 30: Grooved Bonnet

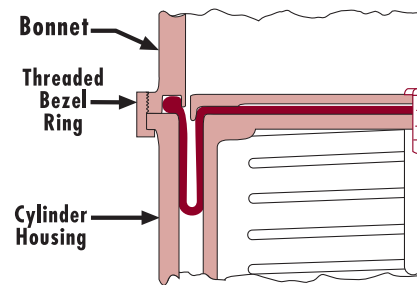

Fig. 31: Bezel Ring or Grooved Bonnet

**HARDWARE DESIGN - CLASS 1B**

The Class 1B relies on a complete volumetric fill of the retaining hardware. In order to provide proper sealing, radial compression of the bead is not essential. Under a differential pressure the bead pulls down and tightly seals against the retainer.

Cylinder Bore Diameter $D_C$ (Ref.)	Bead Groove Width $W_{BG} \pm .002$	Bead Groove Height $H_{BG} \pm .002$	Lip Radii $R_R \pm .005$	Piston Corner Radius $R_p$	Lip Clearance $C_L \pm .003$
1.00 - 2.50	.080	.150	.030	1/16	.023
2.51 - 4.00	.100	.200	.040	3/32	.032
4.01 - 8.00	.120	.260	.050	1/8	.043
8.01 - up	.160	.300	.060	3/16	.059

- NOTES:
1. Alternate construction use where adequate clearance is available, or where reduced half-stroke is usable. (see Fig. 33)
  2. Reduce hardware by .005 for radial compression configuration.
  3. The above dimensions will provide adequate sealing and retention for practically all applications. Some unusual cases may require minor modification.

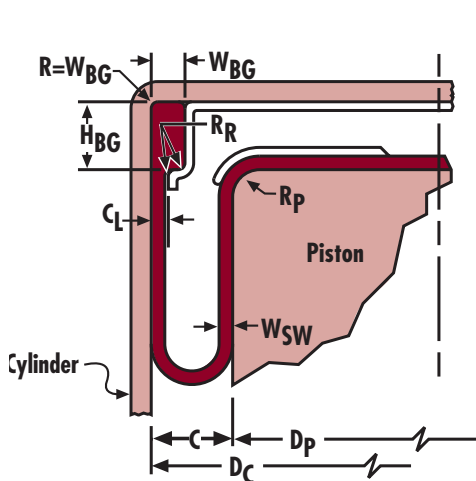

Fig. 32: Axial Compression with Stamped Retainer Plate

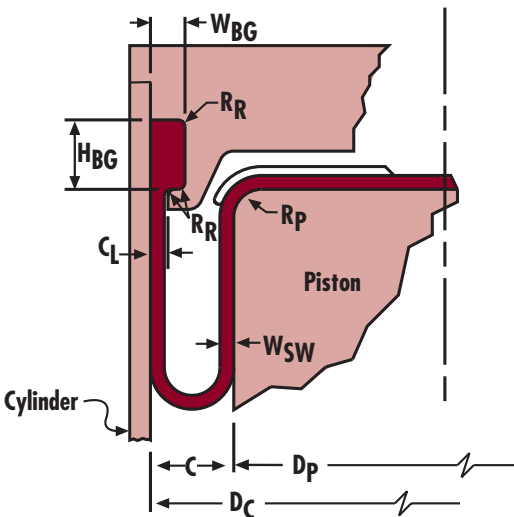

Fig. 33: Radial Compression (note 1) with Cast Machined Retainer Plate

**DIAPHRAGM FLANGE RETENTION METHODS**

**Stamped Retainer Plate (fig. 32)** – A stamped retainer plate can be utilized, as is shown, which pulls up on the bead and seals against the cylinder bore. This is a very economical design which utilizes low cost hardware and ease of assembly. The piston diaphragm retainer assembly slides up inside the cylinder shell and the retainer is fastened to the top of the shell with seal nuts.

**Cast or Machined Retainer Plate (fig. 33)** – An alternate design shown is a machined, cast, or tip retainer which allows for retention of the bead at the open end of the cylinder shell. The diaphragm bead and retainer bead groove are dimensionally the same as the previous method discussed.

Both of these methods of Class 1B bead retention are employed in the variety of single and double acting diaphragm air cylinders manufactured by Bellofram.



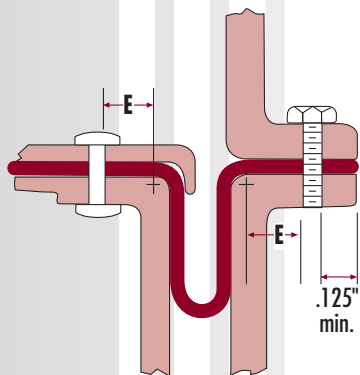

Max. Working Pressure (PSI)	0-50	51-150	151-300	301-500
"E" Minimum (in.)	.100	.150	.200	.250

Fig. 36: Hole Spacing Dimensions

## APPLICATION DATA

### DESIGNING FOR DIAPHRAGM TRIM & PERFORATION

Some **BRD** require perforations through the flange or head to accommodate a fastening means either to the flange or head. This necessitates a punching operation for head holes, flange holes, or trimming the outside flange periphery, so that the rolling diaphragm will mate with the configuration of the piston, bonnet or cylinder housing.

We recommend that all perforations or flange trim be performed by us prior to shipment. Please submit sketches of required perforations or trim with quotation request, or with your order. Good design procedures for trim and perforation are as follows:

**Relationship of Hole Pattern** – Whenever there are holes in the head and flange, always indicate whether the hole pattern in the head and the hole pattern in the flange must be trimmed with a definite angular relationship. The manufacture of trim tools which will maintain this fixed angular orientation involves additional expense.

**Hole Spacing** – Perforations through the head or the flange should be located so that there is at least .100 inches minimum between the edges of holes. Also, holes must be located so that there is at least .125 inches between the edge of a hole and the trim periphery. If the bolt holes are less than this distance, the holes should be "notched" similar to shown in photo. It is also important to arrange the hole pattern so that the radial distance from the edge of the hole is at least "E" inches from the start of the blend radius at either the piston head or cylinder clamp flange. This condition is illustrated (in Fig. 36) and the "E" dimension is given for various working pressures.

**Hole Diameters** – Perforations should generally be designed to have a diameter of .093 inches or greater, in increments of .015 inch. The diameter of all perforations should provide a radial clearance between the maximum diameter of bolts and the perforated hole of at least 15% of the bolt diameter. This design practice is most important in order to eliminate the possibility of fraying the edge of the perforations during assembly by insertion of screws, etc.

**Head Perforations** – The size and number of perforations in the head should be kept to an absolute minimum since the load bearing threads supporting the side wall and convolution pressure loads are actually severed by these perforations. Whenever bolt holes in the head are required, they should be placed as close to the center of the head as possible, and the hole diameters should be kept to a minimum.

**Drawings Specifying Trim and Perforations** – It is requested that a sketch or drawing be submitted indicating required perforations and trim. Make sure sketches are in accordance with these recommendations. Hole punching, perforations, and flange trimming are provided at no extra cost by the Bellofram Corp. There is, however, a fee for the design and manufacture of special trim and perforation tools.



Fig. 37: Notched Diaphragm

### FORMING THE CONVOLUTION DURING ASSEMBLY

To form the diaphragm convolution during assembly operations. Classes 4, 3, 1A & 1B ("Top-Hat") designs require that the head corner of the **BRD** be inverted from the "as-molded" configuration to the "as-installed" configuration. The pre-convoluted designs, Classes 3C and 4C, do not require any inversion since they are molded in a convoluted configuration.

### ALTERNATE METHODS OF ATTACHING DIAPHRAGM TO PISTON

Whenever it is undesirable to attach the diaphragm to the piston head by means of rivets, screws, etc., which require a hole through the head of the diaphragm, attachment may be made by either of the following means:

1. Double Sided Pressure Sensitive Tape: Apply to one of the areas to be bonded and then press on the mating surface. Clean all surfaces to be bonded with perchlorethylene and acetone to remove all surface films. It may be necessary to abrade the surfaces prior to cleaning to obtain improved bonds.

The tape should be die cut in the shape of a disc with the diameter equal to the piston head diameter allowing sufficient margin for the disc to form down over the head corner radius. To prevent pleating in the area of the head corner radius, the head disc should be die cut with frequent notches.

The above procedure works well with most elastomers, however, for bonding silicone to metal piston heads, see below.

2. Liquid Cements: in using liquid cements or semi-liquid cements for bonding a diaphragm to a piston head, the cement must be restricted to the area to be bonded. The adhesive should be applied to the entire top surface of the piston including the head corner and to the mating "Fabric side" of the diaphragm. Any cement which inadvertently comes in contact with the sidewall area of the piston of the diaphragm (excluding the Head Corner Radius) must be completely removed prior to application, of the diaphragm.

All surfaces must be pre-cleaned as noted previously.

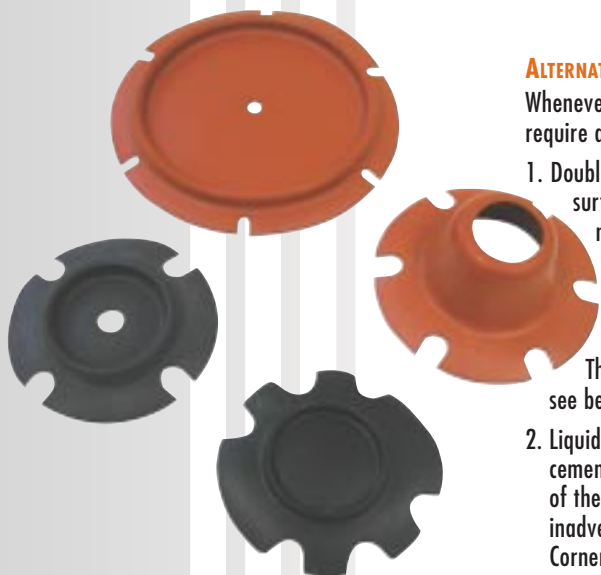

**EFFECTS OF PRESSURE REVERSAL**

Any condition which introduces even a temporary pressure reversal may cause sidewalls distortion, overstressing, and a scuffing action, similar to that indicated in Fig. 38. Generally, any pressure reversal causing multiple pleats will not be corrected by application of pressure on the high pressure side. Operation with pleats will result in early failure of the diaphragm.

**SURFACE COATINGS**

In order to prevent possible adhesion of elastomeric material of a diaphragm to mating material surfaces, especially under heavy clamping loads, a surface release agent should be applied to surfaces in intimate contact with metal surfaces. This release agent is of a particular importance whenever frequent disassembly of the unit is required for inspection purposes. Two of the commonly used release agents are silicone oil, wiped on appropriate BRD surfaces, and Molykote. These release agents should be thoroughly worked into the surface of the fabric side and the elastomer side prior to installation.

**PISTON ECCENTRICITY**

Any piston-cylinder eccentricity experienced during a normal operating stroke should be minimized in order to provide a uniform convolution width around the entire periphery. In general, the eccentricity should not exceed 10% of the working convolution width. If piston shaft bearings are provided, the bearing installation should be designed so that the overall eccentricity of the piston with respect to the cylinder is within these limits over the entire operating stroke of the mechanism.

In many applications, shaft bearings are not required since the shaft itself is guided by some other related mechanism. Whenever the applied thrust is not parallel to the piston shaft axis, it is well to provide an alignment bearing. If a spring is employed to return the piston to its top stroke position, some means for insuring concentric motion of the piston during its stroke should be provided. In general, compression springs do not have a motion parallel to the spring axis, thus introducing a bending moment at the head of the piston.

**SHAFT TORQUE**

If there is a possibility that the piston shaft may be subjected to wrenching or other torques during assembly or operation, a rotating slip joint is recommended in order to prevent the torque from being transmitted to the BRD. A typical shaft assembly having a slip joint to prevent this transmission of torque is shown in Fig. 39. Torque may also be applied to the piston in certain designs using compression springs, when compressed, will twist through an angular displacement. If this twisting effect is more than one half degree, one end of the spring should be supported on a ball bearing thrust plate.

**UP-STOPS AND DOWN-STOPS**

In order to prevent over-stroking, a positive up-stop and down-stop should be provided in every mechanism. These stops, or buffers, prevent the BRD from being damaged by excess travel beyond values.

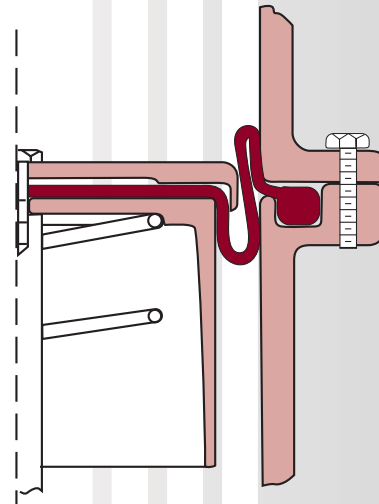

Fig. 38: Pressure Reversal of Diaphragm

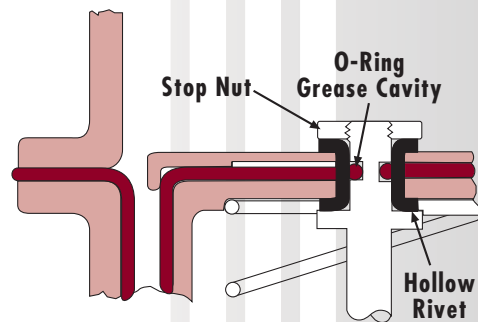

Fig. 39: Slip Joint Shaft Assembly



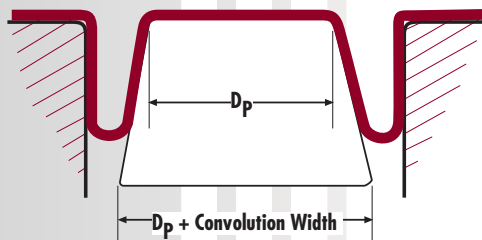

Fig. 40: Tapering the Piston

### DESIGNING FOR INCREASED DIAPHRAGM LIFE

There are many factors which contribute to the durability of Bellofram Rolling diaphragms. Under normal operating conditions the diaphragm will last millions of cycles, but in special situations additional considerations are employed.

**Piston Configuration** – The Rolling Diaphragm must elongate and compress circumferentially as it rolls back and forth from piston to cylinder wall. Tapering the piston (Fig. 40) will contribute to improved cycle life by reducing the amount of circumferential change required of the diaphragm as it rolls back and forth. This tapered configuration relieves the condition which can cause axial wrinkling of the diaphragm. This taper of the bottom of the piston skirt should be such that the convolution at the bottom of the skirt is half the standard width (diameter at bottom of piston skirt is  $D_p$  plus one convolution width). It is important that the piston skirt length be to specification.

This modification is not recommended where cylinder bores are less than 1.00 in. diameter.

**Reduce Stroke** – Reducing the stroke minimizes the amount of diaphragm stretch and circumferential reduction required for the diaphragm.

**Cycle Down ( $S_B$ ) Only** – When the diaphragm moves in the  $S_A$  direction it must compress circumferentially to conform to the piston. These circumferential compressive stresses are the principal cause of axial wrinkling in long stroke diaphragms.

By cycling in the  $S_B$  direction the diaphragm elongates circumferentially avoiding the compressive stresses.

**Pressure Control** – Pressure should be maintained at all times when the diaphragm is moving. In order to minimize fabric stresses, recommended operating pressures should not be exceeded.

Of equal importance there should be sufficient differential pressure maintained to insure that the diaphragm conforms to the hardware. This will preclude any interference and side wall scuffing.

**Decrease Cycle Rate** – Rapid cycle rates can cause cavitation or negative pressures that could force the diaphragm into double-convolution. Double-convolution will cause early diaphragm failure.

As a general rule a maximum cycle rate of one cycle per second is recommended.

**Increase Hardware Smoothness** – In high cycle applications there is some relative movement between the diaphragm sidewall and the mating hardware surfaces. Abrasion results over a prolonged period of operation. Smoothing the hardware surfaces to 32 micro inches will help improve this condition.

In cases of spot failures, check for burns as well as piston/cylinder eccentricities. Wherever possible, Teflon coating the hardware or use of molded plastic in the hardware construction can provide smooth surfaces for long life.

**Lubrication** – Periodic lubrication is not required for a rolling diaphragm, as there is no sliding friction. However, a light coating of molybdenum disulfide (Molykote) on the fabric and/or elastomer side of the diaphragm, prior to assembly, and possibly on the mating hardware, will reduce potential for scuffing.

In some sever applications the fabric side of the diaphragm can be coated with an abrasion-resistant urethane spray.

**Fabric Selection** – fabrics should be selected to provide optimum working pressure capabilities. They should be strong enough to meet the pressure requirements and open enough to allow strong fabric/ elastomer impregnation resulting in strong adhesion.

**Double-Tapered Diaphragms** – Tapering the hardware piston, to relieve the effects of circumferential compression, also means that there will be a change in the effective area from one end of the stroke to the other.

An alternate means of relieving circumferential compressive stresses is the double-tapered diaphragm. This diaphragm is used with a straight piston skirt so there is no change in effective area. The sidewall angle is designed to conform closely to the piston diameter reducing the amount it must compress to conform to the piston skirt.



**APPLICATION DATA DESIGN PARAMETER SHEET**

The Bellofram Engineering Department will be pleased to assist you in the appropriate selection and correct application of Bellofram Rolling Diaphragms. To make a satisfactory analysis of your specific application, we need to have answers to the questions listed below. It would also be helpful to receive a sketch or layout showing the proposed installation details.

Name _____	Title _____	Date _____
Company _____	Fax _____	Phone _____
Address _____	E-mail _____	
City _____	State _____	Zip _____

For explanation of the terms below, see Bellofram Design Manual

1. Cylinder bore diameter \_\_\_\_\_  
or effective pressure area \_\_\_\_\_
2. Piston diameter \_\_\_\_\_
3. Height \_\_\_\_\_
4. Up-Stroke \_\_\_\_\_  
Down-Stroke \_\_\_\_\_
5. Pressure:  
Minimum \_\_\_\_\_  
Normal \_\_\_\_\_  
Maximum \_\_\_\_\_  
Reverse \_\_\_\_\_
6. Temperature:  
Minimum \_\_\_\_\_  
Normal \_\_\_\_\_  
Maximum \_\_\_\_\_
7. Time interval at high temperature \_\_\_\_\_
8. Media in contact with  on:  
Low Pressure side \_\_\_\_\_  
High Pressure side \_\_\_\_\_
9. Estimated number of Expected Cycles \_\_\_\_\_  
Approximate cycle rate \_\_\_\_\_
10. Prototype (Qty.) \_\_\_\_\_  
Prod'n (Qty.) \_\_\_\_\_
11. Delivery requirements \_\_\_\_\_

**PLEASE SKETCH INSTALLATION LAYOUT**

**FOR SAVINGS IN COST AND DELIVERY TIME**

1. For fastest delivery and lowest cost — consult the Standard Size List under the desired class of diaphragms and select the size marked (X) in the left column. Stock items are Nitrile (Buna-N) elastomer reinforced with polyester fabric.
2. If size desired is unavailable in stock sizes, fill in Design Parameter Sheet and send to Bellofram for quotation on cost and delivery.
3. For minimum set-up costs and efficient production: Choose any class and size for which molds are available on the Standard Size List. This eliminates engineering time, mold production delays and cost.
4. To reduce costs on special seals to fit your needs: If 1 and 2 above do not fit your applications, contact Bellofram Diaphragm Applications Engineering Department.
5. In unusual circumstances where standard sizes cannot be used, the least economical seals in time and engineering are those which are designed without regard to standard configuration.

**DIAPHRAGMS PART NUMBER DESIGNATION**

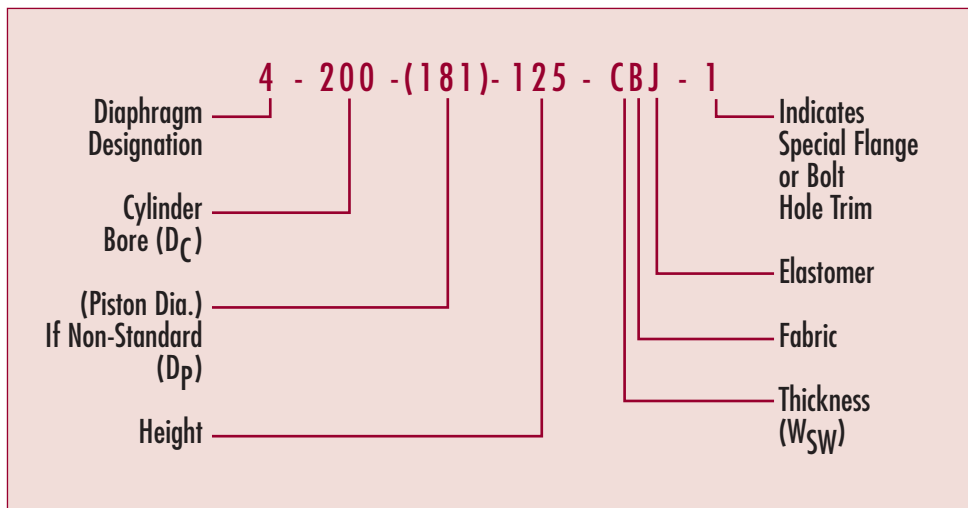

**DIAPHRAGM DESIGN AND APPLICATION ASSISTANCE**

Experienced Bellofram engineers and designers are available to answer questions concerning specific applications and to assist you with design problems, Rolling Diaphragm selection, delivery and price information, etc. If you would like information, just write, call or fax:

Diaphragm Applications Engineering Group  
 State Route 2, Box 305  
 Newell, WV 26050-0607  
 (304) 387-1200  
 800-727-5646  
 FAX: (304) 387-3970

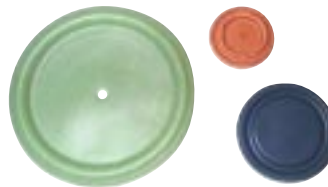

**e-mail: [info@bellofram.com](mailto:info@bellofram.com)**



## SPECIAL PRODUCTS

### DOUBLE COATED DIAPHRAGMS

Bellofram offers double coated technology that uses either coated fabric or Bellofram's flexible lay up process. Our breakthrough in technology frees us from the limited shapes, thickness and materials used in the coated fabric process, enabling us to design double coated diaphragms in a wide variety of materials and configurations — even "top hats." Composites of different elastomers can be used under certain conditions.

### COMPOSITE DIAPHRAGMS

Bellofram composite diaphragms feature a Teflon® coating bonded to the elastomer surface. Composite diaphragms are especially effective in harsh environments. When additional strength is required, they can be reinforced with a fabric.

### HOMOGENEOUS DIAPHRAGMS

Bellofram's homogeneous diaphragms are constructed without reinforcing fabric. They are used in low pressure applications where sensitivity is required.

### PTFE FACED AND INSERTED DIAPHRAGMS

Metal and plastic inserts such as threaded hardware can be bonded into the diaphragm. Our engineering staff can provide you with a wide variety of insert possibilities based on your design requirements.

*Bellofram offers assistance in the design and manufacture of custom diaphragms, and we welcome the opportunity to meet your special requests.*



From concept  
& engineering  
through manufacturing  
processes & packaging  
for shipment,  
Bellofram Diaphragms  
are subject to numerous  
inspections & tests

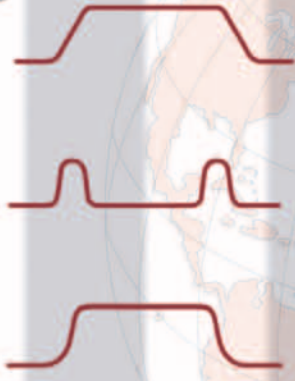

**www.bellofram.com**



USA  
Bellofram Corporation  
State Route 2, Box 305  
Newell, WV 26050-0607  
800-727-5646  
304-387-1200  
FAX: 304-387-3970  
info@bellofram.com



EUROPE  
Marsh Bellofram Europe Ltd.  
Unit 9 Castle Park  
Queens Drive  
Nottingham NG2 1AH  
England  
Tel: 115 993 3300  
FAX: 115 993 3301  
bellofram@aol.com

ISO 9001:2000  
certified

**BRD**

Bellofram Rolling Diaphragm  
DESIGN MANUAL