

# HUMPHREY AIR CYLINDERS

## CONSTRUCTION • Compact • Lightweight • Durable • Economical • Attractive

### SINGLE ACTING AIR CYLINDER

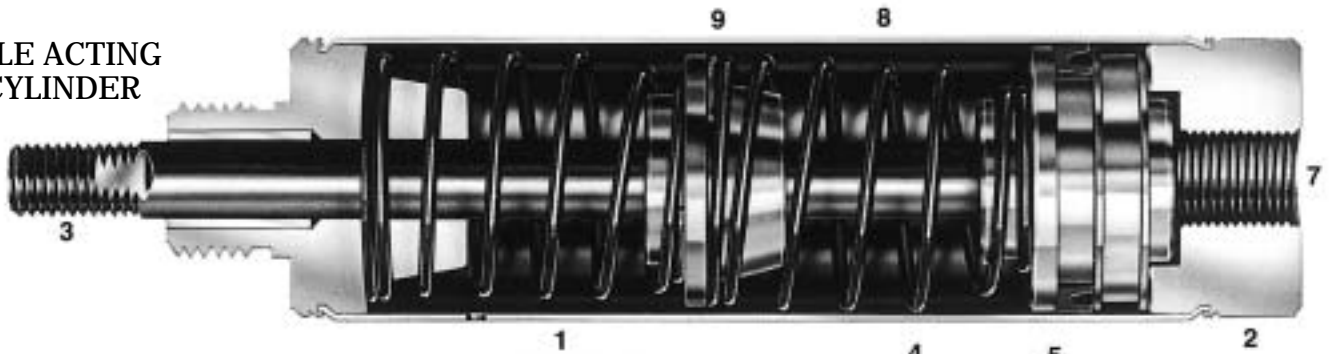

### DOUBLE ACTING AIR CYLINDER

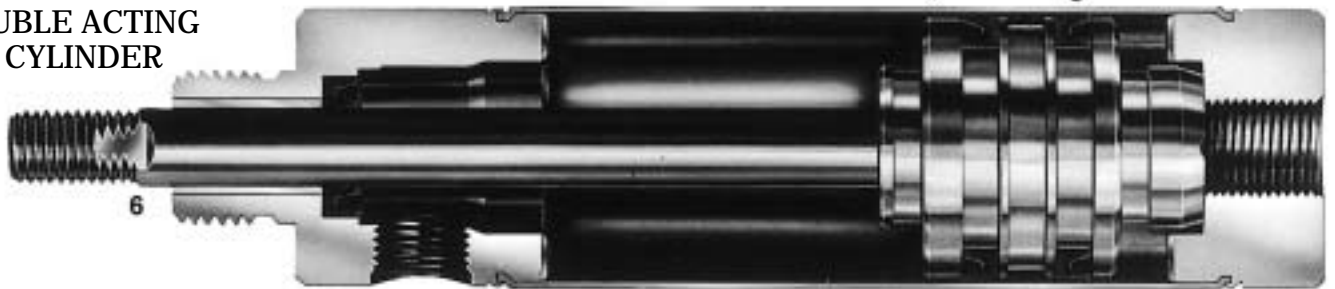

1. **BARREL** Stainless steel (Type 304). Drawn and polished I.D. provides ideal lube-holding, low friction surface. Matte finish on O.D. Barrel attached to heads by Humphrey roll-forming process.
2. **HEADS** Aluminum. Internal face grooved for positive air flow to piston seals.
3. **PISTON ROD** Accuracy stock, centerless ground and polished Type 303 Stainless Steel, standard all models. Wrench Flats, standard most models, chamfered for easy wrench contact without rod damage. Threads are Roll Formed for strength and durability.
4. **PISTON** Unique Humphrey Piston may be factory assembled in two different ways – same overall dimensions with or without Bumpers. Piston threads are Roll Formed for greater strength and durability.
5. **SEALS** Buna N standard on all models. Fluorocarbon (fluoroelastomer...Option F) available for high ambient temperatures; for extremely high cycling conditions with limited lubrication; or mild chemical resistance (air supply contaminants and/or lubricants). Seal design insures constant contact with cylinder barrel...eliminates seal collapse and blow-by.
6. **ROD BUSHING** Oil permeated bronze, ball-sized to close tolerance...provides rod support and smooth, low friction rod movement for longer cylinder life.
7. **PRESSURE PORTS** Full, unrestricted porting for maximum air flow...combines with groove in Heads to provide fast cylinder response and smooth rod movement.
8. **RETURN SPRINGS** High tensile strength music wire. Shotpeened...to relieve stresses for longer life.
9. **SPACERS** Spacers insure a uniform spring rate and prohibit collapse of springs, providing maximum life.

**ACCESSORIES** Steel mounting nuts, mounting brackets, rod clevises, etc., are burnished and bright zinc plated.

### Exclusive Humphrey Reversible Piston

(Patented) shown with Bumpers (Option B) for shock absorption and quiet operation; and Wearstrip (Option N).

Reversible Piston permits addition of Bumpers without changing overall external cylinder dimensions.

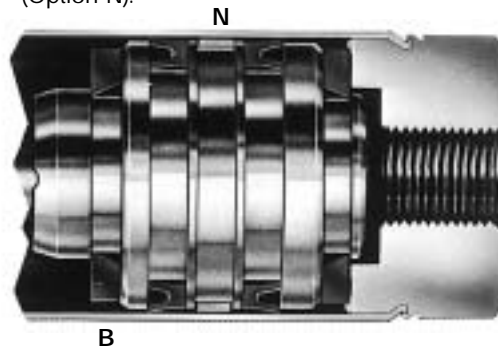

### Humphrey Reversible Piston

Shown with Option M (Internal Magnet) for use with sensors.

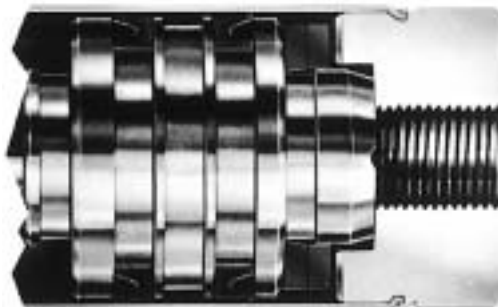

**M** Location of (Internal Magnet)

## SPECIFICATIONS

# HUMPHREY AIR CYLINDERS

- For Compressed Air to 200 PSIG, Hydraulic to 100 PSI (expect rod weep)
- Ambient temperature -40°F to 160°F as standard  
 -20°F to 400°F with Viton seals  
 -10°F to 250°F with ELF seals

**Force (F)** is determined by square inches of piston area (A), and pressure (P) in PSIG,  $F = A \times P$

**Volume (V)** in *cubic inches* is determined by square inches of piston area (A), and length of stroke (L),  $V = A \times L$

**Speed** is affected by many variables (including force to move load, cylinder volume, control valve flow capacity, length of supply lines, etc.)  
 Piston area X inches of stroke - Cubic inches of volume making precise calculations difficult.

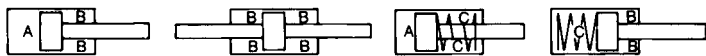

BASIC MODEL NO.	BORE SIZE I.D.	PORT SIZE IN.	ROD DIAMETER OR (HEX)	PISTON AREA SQ. IN. Cylinder Volume CU. IN. per 1 in. of stroke		SPRING FORCE IN POUNDS IF CYL. IS:	
				A	B LESS ROD	C NORMAL	C ACTUATED
8	1/2	10-32 UNF	.187 (.187)	.20	.17	1	2
7	3/4	1/8 NPSF	.250 (.250)	.44	.39	1 1/2	5
6	1 1/16	1/8 NPSF	.312 (.375)	.89	.81	4	8
25	1 1/4	1/8 NPSF	.437 (N.A.)	1.23	1.08	7	14
5	1 1/2	1/8 NPSF	.437 (.437)	1.77	1.62	6	12
75	1 3/4	1/4 NPSF	.500 (N.A.)	2.41	2.21	12	24
4	2	1/4 NPSF	.625 (N.A.)	3.14	2.84	15	30
3	2 1/2	1/4 NPSF	.625 (N.A.)	4.91	4.60	NA	NA

NOTE: For **Volume Chambers** please refer to page 162.  
 For **Special Rod Ends** please refer to pages 163-185.

# HOW TO ORDER

## BORE SIZES AVAILABLE BY MODEL

TYPE	DESCRIPTION	BORE SIZES AVAILABLE								RECOMMENDED MAXIMUM STROKE IN.	COMMENTS
		8	7	6	25	5	75	4	3		
		1/2 in.	3/4 in.	1 1/16 in.	1 1/4 in.	1 1/2 in.	1 3/4 in.	2 in.	2 1/2 in.		
S	Single Acting Nose Mount	•	•	•	•	•	•	•	•	6	All models Specify stroke in 1/8 inch increments as standard. Stroke tolerance ±1/32 in. Longer than standard stroke lengths are avail- able, consult factory. When specifying longer than standard strokes consider possible rod deflection, adequate lubrication, high speed friction, etc. No war- ranty applies.
SP	Single Acting Pivot Mount	•	•	•	•	•	•	•	•	6	
SH	Single Acting Nose Mount/Hex Rod	•	•	•		•				6	
SHP	Single Acting Pivot Mount/Hex Rod	•	•	•		•				6	
SR	Single Acting Reverse/Nose Mount	•	•	•	•	•	•	•		4	
SRP	Single Acting Reverse/Pivot Mount	•	•	•	•	•	•	•		4	
D	Double Acting Nose Mount	•	•	•	•	•	•	•	•	12	
DP	Double Acting Pivot/Double-End Mount	•	•	•	•	•	•	•	•	12	
D2EY	Double Acting Double End Rod	•	•	•	•	•	•	•	•	12	
BFS	Single Acting Block Front Mount	•	•	•		•				6	
BFSR	Single Acting Reverse/Block Front Mount	•	•	•		•				4	
BFD	Double Acting Block Front Mount	•	•	•		•				12	

## OPTIONS AVAILABLE BY MODEL

TYPE	DESCRIPTION	OPTIONS AVAILABLE													
		A	B	E	F	J	K	L	M	N	P	R	T	W	U
S	Single Acting Nose Mount	•	•	•	•						•				
SP	Single Acting Pivot Mount		•	•	•						•		•		•
SH	Single Acting Nose Mount/Hex Rod	•	•	•	•						•				
SHP	Single Acting Pivot Mount/Hex Rod		•	•	•						•		•		•
SR	Single Acting Reverse/Nose Mount	•	•	•	•	•	•	•		•	•			•	
SRP	Single Acting Reverse/Pivot Mount		•	•	•	•	•	•		•	•	•	•	•	•
D	Double Acting Nose Mount	•	•	•	•	•	•	•	•	•	•			•	
DP	Double Acting Pivot/Double-End Mount		•	•	•	•	•	•	•	•	•	•	•	•	•
D2EY	Double Acting Double End Rod			•	•	•	•	•	•		•			•	
BFS	Single Acting Block Front Mount	•	•	•	•	•	•	•			•				
BFSR	Single Acting Reverse/Block Front Mount	•	•	•	•	•	•	•		•	•				
BFD	Double Acting Block Front Mount	•	•	•	•	•	•	•	•	•	•				

# HOW TO ORDER OPTIONS

OPTIONS	DESCRIPTION
<b>A</b>	<b>SIDE PORTED REAR HEAD</b> Locates rear port on side of body on double or single acting models. (See below)
<b>B</b>	<b>BUMPER</b> Reduce mechanical noise. Absorb Shock. Negligible stroke change due to compression set. Buna N standard (Fluoroelastomer Bumpers standard when Option B is ordered with Option F). Single Acting Models—one bumper opposite spring side of piston. Double Acting Models—one bumper on both sides of piston. Standard on type D2EY. Option B & M ordered together—one bumper on rod end, magnet on head end of piston, also add 1/8 inch to desired stroke.
<b>E</b>	<b>LOW FRICTION SEALS</b> For low breakaway or low pressure applications.
<b>F</b>	<b>FLUOROCARBON SEALS (Fluoroelastomer)</b> For ambient temperatures of -20°F to 400°F (also consider heat generated by friction in high speed applications). For mild resistance to air line and ambient contaminants, fumes, compressor varnish, fire resistant lubricants, etc.
<b>J</b>	<b>ROTATE FRONT HEAD 90</b> Front head is rotated 90 degrees clockwise from rear port, viewed from rod end.
<b>K</b>	<b>ROTATE FRONT HEAD 180</b> Front head is rotated 180 degrees clockwise from rear port, viewed from rod end.
<b>L</b>	<b>ROTATE FRONT HEAD 270</b> Front head is rotated 270 degrees clockwise from rear port, viewed from rod end.
<b>M</b>	<b>INTERNAL MAGNET</b> For use with Humphrey Sensors. Available for Type D, DP, and BFD. (D2EY only models 7, 6, 25, 5). Option B (Bumpers) with Option M cylinders add 1/8 inch to desired stroke.
<b>N</b>	<b>WEARSTRIP</b> Protects piston and barrel from wear due to minor rod deflection. Standard on: Type D, DP, and BFD with 5 inches or more of stroke; Type SR and SRP with 3 inches or more of stroke. Not available on Model 8.
<b>P</b>	<b>POLYPAK ROD SEALS</b> provides excellent rod sealing capabilities at low pressures.
<b>R</b>	<b>ROTATED REAR PIVOT TANG</b> Rotation of rear pivot tang 90 degrees. Port remains in original position.
<b>T</b>	<b>PIVOT PIN IN REAR TANG</b> Pivot pin pressed into rear tang. No bracket available. Not available in Model 4 and 3.
<b>W</b>	<b>ROD WIPER</b> Provides a wiping action to remove most foreign material from exposed rod while maintaining adequate lubricating film. Protect rod and primary rod seal. Available on all Type D, DP, SR and D2EY models. Not available on Model 8.
<b>U</b>	<b>REAR PIVOT BUSHING</b> Bushing in rear pivot hole. Hole diameter remains the same. Available on SP, SHP, SRP, DP Models 7, 65, 25 STD on Model 3 + 4

## OPTION "A" DIMENSIONS

When ordering option "A", add dimension "G" to dimension "M" for overall length. ("M" dimension found on desired cylinder specification page).

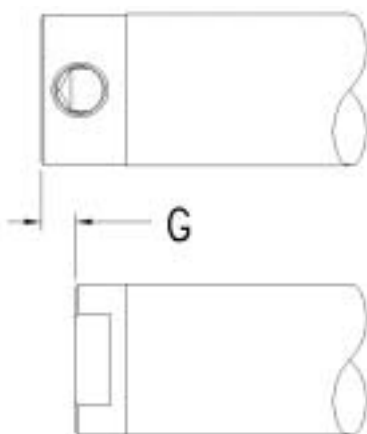

MODEL	G
<b>8</b>	.19
<b>7</b>	.44
<b>6</b>	.25
<b>25</b>	.31
<b>5</b>	.19
<b>75</b>	.56
<b>4</b>	.37
<b>3</b>	.37

SINGLE ACTING/NOSE MOUNT

# HUMPHREY AIR CYLINDERS

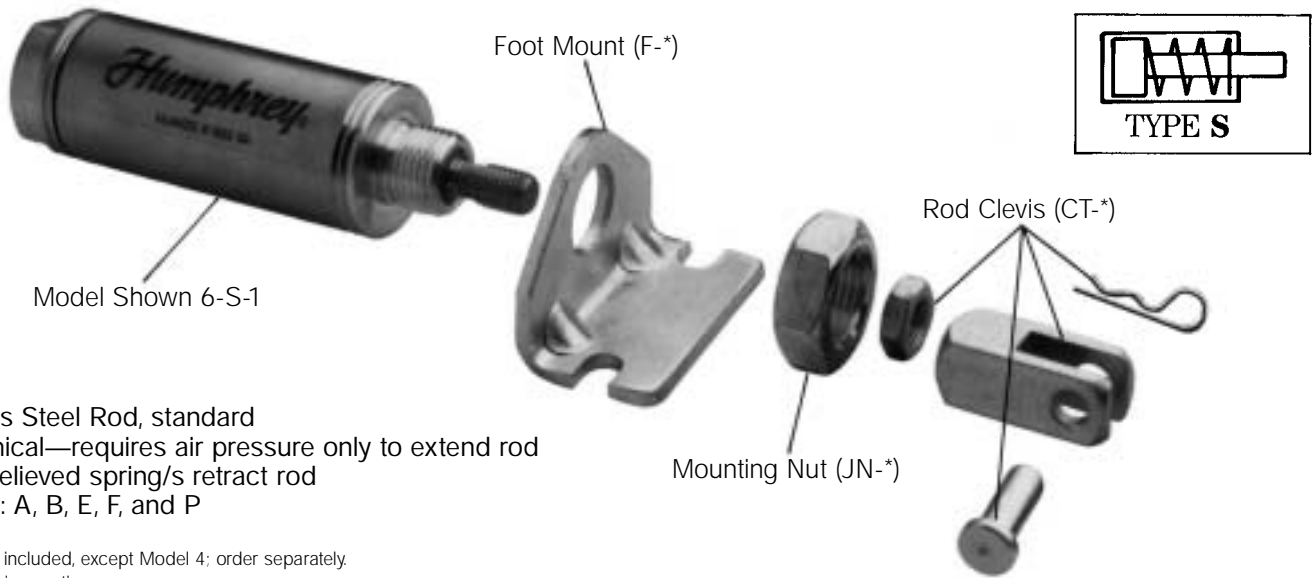

- Stainless Steel Rod, standard
- Economical—requires air pressure only to extend rod
- Stress relieved spring/s retract rod
- Options: A, B, E, F, and P

Mounting nut included, except Model 4; order separately.  
 \*See Accessories section.

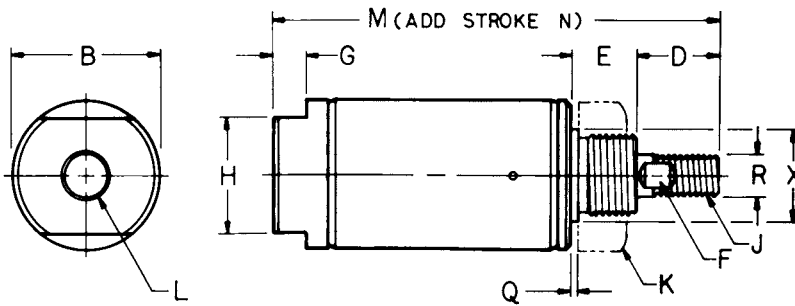

• No rod bushing, Model 8... front head is hard anodized.

Medium . . . . . Compressed Air  
 Pressure range . . . . . 0–200 PSIG  
 Temperature range . . . . . –40°F to  
 160°F Ambient\*  
 w/Fluoroelastomer . . . . . –20°F to 400°F  
 Ambient\*

Recommended maximum stroke . . . . . 6"

\*Additional heat may be generated by  
 seal friction (high speed cycling)

BASIC MODEL NO.	Piston Area SQ. IN.† Volume CU. IN. (per inch of stroke)	Spring Tension Pounds	
		Free	Comp.
8	.20	1	2
7	.44	1.5	5
6	.89	4	8
25	1.23	7	14
5	1.77	6	12
75	2.41	12	24
4	3.14	15	30

†Area x PSIG = Approximate Force

MODEL & TYPE (Stroke)	BORE	B Dia.	D Rod Exten.	E Nose Length	F Wrench Flat	G Flat	H Flat	J Rod Thread x Length	K Nose Thread	L Port (NPSF)	M Length	N			Q Pilot	R Rod Dia.	X Pilot Dia. –.001 –.006
												For each stroke increment of:	Add to M	For remaining stroke increment, Add to M, plus remaining stroke			
8-S-□	1/2	.56	.50	.31	None	.12	.37	10-32 x .50	3/8-24	10-32 UNF	1.81	1/2"	.94	.44	.04	.187	.375
7-S-□	3/4	.81	.50	.44	None	.16	.62	1/4-28 x .50	1/2-20	1/8	2.00	1"	1.69	.69	.07	.250	.500
6-S-□	1 1/16	1.12	.62	.50	.25	.25	.87	5/16-24 x .50	5/8-18	1/8	2.56	1"	1.56	.56	.07	.312	.625
25-S-□	1 1/4	1.31	1.00	.62	.38	.18	.87	7/16-20 x .75	3/4-16	1/8	3.41	1"	1.81	.81	.07	.437	.750
5-S-□	1 1/2	1.55	1.00	.62	.38	.25	.87	7/16-20 x .75	3/4-16	1/8	3.19	1"	1.69	.69	.07	.437	.750
75-S-□	1 3/4	1.81	1.19	.75	.44	.25	1.25	1/2-20 x .88	1-14	1/4	3.85	1"	2.00	1.00	.09	.500	1.030
4-S-□	2	2.07	1.25	.81	.50	.31	1.25	1/2-20 x .88	1 1/4-12	1/4	4.17	1"	2.00	1.00	.12	.625	1.375

SINGLE ACTING/PIVOT MOUNT or DOUBLE-END MOUNT

# HUMPHREY AIR CYLINDERS

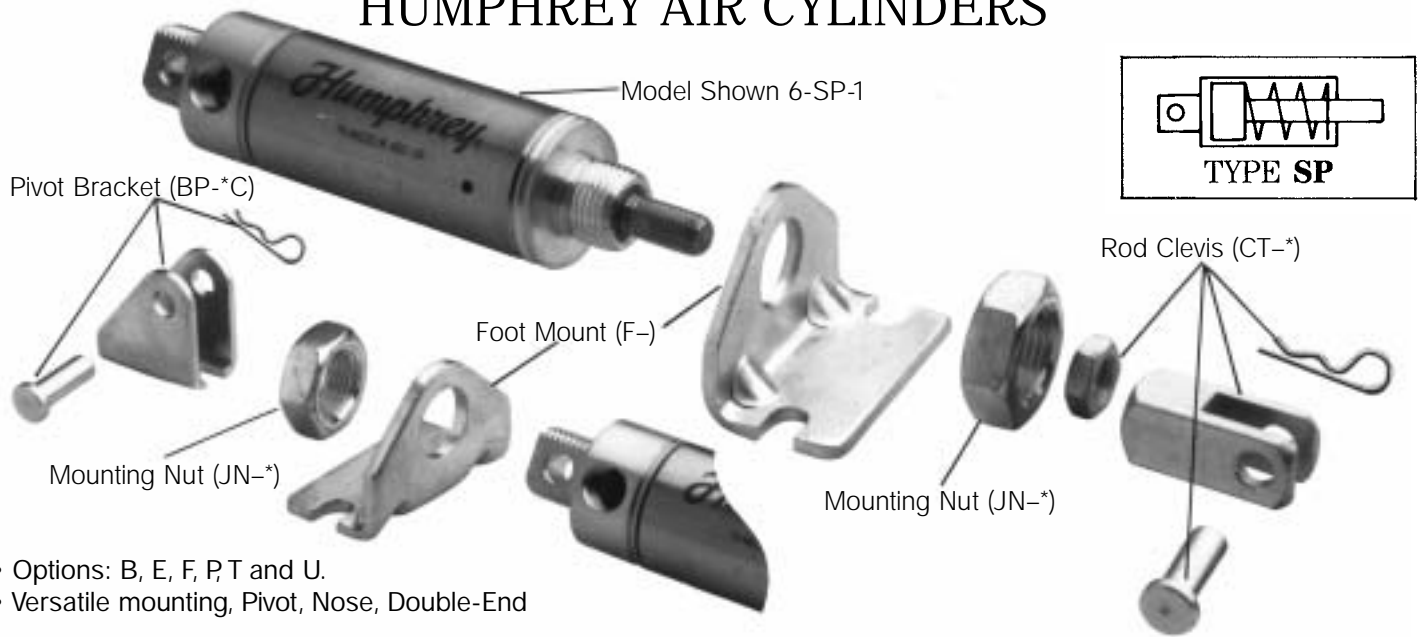

- Options: B, E, F, P, T and U.
- Versatile mounting, Pivot, Nose, Double-End

\*See Accessories section.

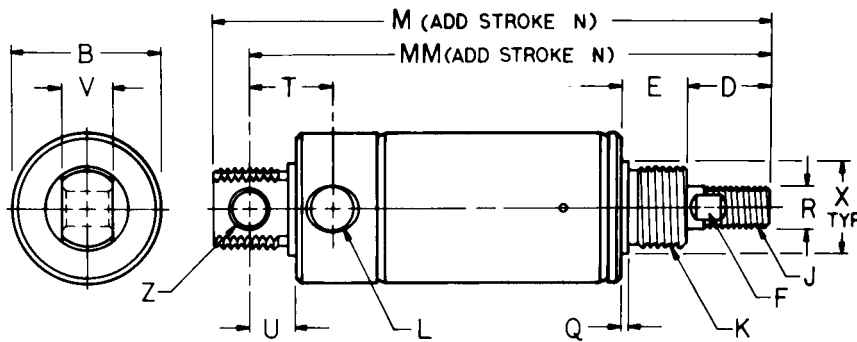

• No rod bushing. Model 8 ... front head is hard anodized.  
Model 4 has rear pivot bushing.

Medium ... Compressed Air  
Pressure range ... 0-200 PSIG  
Temperature range ... -40°F to 160°F Ambient\*  
w/Fluoroelastomer ... -20°F to 400°F Ambient\*

Recommended maximum stroke ... .6"

\*Additional heat may be generated by seal friction (high speed cycling)

BASIC MODEL NO.	Piston Area SQ. IN.† Volume CU. IN. (per inch of stroke)	Spring Tension Pounds	
		Free	Comp.
8	.20	1	2
7	.44	1.5	5
6	.89	4	8
25	1.23	7	14
5	1.77	6	12
75	2.41	12	24
4	3.14	15	30

†Area x PSIG = Approximate Force

MODEL & TYPE (Stroke)	BORE	B Dia.	D Rod Exten.	E Nose Length	F Wrench Flat	J Rod Thread x Length	K Nose Thread (Pivot Thread)	L Port (NPSF)	M Length	MM Length	N			Q Pilot	R Rod Dia.	T	U	V	X Pil. Dia. -.001 Front (Rear)	Z Pivot Hole Dia.
											For each stroke increment of:	Add to M & MM	For remaining stroke increment. Add to M, plus remaining stroke							
8-SP-□	1/2	.62	.50	.31	None	10-32 x .50	3/8-24 (7/16-20)	10-32 UNF	2.50	2.25	1/2"	.94	.44	.04	.187	.42	.25	.31	.375 (.437)	.16
7-SP-□	3/4	.81	.50	.44	None	1/4-28 x .50	1/2-20 (5/8-18)	1/8	3.06	2.77	1"	1.69	.69	.07	.250	.66	.34	.38	.500 (.625)	.25
6-SP-□	1 1/16	1.12	.62	.50	.25	5/16-24 x .50	5/8-18 TYP.	1/8	3.44	3.16	1"	1.56	.56	.07	.312	.62	.34	.38	.625	.25
25-SP-□	1 1/4	1.31	1.00	.62	.38	7/16-20 x .75	3/4-16 TYP.	1/8	4.50	4.14	1"	1.81	.81	.07	.437	.91	.41	.50	.750	.25
5-SP-□	1 1/2	1.55	1.00	.62	.38	7/16-20 x .75	3/4-16 TYP.	1/8	4.25	3.88	1"	1.69	.69	.07	.437	.81	.50	.62	.750	.38
75-SP-□	1 3/4	1.81	1.19	.75	.44	1/2-20 x .88	1-14 TYP.	1/4	5.41	4.91	1"	2.00	1.00	.09	.500	.98	.50	.62	1.030	.38
4-SP-□	2	2.07	1.25	.81	.50	1/2-20 x .88	1 1/4-12 TYP.	1/4	5.54	5.11	1"	2.00	1.00	.12	.625	1.0	.57	.75	1.375	.38†

SINGLE ACTING NON-ROTATING ROD/NOSE MOUNT

# HUMPHREY AIR CYLINDERS

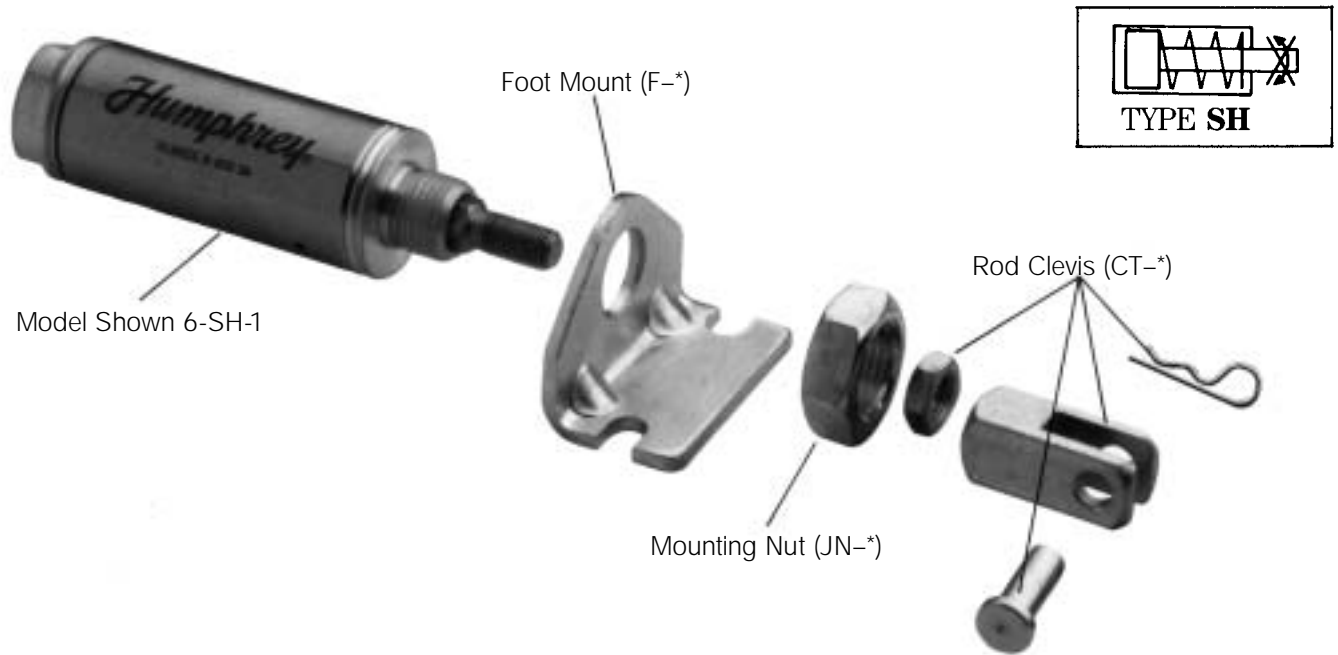

- Stainless Steel Rod, standard
- Non-rotating hex rod — no special guides required
- Requires air pressure only to extend rod

- Stress relieved spring/s retract rod
- Options: A, B, E, F and P

\*See Accessories section.

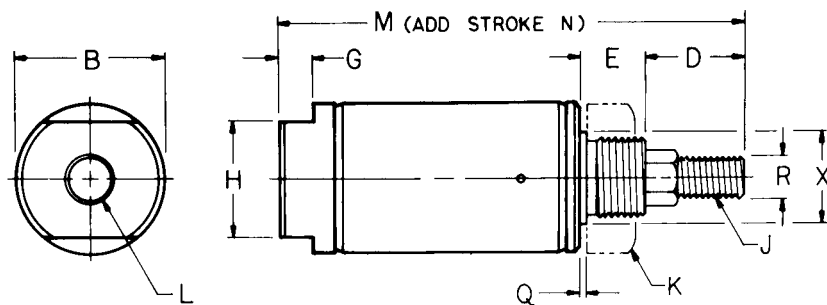

• No rod bushing, Type SH... front head hard anodized

Medium ..... Compressed Air  
 Pressure range ..... 0–200 PSIG  
 Temperature range ..... –40°F to 160°F Ambient\*  
 w/Fluoroelastomer ..... –20°F to 400°F Ambient\*

Recommended maximum stroke ..... .6"

\*Additional heat may be generated by seal friction (high speed cycling)

BASIC MODEL NO.	Piston Area SQ. IN.† Volume CU. IN. (per inch of stroke)	Spring Tension Pounds	
		Free	Comp.
8	.20	1	2
7	.44	1.5	5
6	.89	4	8
5	1.77	6	12

†Area x PSIG = Approximate Force

MODEL & TYPE (Stroke)	BORE	B Dia.	D Rod Exten.	E Nose Flat	G Flat	H Flat	J Rod Thread x Length	K Nose Thread	L Port (NPSF)	M Length	N			Q Pilot	R Rod Dia.	X Pilot Dia. –.001 –.006
											For each stroke increment of:	Add to M	For remaining stroke increment, Add to M, plus remaining stroke			
8-SH-□	1/2	.56	.75	.31	.12	.37	10-32 x .50	3/8-24	10-32 UNF	2.06	1/2"	.94	.44	.04	.187	.375
7-SH-□	3/4	.81	.75	.44	.16	.62	1/4-28 x .50	1/2-20	1/8	2.25	1"	1.69	.69	.07	.250	.500
6-SH-□	1 1/16	1.12	.75	.50	.25	.87	5/16-24 x .50	5/8-18	1/8	2.68	1"	1.56	.56	.07	.375	.625
5-SH-□	1 1/2	1.55	1.25	.62	.25	.87	7/16-20 x 1.0	3/4-16	1/8	3.44	1"	1.69	.69	.07	.437	.750

# HUMPHREY AIR CYLINDERS

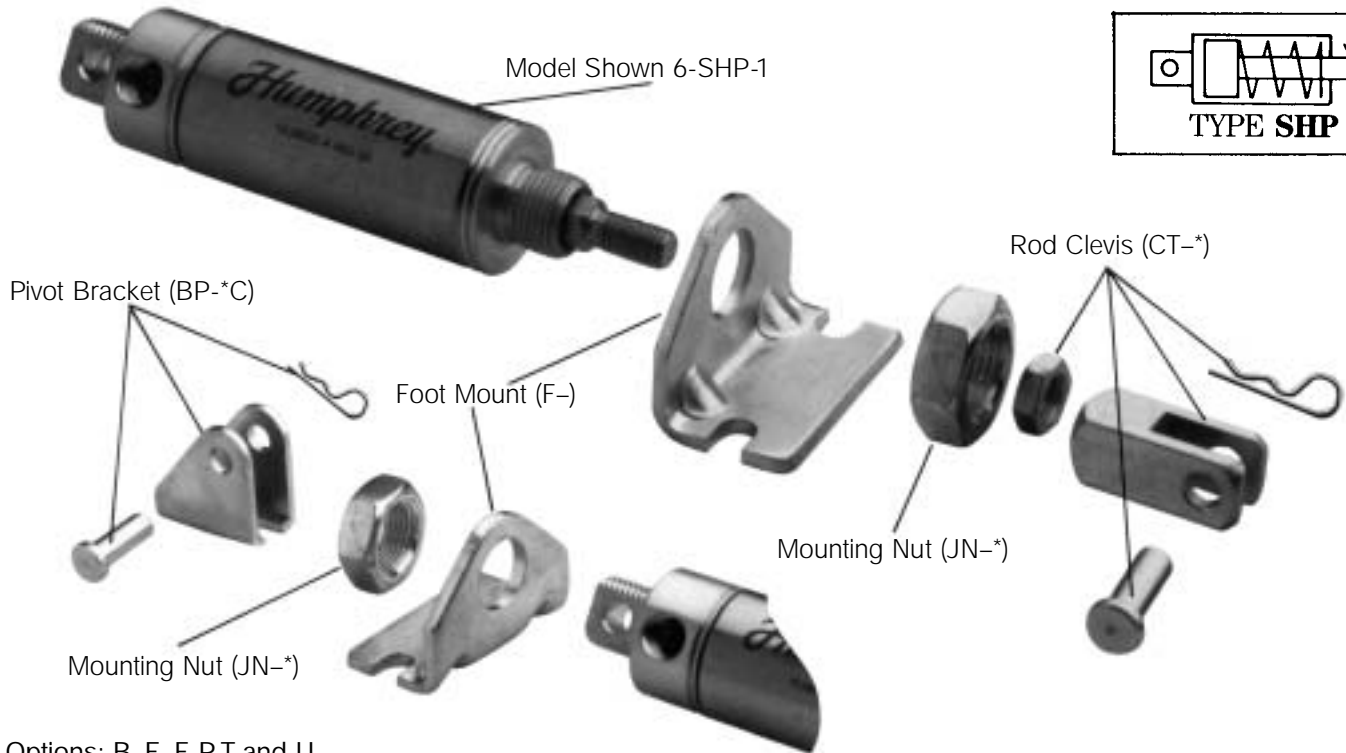
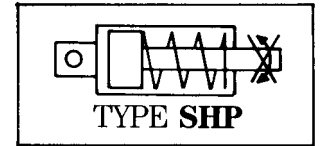

- Options: B, E, F, P, T and U.
- Versatile mounting, Pivot, Nose, Double-End

\*See Accessories section.

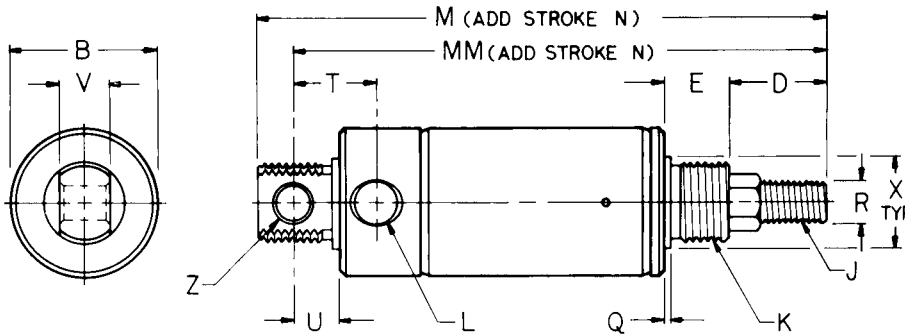

• No rod bushing, Type SHP...front hard anodized

Medium ..... Compressed Air  
 Pressure range ..... 0-200 PSIG  
 Temperature range ..... -40°F to 160°F Ambient\*  
 w/Fluoroelastomer ..... -20°F to 400°F Ambient\*

Recommended maximum stroke ..... .6"

\*Additional heat may be generated by seal friction (high speed cycling)

BASIC MODEL NO.	Piston Area SQ. IN.† Volume CU. IN. (per inch of stroke)	Spring Tension Pounds	
		Free	Comp.
8	.20	1	2
7	.44	1.5	5
6	.89	4	8
5	1.77	6	12

†Area x PSIG = Approximate Force

MODEL & TYPE (Stroke)	BORE	B Dia.	D Rod Exten.	E Nose Flat	J Rod Thread x Length	K Nose Thread (Pivot Thread)	L Port (NPSF)	M Length	MM Length	N		Q Pilot	R Hex Flats	T	U	V	X Pil. Dia. -.001 -.006 Front (Rear)	Z Pivot Hole Dia.	
										For each stroke increment	Add to M & MM For remaining stroke increment. Add to M, plus remaining stroke								
8-SHP-□	1/2	.56	.75	.31	10-32 x .50	3/8-24	10-32 UNF	2.75	2.50	1/2"	.94	.44	.04	.187	.42	.25	.31	.375 (437)	.16
7-SHP-□	3/4	.81	.75	.44	1/4-28 x .50	1/2-20 (3/8-18)	1/8	3.31	3.02	1"	1.69	.69	.07	.250	.66	.34	.38	.500 (.625)	.25
6-SHP-□	1 1/16	1.12	.75	.50	5/16-24 x .50	5/8-18	1/8	3.56	3.28	1"	1.56	.56	.07	.375	.62	.34	.38	.625	.25
5-SHP-□	1 1/2	1.55	1.25	.62	7/16-20 x 1.0	3/4-16	1/8	4.50	4.13	1"	1.69	.69	.07	.437	.81	.50	.62	.750	.38

# SINGLE ACTING REVERSE/NOSE MOUNT HUMPHREY AIR CYLINDERS



Model Shown 6-SR-1

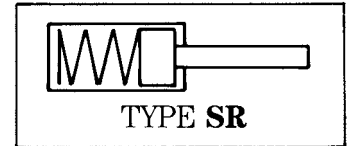

Foot Mount (F-\*)

Rod Clevis (CT-\*)

Mounting Nut (JN-\*)

- Stainless Steel Rod, standard
- Requires air pressure to retract rod
- Stress relieved spring/s extend rod
- Options: A, B, E, F, J, K, L, N, P, W
- Wearstrip standard: 3 inches or more of stroke (optional, shorter strokes)
- Mounting nut included, except Model 4, order separately.

\*See Accessories section.

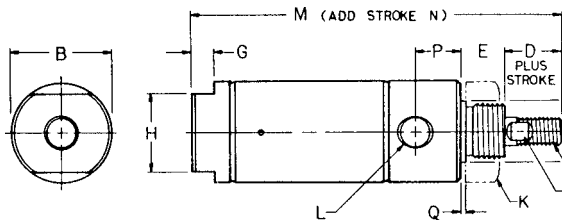

Medium . . . . . Compressed Air  
 Pressure range . . . . . 0-200 PSIG  
 Temperature range . . . . . -40°F to 160°F Ambient\*  
 w/Fluoroelastomer . . . . . -20°F to 400°F Ambient\*  
 Recommended maximum stroke . . . . . 4"  
 \*Additional heat may be generated by seal friction (high speed cycling)

BASIC MODEL NO.	Piston Area SQ. IN.† Volume CU. IN. (per inch of stroke)	Spring Tension Pounds	
		Free	Comp.
8	.17	1	4
7	.39	1.5	7.5
6	.81	4	12
25	1.08	7	21
5	1.62	6	18
75	2.21	12	36
4	2.84	15	42

†Area x PSIG = Approximate Force

• No rod bushing, Model 8 . . . front hard anodized

MODEL & TYPE (Stroke)	BORE	B Dia.	D Rod Retracted	E Nose Length	F Wrench Flat	G Flat	H Flat	J Rod Thread x Length	K Nose Thread	L Port (NPSF)	M Length (w/rod extended)	N			P	Q	R Rod Dia.	X Pilot Dia. -.001 -.006
												For each stroke increment of:	Add to M	For remaining stroke increment Add M plus remaining stroke				
8-SR-□	1/2	.62	.50	.41	None	.12	.37	10-32 x .50	7/16-20	10-32 UNF	2.42	1/2"	1.44	.94	.37	.04	.187	.437
7-SR-□	3/4	.88	.50	.50	None	.16	.62	1/4-28 x .50	5/8-18	1/8	2.78	1"	2.69	1.69	.48	.07	.250	.625
6-SR-□	1 1/16	1.12	.62	.50	.25	.25	.87	5/16-24 x .50	5/8-18	1/8	3.28	1"	2.56	1.56	.52	.07	.312	.625
25-SR-□	1 1/4	1.31	1.00	.62	.38	.18	.87	7/16-20 x .75	3/4-16	1/8	4.25	1"	2.81	1.81	.63	.07	.437	.750
5-SR-□	1 1/2	1.55	1.00	.62	.38	.25	.87	7/16-20 x .75	3/4-16	1/8	4.00	1"	2.69	1.69	.62	.07	.437	.750
75-SR-□	1 3/4	1.81	1.19	.75	.44	.25	1.25	1/2-20 x .88	1-14	1/4	5.03	1"	3.00	2.00	.72	.09	.500	1.030
4-SR-□	2	2.07	1.25	.81	.50	.31	1.25	1/2-20 x .88	1 1/4-12	1/4	5.11	1"	3.00	2.00	.69	.12	.625	1.375

SINGLE ACTING REVERSE/PIVOT MOUNT or DOUBLE-END MOUNT

# HUMPHREY AIR CYLINDERS

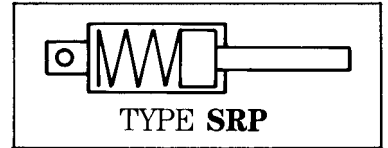

- Options: B, E, F, J, K, L, N, P, R, T, W, U.
- Versatile mounting, Pivot, Nose, Double-End

\*See Accessories section.

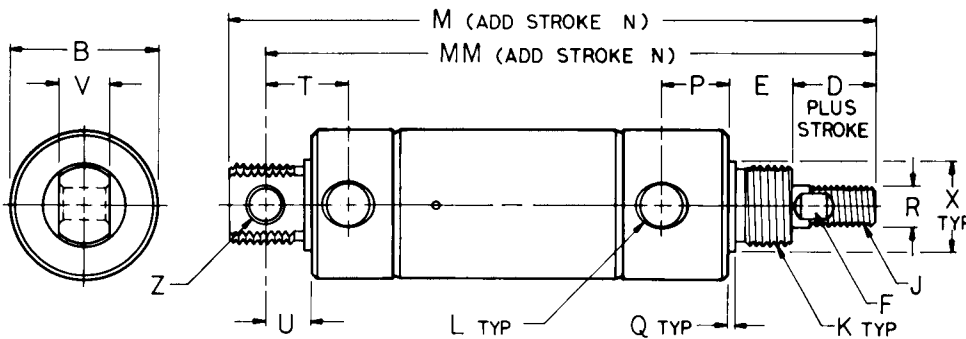

• No rod bushing. Model 8 ... front head is hard anodized.  
Model 4 has rear pivot bushing.

Medium ..... Compressed Air  
Pressure range ..... 0-200 PSIG  
Temperature range ..... -40°F to 160°F Ambient\*  
w/Fluoroelastomer ..... -20°F to 400°F Ambient\*

Recommended maximum stroke ..... 4"

\*Additional heat may be generated by seal friction (high speed cycling)

BASIC MODEL NO.	Piston Area SQ. IN.† Volume CU. IN. (per inch of stroke)	Spring Tension Pounds	
		Free	Comp.
8	.17	1	4
7	.39	1.5	7.5
6	.81	4	12
25	1.08	7	21
5	1.62	6	18
75	2.21	12	36
4	2.84	15	42

†Area x PSIG = Approximate Force

MODEL & TYPE (Stroke)	BORE	B Dia.	D Rod Retr.	E Nose Length	F Wrench Flat	J Rod Thread x Length	K Nose & Pivot Thread	L Port (NPSF)	M Length (w/rod extended)	MM Length (w/rod extended)	N			P	Q Pilot	R Rod Dia.	T	U	V	X Pil. Dia. -.001-.005	Z Pivot Hole Dia.
											For each stroke increment of:	Add to M & MM	For remaining stroke length, add to M plus remaining stroke								
8-SRP-□	1/2	.62	.50	.41	None	10-32 x .50	7/16-20	10-32 UNF	3.12	2.88	1/2"	1.44	.94	.37	.04	.187	.42	.25	.31	.437	.16
7-SRP-□	3/4	.88	.50	.50	None	1/4-28 x .50	5/8-18	1/8	3.84	3.55	1"	2.69	1.69	.48	.07	.250	.66	.34	.38	.625	.25
6-SRP-□	1 1/16	1.12	.62	.50	.25	5/16-24 x .50	5/8-18	1/8	4.15	3.87	1"	2.56	1.56	.52	.07	.312	.62	.34	.38	.625	.25
25-SRP-□	1 1/4	1.31	1.00	.62	.38	7/16-20 x .75	3/4-16	1/8	5.33	4.97	1"	2.81	1.81	.63	.07	.437	.91	.41	.50	.750	.25
5-SRP-□	1 1/2	1.55	1.00	.62	.38	7/16-20 x .75	3/4-16	1/8	5.06	4.69	1"	2.69	1.69	.62	.07	.437	.81	.50	.62	.750	.38
75-SRP-□	1 3/4	1.81	1.19	.75	.44	1/2-20 x .88	1-14	1/4	6.59	6.09	1"	3.00	2.00	.72	.09	.500	.98	.50	.62	1.030	.38
4-SRP-□	2	2.07	1.25	.81	.50	1/2-20 x .88	1 1/4-12	1/4	6.48	6.05	1"	3.00	2.00	.69	.12	.625	1.0	.57	.75	1.375	.38

DOUBLE ACTING/NOSE MOUNT

# HUMPHREY AIR CYLINDERS



Model Shown 6-D-1

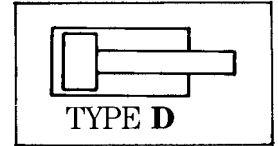

Foot Mount (F-\*)

Rod Clevis (CT-\*)

Mounting Nut (JN-\*)

- Stainless Steel Rod, standard
- Simple, reliable design
- Requires air pressure to extend *and* retract rod
- *Extend* force exceeds *retract* force (smaller effective area on rod side of piston)
- Exclusive Humphrey Reversible Piston
- Specify Option M (Internal Magnet) to operate sensors
- Wearstrip standard: 5 inches or more of stroke (optional, shorter strokes N/A on model 8)
- Options: A, B, E, F, J, K, L, M, N, P, W

Mounting Nut included, except Model 4 & 3: order separately.

\*See Accessories section.

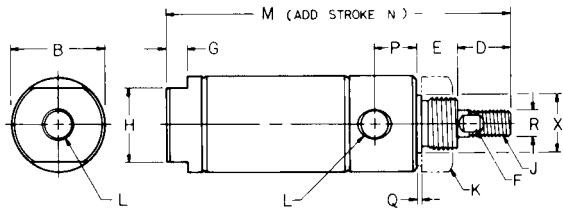

• No rod bushing. Model 8... front hard anodized

Medium..... Compressed Air  
 Pressure range ..... 0-200 PSIG  
 Temperature range ..... -40°F to 160°F Ambient\*  
 w/Fluoroelastomer..... -20°F to 400°F Ambient\*  
 Recommended maximum stroke..... 12"

\*Additional heat may be generated by seal friction (high speed cycling)

BASIC MODEL NO.	Piston Area SQ. IN.† Volume CU. IN. (per inch of stroke)		Rod Side
	Plain Side		
8	.20		.17
7	.44		.39
6	.89		.81
25	1.23		1.08
5	1.77		1.62
75	2.41		2.21
4	3.14		2.84
3	4.91		4.60

†Area x PSIG = Approximate Force

MODEL & TYPE (Stroke)	BORE	B Dia.	D Rod Exten.	E Nose Length	F Wrench Flat	G Flat	H Flat	J Rod Thread x Length	K Nose Thread	L Port (NPSF)	M Length	N		P	O Pilot	R Rod Dia.	X Pilot Dia. -.001 -.006
												For each stroke increment of:	Add to M				
8-D-□	1/2	.62	.50	.41	None	.12	.37	10-32 x .50	7/16-20	10-32 UNF	2.62*	1/2"	.50	.37	.04	.187	.437
7-D-□	3/4	.88	.50	.50	None	.16	.62	1/4-28 x .50	5/8-18	1/8	3.47	1"	1.00	.48	.07	.250	.625
6-D-□	1 1/16	1.12	.62	.50	.25	.25	.87	5/16-24 x .50	5/8-18	1/8	3.75	1"	1.00	.52	.07	.312	.625
25-D-□	1 1/4	1.31	1.00	.62	.38	.18	.87	7/16-20 x .75	3/4-16	1/8	4.75	1"	1.00	.63	.07	.437	.750
5-D-□	1 1/2	1.55	1.00	.62	.38	.25	.87	7/16-20 x .75	3/4-16	1/8	4.44	1"	1.00	.62	.07	.437	.750
75-D-□	1 3/4	1.81	1.19	.75	.44	.25	1.25	1/2-20 x .88	1-14	1/4	5.57	1"	1.00	.72	.09	.500	1.030
4-D-□	2	2.07	1.25	.81	.50	.31	1.25	1/2-20 x .88	1 1/4-12	1/4	5.56	1"	1.00	.69	.12	.625	1.375
3-D-□	2 1/2	2.62	1.25	.81	.50	.31	1.75	1/2-20 x .88	1 3/8-12	1/4	5.56	1"	1.00	.69	.12	.625	1.500

\*Add 0.399 for Option M.

DOUBLE ACTING/PIVOT MOUNT or DOUBLE-END MOUNT

# HUMPHREY AIR CYLINDERS

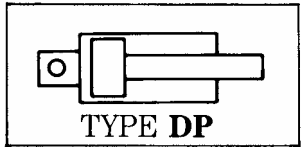

- Options: B, E, F, J, K, L, M, N, P, R, T, W, U.
- Versatile mounting, Pivot, Nose, Double-End

\*See Accessories section.

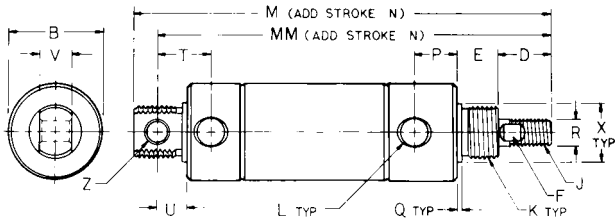

Medium . . . . . Compressed Air  
 Pressure range . . . . . 0-200 PSIG  
 Temperature range . . . . . -40°F to 160°F Ambient\*  
 w/Fluoroelastomer . . . . . -20°F to 400°F Ambient\*  
 Recommended maximum stroke . . . . . .12"

\*Additional heat may be generated by seal friction (high speed cycling)

BASIC MODEL NO.	Piston Area SQ. IN.† Volume CU. IN. (per inch of stroke)	
	Plain Side	Rod Side
8	.20	.17
7	.44	.39
6	.89	.81
25	1.23	1.08
5	1.77	1.62
75	2.41	2.21
4	3.14	2.84
3	4.91	4.60

†Area x PSIG = Approximate Force

• No rod bushing, Model 8 . . . front head is hard anodized. Models 3 & 4 have rear pivot bushing.

MODEL & TYPE (Stroke)	BORE	B Dia.	D Rod Exten.	E Nose Length	F Wrench Flat	J Rod Thread x Length	K Nose & Pivot Thread	L Port (NPSF)	M Length	MM Length	N		P	Q Pilot	R Rod Dia.	T	U	V	X Pilot Dia. -.001 -.006	Z Pivot Hole Dia.
											For each stroke increment of:	Add to MM								
8-DP-□	1/2	.62	.50	.41	None	10-32 x .50	7/16-20	10-32 UNF	3.31*	3.06*	1/2"	.50	.37	.04	.187	.42	.25	.31	.437	.16
7-DP-□	3/4	.88	.50	.50	None	1/4-28 x .50	5/8-18	1/8	4.54	4.25	1"	1.0	.48	.07	.250	.66	.34	.38	.625	.25
6-DP-□	1 1/16	1.12	.62	.50	.25	5/16-24 x .50	5/8-18	1/8	4.62	4.34	1"	1.0	.52	.07	.312	.62	.34	.38	.625	.25
25-DP-□	1 1/4	1.31	1.00	.62	.38	7/16-20 x .75	3/4-16	1/8	5.83	5.47	1"	1.0	.63	.07	.437	.91	.41	.50	.750	.25
5-DP-□	1 1/2	1.55	1.00	.62	.38	7/16-20 x .75	3/4-16	1/8	5.50	5.12	1"	1.0	.62	.07	.437	.81	.50	.62	.750	.38
75-DP-□	1 3/4	1.81	1.19	.75	.44	1/2-20 x .88	1-14	1/4	7.13	6.63	1"	1.0	.72	.09	.500	.98	.50	.62	1.030	.38
4-DP-□	2	2.07	1.25	.81	.50	1/2-20 x .88	1 1/4-12	1/4	6.93	6.50	1"	1.0	.69	.12	.625	1.0	.57	.75	1.375	.38
3-DP-□	2 1/2	2.62	1.25	.81	.50	1/2-20 x .88	1 3/8-12	1/4	6.93	6.50	1"	1.0	.69	.12	.625	1.0	.57	.75	1.500	.38

\*Model 8 only — add 0.399 for Option M.

DOUBLE ACTING DOUBLE-END ROD/DOUBLE-END MOUNT

HUMPHREY AIR CYLINDERS

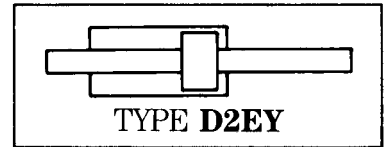

Foot Mount (F-\*)

Rod Clevis (CT-\*)

Mounting Nut (JN-\*)

- Air pressure produces equal force in both directions due to equal piston area; permits "locking" in mid-stroke
- One rod can be used to perform a work function, second rod to operate limit switches, provide support or guide
- Fixed mounting of both rod ends allows movement of barrel only
- Bumpers and Stainless Steel Rod, standard
- Options: E, F, J, K, L, M, P, W
- Two mounting nuts included, except Model 3 & 4; order separately.

\*See Accessories section.

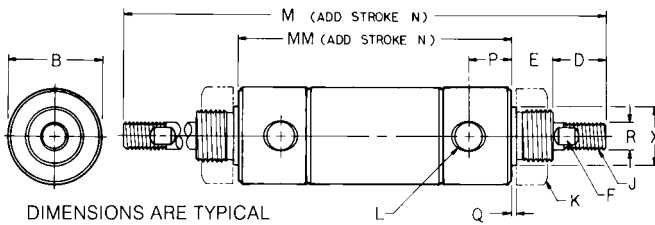

DIMENSIONS ARE TYPICAL

• No rod bushing, Model 8... heads hard anodized.

Medium ..... Compressed Air  
 Pressure range. .... 0-200 PSIG  
 Temperature range ..... -40°F to 160°F Ambient\*  
 w/Fluoroelastomer ..... -20°F to 400°F Ambient\*  
 Recommended maximum stroke ..... 12"

\*Additional heat may be generated by seal friction (high speed cycling)

BASIC MODEL NO.	Piston Area SQ. IN.†	
	Volume CU. IN. (per inch of stroke)	
8	.17	
7	.39	
6	.81	
25	1.08	
5	1.62	
75	2.21	
4	2.84	
3	4.60	

†Area x PSIG = Approximate Force

MODEL & TYPE (Stroke)	BORE	B Dia.	D Rod Exten.	E Nose Length	F Wrench Flat	J Rod Thread x Length	K Nose Thread	L Port (NPSF)	M Length	MM Length	N		P (Typical)	Q Pilot	R Rod Dia.	X Pilot Dia. -.001 -.006	
											For each stroke increment of:	Add to					
												M					MM
8-D2EY-□	1/2	.62	.50	.41	None	10-32 x .50	7/16-20	10-32 UNF	3.88	2.07	1/2"	1.00	.50	.37	.04	.187	.437
7-D2EY-□	3/4	.88	.50	.50	None	1/4-28 x .50	5/8-18	1/8	5.03	3.03	1"	2.00	1.00	.48	.07	.250	.625
6-D2EY-□	1 1/16	1.12	.62	.50	.25	5/16-24 x .50	5/8-18	1/8	5.32	3.07	1"	2.00	1.00	.52	.07	.312	.625
25-D2EY-□	1 1/4	1.31	1.00	.62	.38	7/16-20 x .75	3/4-16	1/8	6.83	3.58	1"	2.00	1.00	.63	.07	.437	.750
5-D2EY-□	1 1/2	1.55	1.00	.62	.38	7/16-20 x .75	3/4-16	1/8	6.63	3.39	1"	2.00	1.00	.62	.07	.437	.750
75-D2EY-□	1 3/4	1.81	1.19	.75	.44	1/2-20 x .88	1-14	1/4	8.57	4.69	1"	2.00	1.00	.72	.09	.500	1.030
4-D2EY-□	2	2.07	1.25	.81	.50	1/2-20 x .88	1 1/4-12	1/4	8.31	4.19	1"	2.00	1.00	.69	.12	.625	1.375
3-D2EY-□	2 1/2	2.62	1.25	.81	.50	1/2-20 x .88	1 3/8-12	1/4	8.31	4.19	1"	2.00	1.00	.69	.12	.625	1.500

# SINGLE ACTING AND SINGLE ACTING REVERSE/BLOCK FRONT MOUNT

Model Shown 6-BFS-1

## HUMPHREY AIR CYLINDERS

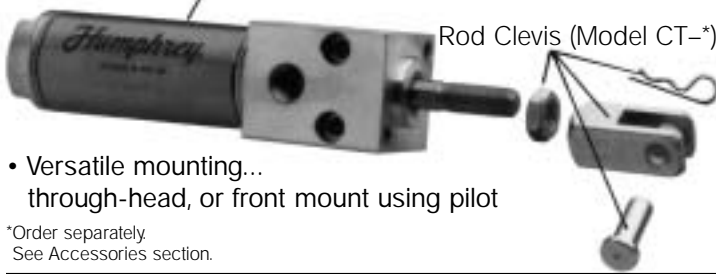

- Versatile mounting... through-head, or front mount using pilot

- Stainless Steel Rod, standard
- Wearstrip standard BFSRs with stroke  $\geq 39$  (N/A. on model 8)
- Options: A, B, E, F, J, K, L, P

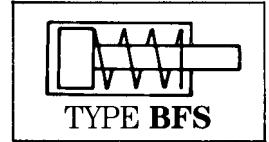

\*Order separately. See Accessories section.

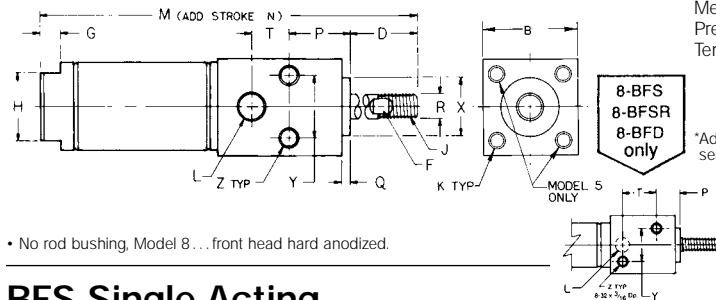

Medium Compressed Air  
 Pressure range 0-200 PSIG  
 Temperature range -40°F to 160°F Ambient\*  
 w/Fluoroelastomer -20°F to 400°F Ambient\*

\*Additional heat may be generated by seal friction (high speed cycling)

BASIC MODEL NO.	Piston Area SQ. IN.†		Spring Tension Pounds	
	Volume CU. IN. (per inch of stroke)		Free	Comp.
8-BFS	.20		1	2
7-BFS	.44		1.5	5
6-BFS	.89		4	8
5-BFS	1.77		6	12
8-BFSR	.17		1	4
7-BFSR	.39		1.5	7.5
6-BFSR	.81		4	12
5-BFSR	1.62		6	18

†Area x PSIG = Approximate Force

• No rod bushing, Model 8... front head hard anodized.

### BFS Single Acting

MODEL & TYPE (Stroke)	BORE	B Square	D Rod Exten.	F Wrench Flat	G Flat	H Flat	J Rod Thread x Length	K Mounting Holes	L Port (NPSF)	M Length	N			P	Q Pilot	R Rod Dia.	T	X Pilot Dia. -.001 -.006	Y	Z Mounting Holes
											For each stroke increment of:	Add to M	For remaining stroke increment, Add to M, plus remaining stroke							
8-BFS-□	1/2	.75	.50	None	.12	.37	10-32 x .50	Two #8-32 holes on .75 diameter bolt circle	10-32 UNF	2.42	1/2"	.94	.44	.31	.06	.187	.44	.437	.44	Two #8-32 holes
7-BFS-□	3/4	1.00	1.06	.22	.16	.62	1/4-28 x .75	Two #10-32 holes on 1.0 diameter bolt circle	1/8	3.34	1"	1.69	.69	.48	.09	.250	.51	.625	.62	Two holes drill and c' bored for 10-32 cap screw tap 1/4-20
6-BFS-□	1 1/16	1.25	1.12	.25	.25	.87	5/16-24 x .50	Two #10-32 holes on 1.25 diameter bolt circle	1/8	4.28	1"	1.56	.56	.72	.09	.312	.54	.750	.81	Two holes drill and c' bored for 10-32 cap screw tap 1/4-20
5-BFS-□	1 1/2	1.75	1.50	.38	.25	.87	7/16-20 x 1.25	Four 1/4-20 holes on 1.75 diameter bolt circle	1/4	5.00	1"	1.69	.69	1.00	.12	.437	.66	1.000	112	Two holes drill and c'bored for 1/4-20 cap screw tap 5/16-18

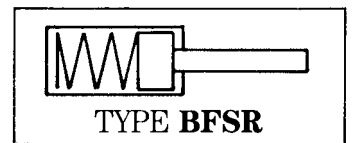

### BFSR Single Acting Reverse

MODEL & TYPE (Stroke)	BORE	B Square	D Rod Re-tracted	F Wrench Flat	G Flat	H Flat	J Rod Thread x Length	K Mounting Holes	L Port (NPSF)	M Length (w/rod extended)	N			P	Q Pilot	R Rod Dia.	T	X Pilot Dia. -.001 -.006	Y	Z Mounting Through Holes
											For each stroke increment of:	Add to M	For remaining stroke increment, Add to M, plus remaining stroke							
8-BFSR-□	1/2	.75	.50	None	.12	.37	10-32 x .50	Two #8-32 holes on .75 diameter bolt circle	10-32 UNF	2.42	1/2"	1.44	.94	.31	.06	.187	.44	.437	.44	Two #8-32 holes
7-BFSR-□	3/4	1.00	1.06	.22	.16	.62	1/4-28 x .75	Two #10-32 holes on 1.0 diameter bolt circle	1/8	3.34	1"	2.69	1.69	.48	.09	.250	.51	.625	.62	Two holes drilled and c' bored for 10-32 cap screw tap 1/4-20
6-BFSR-□	1 1/16	1.25	1.12	.25	.25	.87	5/16-24 x .50	Two #10-32 holes on 1.25 diameter bolt circle	1/8	4.28	1"	2.56	1.56	.72	.09	.312	.54	.750	.81	Two holes drilled and c' bored for 10-32 cap screw tap 1/4-20
5-BFSR-□	1 1/2	1.75	1.50	.38	.25	.87	7/16-20 x 1.25	Four 1/4-20 holes on 1.75 diameter bolt circle	1/4	5.18	1"	2.69	1.69	1.00	.12	.437	.66	1.000	112	Two holes drilled and c'bored for 1/4-20 cap screw tap 5/16-18

# DOUBLE ACTING/BLOCK FRONT MOUNT HUMPHREY AIR CYLINDERS

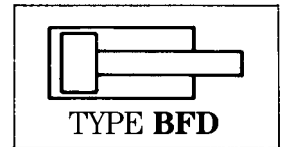
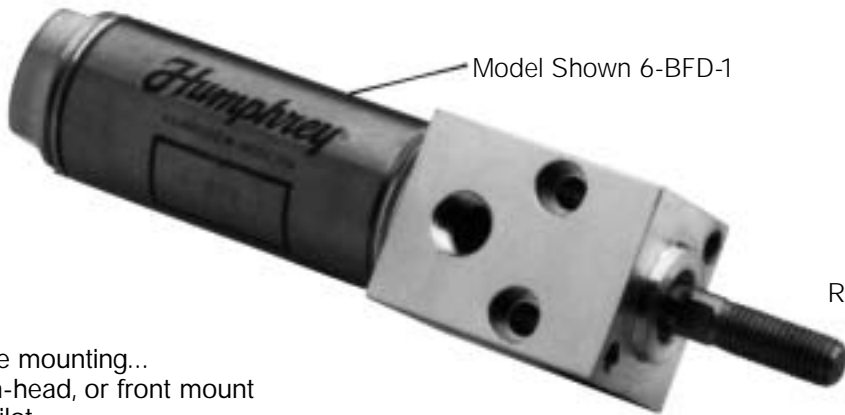

Rod Clevis (Model CT-\*)



- Versatile mounting... through-head, or front mount using pilot
- Stainless Steel Rod, standard
- Wearstrip standard (Double acting only): 5 inches or more of stroke (Optional, shorter strokes)
- Options: A, B, E, F, J, K, L, M, N, P

\*Order separately. See Accessories section.

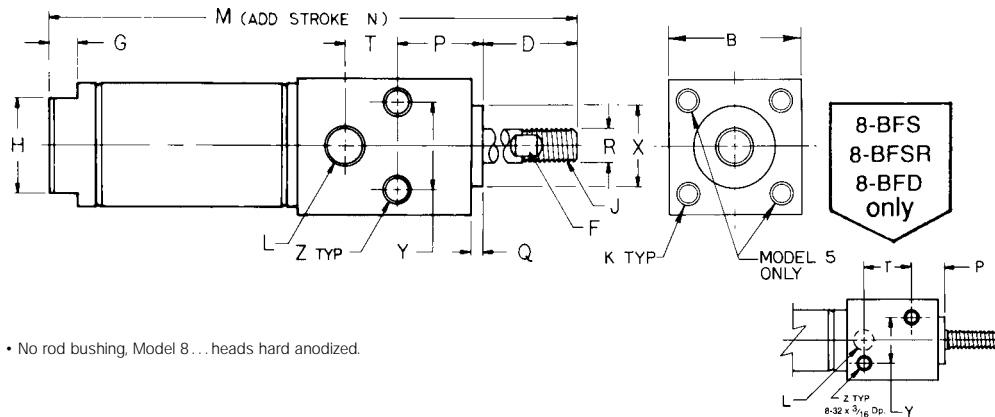

• No rod bushing, Model 8... heads hard anodized.

Medium ..... Compressed Air  
 Pressure range ..... 0-200 PSIG  
 Temperature range ..... -40°F to 160°F Ambient\*  
 w/Fluoroelastomer ..... -20°F to 400°F Ambient\*

\*Additional heat may be generated by seal friction (high speed cycling)

BASIC MODEL	Piston Area SQ. IN.† Volume CU. IN. (per inch of stroke)	
	Plain Side	Rod Side
8-BFD	.20	.17
7-BFD	.44	.39
6-BFD	.89	.81
5-BFD	1.77	1.62

†Area x PSIG = Approximate Force

MODEL & TYPE (Stroke)	BORE	B Square	D Rod Exten.	F Wrench Flat	G Flat	H Flat	J Rod Thread x Length	K Mounting Holes	L Port (NPSF)	M Length	N		P	Q Pilot	R Rod Dia.	T	X Pilot Dia. -.001 -.006	Y	Z Mounting Through Holes
											For each stroke increment of	Add to M							
8-BFD-□	1/2	.75	.50	None	.12	.37	10-32 x .50	Two #8-32 holes on .75 diameter bolt circle	10-32 UNF	2.62	1/2"	.50	.31	.06	.187	.44	.437	.44	Two #8-32 holes
7-BFD-□	3/4	1.00	1.06	.22	.16	.62	1/4-28 x .75	Two #10-32 holes on 1.0 diameter bolt circle	1/8	4.03	1"	1.0	48	.09	.250	.51	.625	.62	Two holes drill and c' bored for 10-32 cap screw tap 1/4-20
6-BFD-□	1 1/16	1.25	1.12	.25	.25	.87	5/16-24 x .50	Two #10-32 holes on 1.25 diameter bolt circle	1/8	4.75	1"	1.0	.72	.09	.312	.54	.750	.81	Two holes drill and c' bored for 10-32 cap screw tap 1/4-20
5-BFD-□	1 1/2	1.75	1.50	.38	.25	.87	7/16-20 x 1.25	Four 1/4-20 holes on 1.75 diameter bolt circle	1/4	5.44	1"	1.0	100	.12	.437	.66	1.000	112	Two holes drill and c' bored for 1/4-20 cap screw tap 5/16-18

# ACCESSORIES

## HUMPHREY AIR CYLINDERS

- Air Cylinder Accessories are made of carbon steel • Burnished for surface smoothness
- Bright zinc plated for corrosion resistance

### PIVOT BRACKET

- For use with Pivot cylinders
- Cylinders can Pivot through 120°
- One-piece construction for Strength, and ease of cylinder installation/removal
- Pivot pin and cotter pin supplied (Available separately... order by part number)

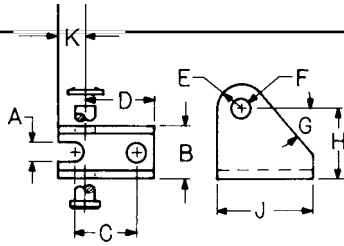

Note: previously cataloged cylinders used two-piece Model BP-Pivot Bracket

Accessory NUMBER	Cylinder Bore Sizes & MODELS	A	B	C	D	E	F	G	H	J	K
BP-8-C	1/2 (8)	.20	.52	.43	.54	.22	.16	50°	.64	.75	.156
BP-11-C	3/4 (7) & 1 1/16 (6)	.26	.65	.75	.87	.31	.26	53°	.87	1.19	.218
BP-25-C	1 1/4 (25)	.32	.77	.75	.94	.31	.26	53°	1.06	1.25	.250
BP-15-C	1 1/2 (5) & 1 3/4 (75)	.39	.96	1.00	1.25	.38	.38	52°	1.37	1.63	.317
BP-19-C	2 (4) & 2 1/2 (3)	.45	1.20	1.00	1.43	.38	.38	48°	1.68	1.81	.406

### ROD CLEVIS

- For use on all cylinders
- Smooth beveled ends
- Locknut, clevis pin and cotter pin (Available separately... order by part number)

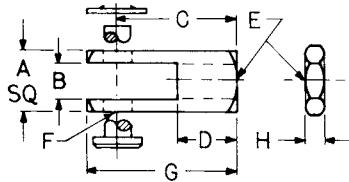

CT-8	1/2 (8)	.38	.19	.75	.38	10-32	.19	.94	.12		
CT-7 3/4 (7)	.50	.25	.94	.50	1/4-28	.26	1.20	.16			
CT-11	1 1/16 (6)	.50	.26	.94	.50	5/16-24	.26	1.20	.19		
CT-15	1 1/4 (25) & 1 1/2 (5)	.75	.38	1.30	.75	7/16-20	.38	1.70	.25		
CT-19	1 3/4 (75), 2(4), 2 1/2 (3)	.75	.38	1.30	.75	1/2-20	.38	1.70	.31		

### FOOT MOUNT

- For nose mounting and double-end mounting
- Gusseted for added strength

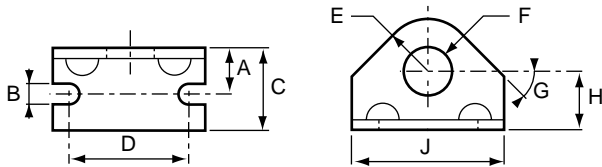

F-8-S	1/2 (8) Single Acting Types*	.31	.19	.62	1.00	.37	.38	56°	.57	1.38	
F-8	1/2 (8) Double Acting Types	.31	.19	.62	1.00	.37	.44	56°	.57	1.38	
F-7	3/4 (7) Single Acting Types**	.44	.19	.75	1.25	.40	.50	45°	.69	1.63	
F-11 1/16 (6)	3/4 (7) Double Acting Single & 56 Double Acting Types	.27	1.00	1.50	.56	.63	45°	.81	1.88		
F-15 1 1/4 (25) & 1 1/2 (5) All Types		.77	.27	1.50	1.89	.76	.76	49°	1.00	2.50	
F-75 1 3/4 (75) All Types		.94	.34	1.50	2.25	.88	1.04	52°	1.25	3.00	
F-192 (4) All Types 1.00		.34	1.62	2.25	1.00	1.38	60°	1.50	3.12		
F-212 1/2 (3) All Types 1.00		.34	1.62	2.88	1.25	1.50	63°	1.75	3.75		

\*Model 8-SP requires one each F-8-S and F-8 for double end mount.

\*\*Models 7-SP and 7-SHP require one each F-7 and F-11 for double end mount.

### MOUNTING NUT/JAM NUT

- Mounting Nut for nose or pivot tang threads
- Jam Nut for locking Rod Clevis

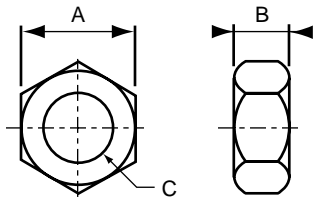

Mounting Nut No.	Where to Use Cyl. Bore & Type	A	B	C	Clevis Nut No.	Where to Use Cyl. Bore Size All Types Com.	A	B	C
JN-8-S	1/2 Single Acting*	.56	.22	3/8-24	C110-9	1/2	.370	.12	10-32
JN-8	1/2 Double Acting	.68	.25	7/16-20	C110-762	3/4	.43	.16	1/4-28
JN-7	3/4 Single Acting**	.75	.31	1/2-20	C110-763	1 1/16	.50	.19	5/16-24
JN-11	3/4 Double Acting 1 1/16 All Types	.93	.37	5/8-18	JN-8	1 1/4 & 1 1/2	.68	.25	7/16-20
JN-15	1 1/4 All Types 1 1/2 All Types	1.12	.42	3/4-16	JN-7	1 3/4 & 2 & 2 1/2	.75	.31	1/2-20
JN-75	1 3/4 All Types	1.50	.56	1-14					
JN-19	2 All Types	1.88	.50	1 1/4-12					
JN-21	2 1/2 All Types	2.06	.50	1 3/8-12					

\*Model 8-SP requires one each JN-8-S and JN-8 for double end mount.

\*\*Models 7-SP and 7-SHP require one each JN-7 and JN-11 for double end mount.

ACCESSORIES

HUMPHREY AIR CYLINDERS

**PIVOT PINS**

May be ordered separately

\*\*NOTE: Changed to Cotter Pin in November 1990.

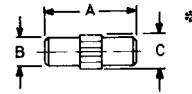
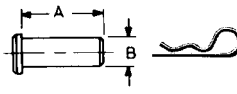
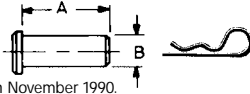

Bore Size	As supplied with Pivot Bracket:					As supplied with Rod Clevis:					For press-fit into pivot hole			
	Pivot Pin	Retainer	A	B	Prefix BP-	Clevis Pin	Retainer	A	B	Prefix CT-	Pivot Pin	A	B	C
1/2 (8)	7563	7571	.70	.15	-8C	7568	7571	.55	.18	-8	C32-413	.50	.15	.17
3/4 (7) & 1 1/16 (6)	7564	757	.85	.25	-11C	7569	7571	.67	.25	-7	C32-619	.75	.24	.26
1 1/4 (25)	7565	7571	.98	.25	-25C	7569	7572	.94	.37	-11	C32-412	.87	.24	.26
1 1/2 (5) & 1 3/4 (75)	7566	7572	1.19	.37	-15C	7570	7572	.94	.37	-15	C32-928	1.12	.37	.39
2 (4) 2 1/2 (3)*	7567	7572	1.43	.37	-19C	7570	7572	.94	.37	-19				

\*2 & 2 1/2 Bore models used shoulder bolt (Model C110-768), and nut (Model C110-759).

# HUMPHREY VOLUME CHAMBERS

- For Vacuum or Air
- Ideal for Time Delay circuits
- Stainless Steel barrel
- Aluminum end caps

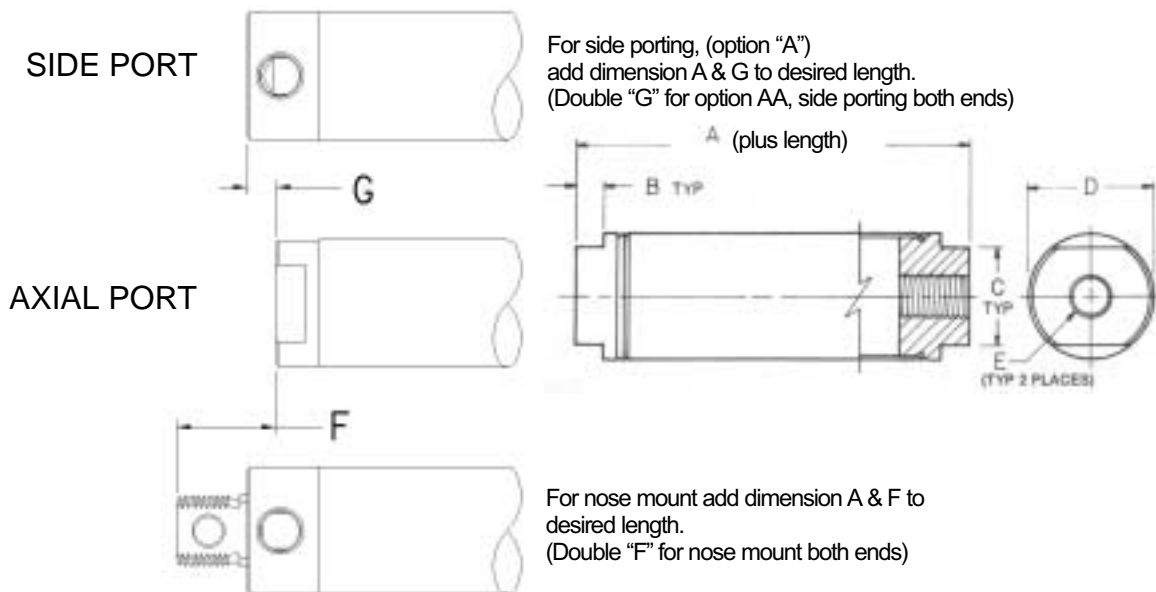

## Order Example

Model    Type    Length    Options

8            C            5            A or AA

A = Side Port (one end)  
AA = Side Port (both ends)

C = Axial piping (both ends) <sup>Note 1</sup>  
CP = Nose mount (one end) <sup>Note 2</sup>  
CPP = Nose mount (both ends)

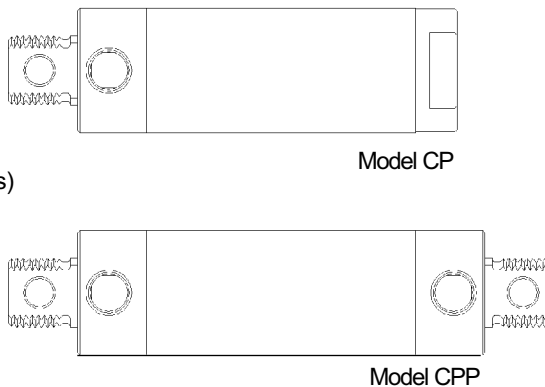

Note 1: Add Option A for side porting one end, Option AA for both ends.  
Note 2: CP also available with Option A.

MODEL	BORE Dia. In.	VOLUME IN CU.		DIMENSIONS						
		Basic Volume*	Add per 1.0 inch length	A	B	C	D	E NPSF	F	G
8-C- <input type="checkbox"/>	1/2	.11	.20	1.35	.11	.37	.56	10-32	.96	.19
7-C- <input type="checkbox"/>	3/4	.40	.44	1.91	.16	.62	.81	1/8	1.35	.44
6-C- <input type="checkbox"/>	1 1/16	.88	.89	2.18	.25	.88	1.11	1/8	.88	.25
25-C- <input type="checkbox"/>	1 1/4	1.44	1.23	2.67	.18	.87	1.30	1/8	1.08	.31
5-C- <input type="checkbox"/>	1 1/2	1.68	1.77	2.26	.25	.88	1.55	1/8	1.06	.19
75-C- <input type="checkbox"/>	1 3/4	3.29	2.41	2.57	.25	1.24	1.80	1/4	1.56	.56
4-C- <input type="checkbox"/>	2	4.04	3.14	2.81	.32	1.25	2.07	1/4	1.37	.37
3-C- <input type="checkbox"/>	2 1/2	6.38	4.91	2.81	.31	2.07	2.61	1/4	1.37	.37

▲ YOU ENTER LENGTH HERE IN 1-INCH INCREMENTS.

\*Add this volume to sum of the Per Inch Volume.  
This basic volume exists before any 1-inch increments are added.  
ORDER EXAMPLE: 5-C-2 (1 1/2 inch Bore/C type/2 inch length.  
5.80 IN. CU. volume 4.26 inches total length

# Air DX Deluxe Rod™ Cylinders Program

Welcome to the newest, most innovative special cylinder ordering program ever developed by a U.S. manufacturer of pneumatic cylinders...

## The Humphrey DX Deluxe Rod Cylinders Program

Humphrey DX Deluxe Rod™ Cylinders turn cylinders previously categorized as "specials" into standard, make-to-order products. The Deluxe Rod ordering system provides a fast, easy, cost effective way to produce cylinders for customers who have requirements for non-cataloged rod features and/or dimensions.

In effect, the DX concept enables a customer to design, specify, and order a unique cylinder on the spot, quickly and efficiently, with no long lead times, and no minimum order quantities.

Once the customer has decided upon the particular rod requirements, that information is filled-in on the order sheet for the specific DX option desired. The order sheet is faxed or mailed to Humphrey, and upon receipt, is entered into the processing stream immediately and is queued for fabrication and assembly. No specials. No long lead times. No minimum order quantities. Just "what you need when you need it."

### Benefits of the DX Rod concept

- Variety. Currently, fifteen different rod types are offered, each with its own specific set of user definable dimensions. The user creates a cylinder that is essentially unique. There are literally millions of different combinations.
- Normal delivery time. These products are manufactured in our regular production stream. They are not classified as "specials," but are standard products. Consequently, delivery time on most orders is our normal delivery time.
- No minimum quantities. Most "specials" are subject to a minimum order quantity. Because these products are not classified as "specials," they can be ordered in any quantity, from one to infinity. The customer is no longer faced with minimum order quantities and unneeded purchases.
- Humphrey Quality. Our HMQ and TOE processes help provide the excellent quality that customers have come to expect from Humphrey. At Humphrey, quality is an ongoing process that never stops.

### How to Use This Information

Please refer to "DX Options at a Glance" (following the Restrictions and Limitations section). This provides a quick overview of the various rods that are readily available. This page 5 can also be used as a design tool to give customers numerous ideas to help create ideal design solutions.

The DX Options at a Glance sheet is followed by the actual order sheets themselves. Photocopy the order sheet, complete the requested information, and fax or mail the form to Humphrey.

Please examine any one of the order sheets that follow the Options at a Glance page 18. Note that a DX number appears in the upper right corner of each sheet. This number identifies the particular option described on the sheet. Also at the top of the sheet is information the customer has to complete regarding cylinder model and stroke, expected ship date, and other details. A large drawing of the rod shows the dimensions pertinent to the particular option. The dimensions that are

"Size" Box

LETTER	SIZE	Ref.
D		1.
J		2.
JL		3.
S	.047 or .094	4.

This is the number of the limitations to check against in the references below each drawing.

# Air DX Deluxe Rod™ Cylinders Program

Below the drawing is information to be completed by Humphrey. This is followed by an explanation of the intended purpose of the particular DX option. This, in turn, is followed by a Reference section that lists certain restrictions on certain customer-selected dimensions. The restrictions are imposed to keep manufacturing flowing smoothly.

## How to fill out the Order Sheets

Once a DX option has been selected, the original order sheet should be photocopied so that the original can be used again. The information can either be typed or printed clearly by hand. Complete the boxed information as follows:

Distributor's Purchase Order Number: \_\_\_\_\_

Distributor Name: This is the name of the distributor that is ordering the cylinder(s). \_\_\_\_\_

Customer Name: This is the customer that requested the cylinder(s). \_\_\_\_\_

Ship to Address: This is the address to where Humphrey will ship the completed cylinder(s). \_\_\_\_\_

Contact Person: This is the distributor contact person. \_\_\_\_\_

Contact Person: This is the customer contact person. \_\_\_\_\_

<b>Distributor Name:</b>		<b>Contact Person:</b>		<b>PO#</b>		<b>DX01</b>
<b>Customer Name:</b>		<b>Contact Person:</b>		<b>PO#</b>		
<b>Ship To Address:</b>		<b>Requested Ship Date:</b>				
		<b>Model, Type, Stroke, and Options:</b>		<b>Qty:</b>		

Requested Ship Date: This is the date that the customer would like to see the order leave Humphrey Products. A 7 day minimum lead time is required \_\_\_\_\_

Qty: The quantity of this particular model cylinder desired. \_\_\_\_\_

Model Type Stroke and Options: Enter here the cylinder Model (ex. 3, 4, 25 etc.), the Type (ex. D, DP, SRP, etc.), the Stroke desired for the cylinder (in 1/16 inch increments) and any Options desired (ex. B = Bumper, M = Magnet, etc.). \_\_\_\_\_

# Air DX Deluxe Rod™ Cylinders Program

Next, complete the information in the "Size" box at the right of the drawing, taking care to check this against the References at the bottom portion of the sheet. Simply write-in "STD" for any standard catalog dimension desired. For example, if a customer wants a DX05 option, and wants to change the "D" dimension only, the other boxes should be marked "STD". The cylinder supplied would have the customer-specified "D" dimension and standard threads. Refer to Table 5 for a definition of all Standard Dimensions. A completed example order sheet follows.

Distributor Name:	ACME FLUID POWER	Contact Person:	AMANDA B. RECONDWITH	PO#	P040625	<b>DX05</b>
Customer Name:	JOHNSON AUTOMATION	Contact Person:	ANITA D. LUCKS	PO#	\$5R4056	
Ship To Address:	10027 8th STREET BEMIDJI, MN 48685	Requested Ship Date:	FEBRUARY 23, 1996			
		Model, Type, Stroke, and Options:	6-DP 4 $\frac{3}{4}$ B	Qty:	3	

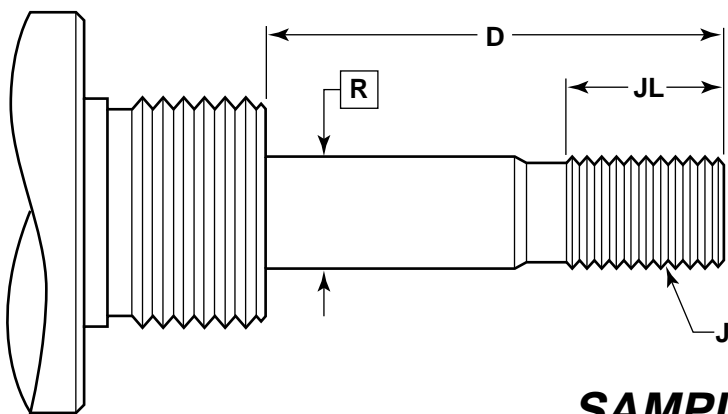

LETTER	SIZE	Ref.
D	STD	1.
J	$\frac{1}{4}$ - 20 UNC	2.
JL	STD	3.

## SAMPLE ORDER

(Everything is standard except the thread type)

**Below for Humphrey use only:**

Entered By:	Date:	Order Number:	Tracking #:	Delivery Date:	Price:
-------------	-------	---------------	-------------	----------------	--------

# Air DX Deluxe Rod™ Cylinders Program

## Program Restrictions and Limitations

Because of the high degree of flexibility of the DX Deluxe Rod concept, some exceptions are necessary:

- One DX option per cylinder order. This means that only one DX option may appear on a cylinder rod at a time.
- This program is available on cylinders with round rods only: it is available only on those Humphrey Stainless Steel Barrel Cylinder that have model prefixes from #8 (1/2 inch bore) to #3 (2-1/2 inch bore). Hex-rod cylinders do not qualify for this program. This program is also not available on double-end rod (D2EY) cylinders.
- Once the order is received at Humphrey, it is considered firm and non-cancelable.
- Only the threads, cross-holes, and dimensions shown in Tables 1 through 4 are available
- Dimensions in Table 4 are determined by the cylinder itself and cannot be modified.
- Humphrey Products reserves the right to either roll or cut the threads available on DX models.
- All threads will be Class 2 for US threads, and Class 6-H for metric threads.
- The restrictions and limitations listed below each DX option prevent cut metal from entering the cylinder head. Internal female rod threads, however, may enter the cylinder head.
- Products outside the parameters of the DX Rod capabilities must be considered "special."

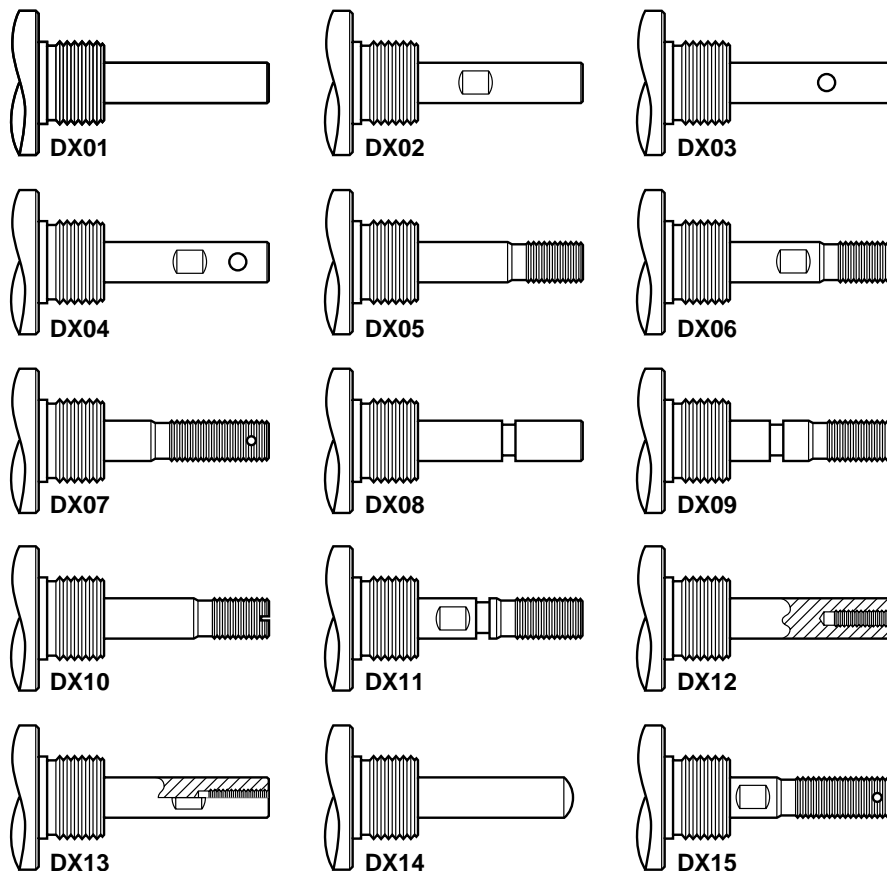

# Air DX Deluxe Rod™ Cylinders Program

<b>Distributor Name:</b>	<b>Contact Person:</b>	<b>PO#</b>	<b>DX15</b>
<b>Customer Name:</b>	<b>Contact Person:</b>	<b>PO#</b>	
<b>Ship To Address:</b>	<b>Requested Ship Date:</b>		
	<b>Model, Type, Stroke, and Options:</b>		<b>Qty:</b>

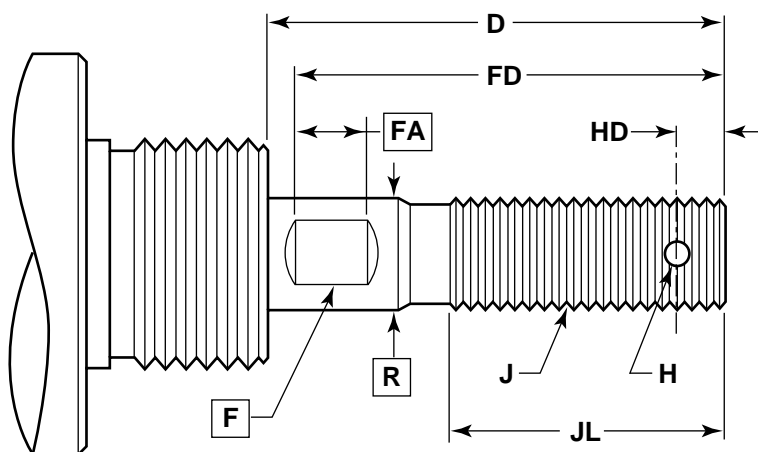

LETTER	SIZE	Ref.
D		1.
HD		2.
H		3.
FD		4.
J		5.
JL		6.

**Below for Humphrey use only:**

<b>Entered By:</b>	<b>Date:</b>	<b>Order Number:</b>	<b>Tracking #:</b>	<b>Delivery Date:</b>	<b>Price:</b>
--------------------	--------------	----------------------	--------------------	-----------------------	---------------

DX15: Not available on model 8. Metric allowed for "J" size. All other dimensions are to be in inches.

Purpose: Allows user to specify a thread definition, plus a cotter pin cross hole, and locate a wrench flat on a rod of variable length. The cross hole is intended for use with a cotter pin and not a dowel pin. See Table 4 for boxed dimension definitions.

1.  $D \geq 0$  and  $D < 6.0$   
(Rod extension must be greater than or equal to 0.00" and less than or equal to 6.00")
2.  $HD > (1/2 \times H) + .030$  (minimum wall thickness around hole) and  $HD \leq D - (1/2 \times H)$  and  
If U.S. Thread Then  
HD must be less than or equal to  $JL + (2 \div "J" \text{ Pitch}) - (1/2 \times H)$  or  
HD must be greater than  $JL + (2 \div "J" \text{ Pitch}) + (1/2 \times H) + .030$  (minimum wall thickness around hole)  
Else (Metric Threads)  
HD must be less than or equal to  $JL + (2 \times "J" \text{ Pitch converted to inches}) - (1/2 \times H)$  or  
HD must be greater than  $JL + (2 \times "J" \text{ Pitch converted to inches}) + (1/2 \times H) + .030$  (minimum wall thickness around hole)  
(This constraint ensures that the cross-drilled hole will not break out of the end of the rod or enter nose and/or bearing and that the hole does not appear on the step-down angle for the threaded area.)
3.  $H = .078$  or  $.141$  depending on the model and thread size. See Table 3 for hole sizes based on models.  
If  $HD < JL + (1/2 \times H) + [(2 \div "J" \text{ Pitch})]$  if U.S. Threads,  $(2 \times "J" \text{ Pitch converted to inches})$  if Metric threads] Then H must be less than equal to  $.4 \times "J" \text{ Size}$   
(A smaller than standard thread size may prohibit inclusion of the largest available hole.)

4.  $FD \leq D$  and  $FD > FA$  and  
[  $FD \geq FA + .075 \text{ flat Radius} + (1/2 \times H) + HD$  or  $FD \leq HD - (1/2 \times H) - .075 \text{ (Flat Radius)}$  or  $FD \geq HD + (1/2 \times H)$  and  $FD \leq HD - (1/2 \times H) + FA$ ] and  
If  $F > "J" \text{ Size}$  Then  
If U.S. Threads Then  
FD must be greater than equal to  $(FA \div 2) + JL + (2 \div "J" \text{ Pitch})$   
Else  
FD must be greater than equal to  $(FA \div 2) + JL + (2 \times "J" \text{ Pitch converted to inches})$   
(These constraints ensure the following:  
A. The wrench flat cannot enter the nose and/or the bearing.  
B. The rod will contain the entire wrench flat.  
C. When the thread size is smaller than the wrench flat width, at least one half of the wrench flat must be located on the rod diameter.  
D. The cross-hole does not fall on the rounds of the wrench flat.)
5. J: There are two parts: Size and Threads Per Inch. Choose the thread desired from Table 1. Place the desired description for the thread size desired in this box. Maximum thread size for your model can be determined by referring to Table 1.
6. JL: Length of the threads  
 $JL \leq 6 \times "J" \text{ Size (decimal format)}$  and  
If U.S. thread:  $JL \leq D - (2.0 \div "J" \text{ Pitch})$   
If Metric thread:  $JL \leq D - (2.0 \times "J" \text{ Pitch converted to inches})$   
Minimum U.S. External Thread Length =  $3 \div "J" \text{ pitch (Threads Per Inch)}$   
Minimum Metric External Thread Length =  $3 \times "J" \text{ pitch converted to inches}$   
Example: Desired thread is 5/16-18  
 $JL > 3 \div 18$  and  
 $JL \leq 6.0 \times 5/16$  and  
 $JL \leq D - (2.0 \div 18.0)$   
(These constraints ensure the following:  
A. Proper pitch can be maintained over the full length of thread.

B. Thread length will not enter the nose/bearing of front head.  
C. Thread length will leave room for proper turn diameter including chamfer.)

# Air DX Deluxe Rod™ Cylinders Program

**Table 1**  
**External Threads**  
(Thread sizes available on DX options)

	<b>English</b> (Class 2 Fit)	<b>Metric</b> (H6 Fit)					
Model 4 & 3	Model 75	Model 25 & 5	Model 6	Model 7	Model 8	#8-32 UNC	M3 x .50
						#8-36 UNF	M4 x .7
						#10-24 UNC	M5 x .80
						#10-32 UNF	M6 x 1.00
						1/4-20 UNC	M8 x 1.25
						1/4-28 UNF	M8 x 1.00
						5/16-18 UNC	M10 x 1.50
						5/16-24 UNF	M10 x 1.25
						3/8-16 UNC	M12 x 1.75
						3/8-24 UNF	M12 x 1.50
						7/16-14 UNC	M14 x 2.00
						7/16-20 UNF	M14 x 1.50
						1/2-13 UNC	M15 x 1.00
						1/2-20 UNF	M16 x 2.00
Model 4 & 3	Model 75	Model 25 & 5	Model 6	Model 7	Model 8	9/16-12 UNC	M16 x 1.50
						9/16-18 UNF	
						5/8-11 UNC	
						5/8-18 UNF	

**Table 2**  
**Internal Threads**  
(Internal threads available for the DX options)  
(Internal Metric Threads not Available)  
(Not Available on Models 8 & 7)

<b>English</b> (Class 2 Fit)
#8-32 UNC
#8-36 UNF
#10-24 UNC maximum internal threads
#10-32 UNF Model 6
1/4-20 UNC
1/4-28 UNF Model 5, 25, & 75
5/16-18 UNC
5/16-24 UNF
3/8-16 UNC
3/8-24 UNF Model 3 & 4

**Table 3**  
**Cross-hole Sizes**  
(The size of cross-hole available depends on the model)

	.078"	.141"
Model 3	•	•
Model 4	•	•
Model 75	•	•
Model 5	•	•
Model 25	•	•
Model 6	•	NA
Model 7	•	NA
Model 8	•	NA

• - Hole available  
If hole falls on threaded portion of rod the hole size must be at most 40% of basic thread size.

NA - Hole not available for this model

.078" hole for 1/16" cotter pin  
.141" hole for 1/8" cotter pin

# Air DX Deluxe Rod™ Cylinders Program

**Table 4  
Boxed Dimensions**

(Definitions of the boxed dimensions on the order sheets)  
(Boxed dimensions are determined by cylinder model and are not modifiable under this program.)

- B** - Corner Break Size
- F** - Width Across Flats (Wrench size)
- FA** - Flat Length
- R** - Rod Diameter
- S** - Screwdriver Slot Size (SEE DX10 for slot sizes)
- 3/2 (s)** - Depth of Screwdriver Slot

	<b>B</b>	<b>F</b>	<b>FA</b>	<b>R</b>
Model 3	.015	.500	.278	.625
Model 4	.015	.500	.278	.625
Model 75	.015	.438	.278	.500
Model 5	.015	.375	.275	.437
Model 25	.015	.375	.275	.437
Model 6	.015	.250	.188	.312
Model 7	.015	.219	.188	.250
Model 8	.015	NA	NA	.187

**Table 5  
Standard ("Std") Dimensions**

**Round Heads**

	<b>D</b>	<b>FD</b>	<b>J</b>	<b>JL</b>
Model 8	.50	NA	10-32	.50
Model 7	.50	NA	1/4-28	.50
Model 6	.62	.60	5/16-24	.50
Model 25	1.00	.93	7/16-20	.75
Model 5	1.00	.93	7/16-20	.75
Model 75	1.19	1.14	1/2-20	.88
Model 4	1.25	1.15	1/2-20	.88
Model 3	1.25	1.15	1/2-20	.88

**Block Mount Heads**

	<b>D</b>	<b>FD</b>	<b>J</b>	<b>JL</b>
Model 8	.50	NA	10-32	.50
Model 7	1.06	1.01	1/4-28	.75
Model 6	1.12	1.01	5/16-24	.75
Model 25	NA	NA	NA	NA
Model 5	1.50	1.43	7/16-20	1.25
Model 75	NA	NA	NA	NA
Model 4	NA	NA	NA	NA
Model 3	NA	NA	NA	NA

# Air DX Deluxe Rod™ Cylinders Program

Distributor Name:	Contact Person:	PO#	<b>DX14</b>
Customer Name:	Contact Person:	PO#	
Ship To Address:	Requested Ship Date:		
	Model, Type, Stroke, and Options:	Qty:	

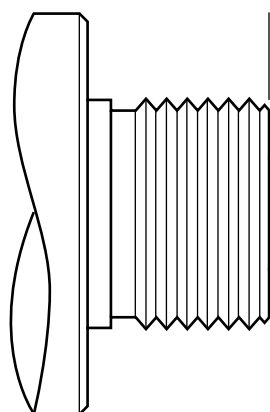

LETTER	SIZE	Ref.
D		1.
RAD		2.

See note below \*

### Below for Humphrey use only:

Entered By:	Date:	Order Number:	Tracking #:	Delivery Date:	Price:
-------------	-------	---------------	-------------	----------------	--------

DX14: Available on all cylinder models (prefix #8 through prefix #3). All dimensions are to be in inches.

Purpose: Allows user to specify a spherical radius run out on the end of a variable length rod end. See Table 4 for boxed dimension definitions.

\* Note: .030 Diameter (maximum) flat may occur at the end of the rod due to manufacturing processes.

#### References:

1.  $D \geq 0$  and  
 $D \leq 6.0$

(Rod extension must be greater than or equal to 0.00" and less than or equal to 6.00")

2.  $RAD \geq 1/2 R$  and  
 $RAD \leq 10.0$

(The maximum radius of 10.00 has very little radius at all on the rod end. The minimum radius (1/2 of the rod diameter) provides the greatest rounding on the rod end.)

# Air DX Deluxe Rod™ Cylinders Program

**Table 1**  
**External Threads**  
(Thread sizes available on DX options)

	<b>English</b> (Class 2 Fit)	<b>Metric</b> (H6 Fit)		
Model 4 & 3	Model 75 Model 25 & 5 Model 6 Model 7 Model 8	Model 75 Model 25 & 5 Model 6 Model 7 Model 8	#8-32 UNC	M3 x .50
			#8-36 UNF	M4 x .7
			#10-24 UNC	M5 x .80
			#10-32 UNF	M6 x 1.00
			1/4-20 UNC	M8 x 1.25
			1/4-28 UNF	M8 x 1.00
			5/16-18 UNC	M10 x 1.50
			5/16-24 UNF	M10 x 1.25
			3/8-16 UNC	M12 x 1.75
			3/8-24 UNF	M12 x 1.50
			7/16-14 UNC	M14 x 2.00
			7/16-20 UNF	M14 x 1.50
			1/2-13 UNC	M15 x 1.00
			1/2-20 UNF	M16 x 2.00
			9/16-12 UNC	M16 x 1.50
			9/16-18 UNF	
			5/8-11 UNC	
5/8-18 UNF				

**Table 2**  
**Internal Threads**  
(Internal threads available for the DX options)  
(Internal Metric Threads not Available)  
(Not Available on Models 8 & 7)

<b>English</b> (Class 2 Fit)
#8-32 UNC
#8-36 UNF
#10-24 UNC maximum internal threads
#10-32 UNF Model 6
1/4-20 UNC
1/4-28 UNF Model 5, 25, & 75
5/16-18 UNC
5/16-24 UNF
3/8-16 UNC
3/8-24 UNF Model 3 & 4

**Table 3**  
**Cross-hole Sizes**  
(The size of cross-hole available depends on the model)

	.078"	.141"
Model 3	•	•
Model 4	•	•
Model 75	•	•
Model 5	•	•
Model 25	•	•
Model 6	•	NA
Model 7	•	NA
Model 8	•	NA

• - Hole available  
If hole falls on threaded portion of rod the hole size must be at most 40% of basic thread size.

NA - Hole not available for this model

.078" hole for 1/16" cotter pin  
.141" hole for 1/8" cotter pin

# Air DX Deluxe Rod™ Cylinders Program

**Table 4  
Boxed Dimensions**

(Definitions of the boxed dimensions on the order sheets)  
(Boxed dimensions are determined by cylinder model and are not modifiable under this program.)

- B** - Corner Break Size
- F** - Width Across Flats (Wrench size)
- FA** - Flat Length
- R** - Rod Diameter
- S** - Screwdriver Slot Size (SEE DX10 for slot sizes)
- 3/2 (s)** - Depth of Screwdriver Slot

	<b>B</b>	<b>F</b>	<b>FA</b>	<b>R</b>
Model 3	.015	.500	.278	.625
Model 4	.015	.500	.278	.625
Model 75	.015	.438	.278	.500
Model 5	.015	.375	.275	.437
Model 25	.015	.375	.275	.437
Model 6	.015	.250	.188	.312
Model 7	.015	.219	.188	.250
Model 8	.015	NA	NA	.187

**Table 5  
Standard ("Std") Dimensions**

**Round Heads**

	<b>D</b>	<b>FD</b>	<b>J</b>	<b>JL</b>
Model 8	.50	NA	10-32	.50
Model 7	.50	NA	1/4-28	.50
Model 6	.62	.60	5/16-24	.50
Model 25	1.00	.93	7/16-20	.75
Model 5	1.00	.93	7/16-20	.75
Model 75	1.19	1.14	1/2-20	.88
Model 4	1.25	1.15	1/2-20	.88
Model 3	1.25	1.15	1/2-20	.88

**Block Mount Heads**

	<b>D</b>	<b>FD</b>	<b>J</b>	<b>JL</b>
Model 8	.50	NA	10-32	.50
Model 7	1.06	1.01	1/4-28	.75
Model 6	1.12	1.01	5/16-24	.75
Model 25	NA	NA	NA	NA
Model 5	1.50	1.43	7/16-20	1.25
Model 75	NA	NA	NA	NA
Model 4	NA	NA	NA	NA
Model 3	NA	NA	NA	NA

# Air DX Deluxe Rod™ Cylinders Program

Distributor Name:		Contact Person:		PO#		<b>DX13</b>
Customer Name:		Contact Person:		PO#		
Ship To Address:		Requested Ship Date:				
		Model, Type, Stroke, and Options:		Qty:		

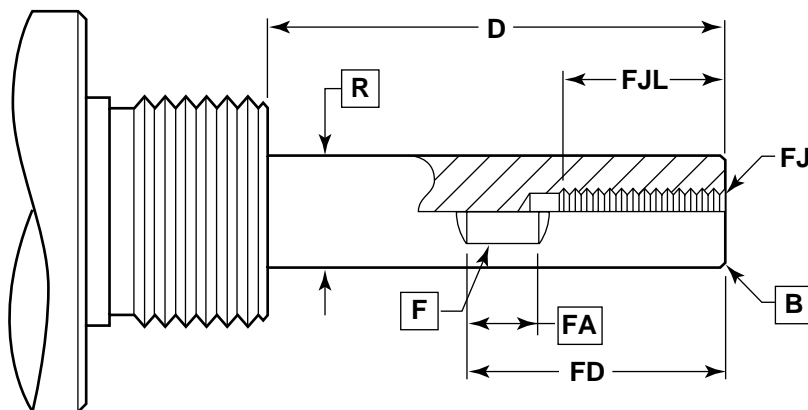

LETTER	SIZE	Ref.
D		1.
FJ		2.
FJL		3.
FD		4.

**Below for Humphrey use only:**

Entered By:	Date:	Order Number:	Tracking #:	Delivery Date:	Price:
-------------	-------	---------------	-------------	----------------	--------

DX13: Not available on models 7 and 8. All dimensions are to be in inches.

Purpose: Allows user to specify the location of a wrench flat plus a threaded hole in the end of a rod of variable length. See Table 4 for boxed dimension definitions.

**References**

1.  $D \geq 0$  and  $D \leq 6.0$   
(Rod extension must be greater than or equal to 0.00" and less than or equal to 6.00")
2. FJ: Contains two parts the diameter of the thread and the pitch (number of threads per inch). Choose the thread desired from Table 2. Place the description for the thread size desired in this box. Maximum thread size for your model can be determined by referring to Table 2.

3. FJL: Length of the threads  
 $FJL \leq 3.0 \times FJ \text{ Size (thread diameter)}$   
 $FJL \geq 3.0 \div FJ \text{ Pitch (threads per inch)}$   
 Example: Desired thread is 5/16-18  
 $FJL \leq 3.0 \times 5/16$  and  
 $FJL \geq 3.0 \div 18$   
 (In this example, maximum thread depth is .9375". Minimum thread depth is .1666". These are present manufacturing capabilities.)

4.  $FD \geq FA$  and  $FD \leq D$   
 (These constraints ensure the following:  
 A. The wrench flat cannot enter the nose and/or the bearing.  
 B. The rod will include the entire wrench flat.

# Air DX Deluxe Rod™ Cylinders Program

**Table 1**  
**External Threads**  
(Thread sizes available on DX options)

	<b>English</b> (Class 2 Fit)	<b>Metric</b> (H6 Fit)					
Model 4 & 3	Model 75	Model 25 & 5	Model 6	Model 7	Model 8	#8-32 UNC	M3 x .50
						#8-36 UNF	M4 x .7
						#10-24 UNC	M5 x .80
						#10-32 UNF	M6 x 1.00
						1/4-20 UNC	M8 x 1.25
						1/4-28 UNF	M8 x 1.00
						5/16-18 UNC	M10 x 1.50
						5/16-24 UNF	M10 x 1.25
						3/8-16 UNC	M12 x 1.75
						3/8-24 UNF	M12 x 1.50
						7/16-14 UNC	M14 x 2.00
						7/16-20 UNF	M14 x 1.50
						1/2-13 UNC	M15 x 1.00
						1/2-20 UNF	M16 x 2.00
Model 4 & 3	Model 75	Model 25 & 5	Model 6	Model 7	Model 8	9/16-12 UNC	M16 x 1.50
						9/16-18 UNF	
						5/8-11 UNC	
						5/8-18 UNF	

**Table 2**  
**Internal Threads**  
(Internal threads available for the DX options)  
(Internal Metric Threads not Available)  
(Not Available on Models 8 & 7)

<b>English</b> (Class 2 Fit)
#8-32 UNC
#8-36 UNF
#10-24 UNC maximum internal threads
#10-32 UNF Model 6
1/4-20 UNC
1/4-28 UNF Model 5, 25, & 75
5/16-18 UNC
5/16-24 UNF
3/8-16 UNC
3/8-24 UNF Model 3 & 4

**Table 3**  
**Cross-hole Sizes**  
(The size of cross-hole available depends on the model)

	.078"	.141"
Model 3	•	•
Model 4	•	•
Model 75	•	•
Model 5	•	•
Model 25	•	•
Model 6	•	NA
Model 7	•	NA
Model 8	•	NA

• - Hole available  
If hole falls on threaded portion of rod the hole size must be at most 40% of basic thread size.

NA - Hole not available for this model

.078" hole for 1/16" cotter pin  
.141" hole for 1/8" cotter pin

# Air DX Deluxe Rod™ Cylinders Program

**Table 4  
Boxed Dimensions**

(Definitions of the boxed dimensions on the order sheets)  
(Boxed dimensions are determined by cylinder model and are not modifiable under this program.)

- B** - Corner Break Size
- F** - Width Across Flats (Wrench size)
- FA** - Flat Length
- R** - Rod Diameter
- S** - Screwdriver Slot Size (SEE DX10 for slot sizes)
- 3/2 (s)** - Depth of Screwdriver Slot

	<b>B</b>	<b>F</b>	<b>FA</b>	<b>R</b>
Model 3	.015	.500	.278	.625
Model 4	.015	.500	.278	.625
Model 75	.015	.438	.278	.500
Model 5	.015	.375	.275	.437
Model 25	.015	.375	.275	.437
Model 6	.015	.250	.188	.312
Model 7	.015	.219	.188	.250
Model 8	.015	NA	NA	.187

**Table 5  
Standard ("Std") Dimensions**

**Round Heads**

	<b>D</b>	<b>FD</b>	<b>J</b>	<b>JL</b>
Model 8	.50	NA	10-32	.50
Model 7	.50	NA	1/4-28	.50
Model 6	.62	.60	5/16-24	.50
Model 25	1.00	.93	7/16-20	.75
Model 5	1.00	.93	7/16-20	.75
Model 75	1.19	1.14	1/2-20	.88
Model 4	1.25	1.15	1/2-20	.88
Model 3	1.25	1.15	1/2-20	.88

**Block Mount Heads**

	<b>D</b>	<b>FD</b>	<b>J</b>	<b>JL</b>
Model 8	.50	NA	10-32	.50
Model 7	1.06	1.01	1/4-28	.75
Model 6	1.12	1.01	5/16-24	.75
Model 25	NA	NA	NA	NA
Model 5	1.50	1.43	7/16-20	1.25
Model 75	NA	NA	NA	NA
Model 4	NA	NA	NA	NA
Model 3	NA	NA	NA	NA

# Air DX Deluxe Rod™ Cylinders Program

Distributor Name:	Contact Person:	PO#	<b>DX12</b>
Customer Name:	Contact Person:	PO#	
Ship To Address:	Requested Ship Date:		
	Model, Type, Stroke, and Options:	Qty:	

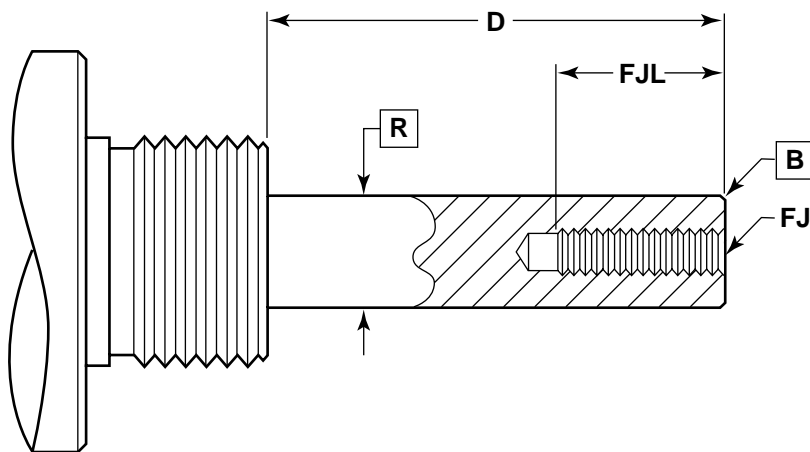

LETTER	SIZE	Ref.
D		1.
FJ		2.
FJL		3.

**Below for Humphrey use only:**

Entered By:	Date:	Order Number:	Tracking #:	Delivery Date:	Price:
-------------	-------	---------------	-------------	----------------	--------

DX12: Not available on models 7 and 8. All dimensions are to be in inches.

Purpose: Allows user to specify a threaded hole in the end of a rod of varying length. See Table 1 for boxed dimension definitions.

References

1.  $D \geq 0$  and  $D \leq 6.0$   
(Rod extension must be greater than or equal to 0.00" and less than or equal to 6.00")
2. FJ: Contains two parts the diameter of the thread and the pitch (number of threads per inch). Choose the thread desired from Table 2. Place the description for the thread size in this box. Maximum thread size for your model can be determined by referring to Table 2.

3. FJL: Length of the threads  
 $FJL \leq 3.0 \times FJ \text{ Size (thread diameter)}$   
 $FJL \geq 3.0 \div FJ \text{ Pitch (threads per inch)}$   
 Example: Desired thread is 5/16-18  
 $FJL \leq 3.0 \times 5/16$  and  
 $FJL \geq 3.0 \div 18.0$   
 (In this example, maximum thread depth is .9375" . Minimum thread depth is .1666" . These are present manufacturing capabilities.)

# Air DX Deluxe Rod™ Cylinders Program

**Table 1**  
**External Threads**  
(Thread sizes available on DX options)

	<b>English</b> (Class 2 Fit)	<b>Metric</b> (H6 Fit)					
Model 4 & 3	Model 75	Model 25 & 5	Model 6	Model 7	Model 8	#8-32 UNC	M3 x .50
						#8-36 UNF	M4 x .7
						#10-24 UNC	M5 x .80
						#10-32 UNF	M6 x 1.00
						1/4-20 UNC	M8 x 1.25
						1/4-28 UNF	M8 x 1.00
						5/16-18 UNC	M10 x 1.50
						5/16-24 UNF	M10 x 1.25
						3/8-16 UNC	M12 x 1.75
						3/8-24 UNF	M12 x 1.50
Model 4 & 3	Model 75	Model 25 & 5	Model 6	Model 7	Model 8	7/16-14 UNC	M14 x 2.00
						7/16-20 UNF	M14 x 1.50
						1/2-13 UNC	M15 x 1.00
						1/2-20 UNF	M16 x 2.00
						9/16-12 UNC	M16 x 1.50
						9/16-18 UNF	
						5/8-11 UNC	
						5/8-18 UNF	

**Table 2**  
**Internal Threads**  
(Internal threads available for the DX options)  
(Internal Metric Threads not Available)  
(Not Available on Models 8 & 7)

<b>English</b> (Class 2 Fit)
#8-32 UNC
#8-36 UNF
#10-24 UNC maximum internal threads
#10-32 UNF Model 6
1/4-20 UNC
1/4-28 UNF Model 5, 25, & 75
5/16-18 UNC
5/16-24 UNF
3/8-16 UNC
3/8-24 UNF Model 3 & 4

**Table 3**  
**Cross-hole Sizes**  
(The size of cross-hole available depends on the model)

	.078"	.141"
Model 3	•	•
Model 4	•	•
Model 75	•	•
Model 5	•	•
Model 25	•	•
Model 6	•	NA
Model 7	•	NA
Model 8	•	NA

• - Hole available  
If hole falls on threaded portion of rod the hole size must be at most 40% of basic thread size.

NA - Hole not available for this model

.078" hole for 1/16" cotter pin  
.141" hole for 1/8" cotter pin

# Air DX Deluxe Rod™ Cylinders Program

**Table 4  
Boxed Dimensions**

(Definitions of the boxed dimensions on the order sheets)  
(Boxed dimensions are determined by cylinder model and are not modifiable under this program.)

- B** - Corner Break Size
- F** - Width Across Flats (Wrench size)
- FA** - Flat Length
- R** - Rod Diameter
- S** - Screwdriver Slot Size (SEE DX10 for slot sizes)
- 3/2 (s)** - Depth of Screwdriver Slot

	<b>B</b>	<b>F</b>	<b>FA</b>	<b>R</b>
Model 3	.015	.500	.278	.625
Model 4	.015	.500	.278	.625
Model 75	.015	.438	.278	.500
Model 5	.015	.375	.275	.437
Model 25	.015	.375	.275	.437
Model 6	.015	.250	.188	.312
Model 7	.015	.219	.188	.250
Model 8	.015	NA	NA	.187

**Table 5  
Standard ("Std") Dimensions**

**Round Heads**

	<b>D</b>	<b>FD</b>	<b>J</b>	<b>JL</b>
Model 8	.50	NA	10-32	.50
Model 7	.50	NA	1/4-28	.50
Model 6	.62	.60	5/16-24	.50
Model 25	1.00	.93	7/16-20	.75
Model 5	1.00	.93	7/16-20	.75
Model 75	1.19	1.14	1/2-20	.88
Model 4	1.25	1.15	1/2-20	.88
Model 3	1.25	1.15	1/2-20	.88

**Block Mount Heads**

	<b>D</b>	<b>FD</b>	<b>J</b>	<b>JL</b>
Model 8	.50	NA	10-32	.50
Model 7	1.06	1.01	1/4-28	.75
Model 6	1.12	1.01	5/16-24	.75
Model 25	NA	NA	NA	NA
Model 5	1.50	1.43	7/16-20	1.25
Model 75	NA	NA	NA	NA
Model 4	NA	NA	NA	NA
Model 3	NA	NA	NA	NA

# Air DX Deluxe Rod™ Cylinders Program

<b>Distributor Name:</b>		<b>Contact Person:</b>		<b>PO#</b>		<b>DX11</b>
<b>Customer Name:</b>		<b>Contact Person:</b>		<b>PO#</b>		
<b>Ship To Address:</b>	<b>Requested Ship Date:</b>					
	<b>Model, Type, Stroke, and Options:</b>					<b>Qty:</b>

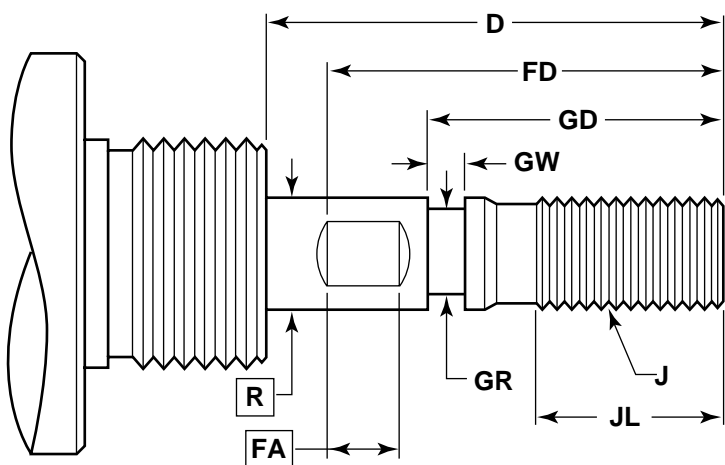

LETTER	SIZE	Ref.
D		1.
GR		2.
GD		3.
GW		4.
J		5.
JL		6.
FD		7.

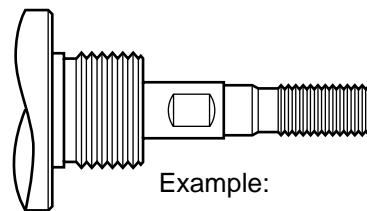

**Below for Humphrey use only:**

<b>Entered By:</b>	<b>Date:</b>	<b>Order Number:</b>	<b>Tracking #:</b>	<b>Delivery Date:</b>	<b>Price:</b>
--------------------	--------------	----------------------	--------------------	-----------------------	---------------

DX11: Not available on model 8. Metric allowed for "J". All other dimensions are to be in inches.

Purpose: Allows user to specify the location of a wrench flat, the location and width of a groove, and the definition of a desired thread all on a rod of variable length. See Table 4 for boxed dimension definitions.

**References**

1.  $D \geq 0$  and  $D \leq 6.0$   
(Rod extension must be greater than or equal to 0.00" and less than or equal to 6.00")
2.  $GR \geq .6 \times R$  and  $GR \leq R$   
(For proper strength of the rod in the groove area, 60% of the original rod diameter must remain.)
3.  $GD \leq D$  and  $(GD \geq FD + .075 \text{ (Flat Radius)} + GW$  or  $(GD \leq FD - .075 \text{ (Flat Radius)} - FA$  and if U.S.Threads Then GD must be greater than or equal to  $JL + GW + (2 \div \text{"J" Pitch})$  Else (Metric threads) GD must be greater than or equal to  $JL + GW + (2 \times \text{"J" Pitch converted to inches})$ )  
(This constraint keeps the groove from entering the thread run-out and chamfer area and eliminates the potential for the wrench flat to enter into the groove area.)
4.  $GW \geq .030$  (minimum groove width) and if "J" Size  $> GR$  Then if U.S.Threads Then GW must be less than equal to  $GD - JL - (2 \div \text{"J" Pitch})$  Else (Metric Threads) GW must be less than or equal to  $GD - JL - (2 \times \text{"1" Pitch converted to inches})$   
(Ensures that if the thread diameter is larger than the groove width diameter, the groove may not enter the threaded area.)

5. J: There are two parts: Size and Threads Per Inch. Choose the thread desired from Table 1. Place the description for the thread size in this box. Maximum thread size for a model can be determined by referring to Table 1.
6. JL: Length of the threads  
 $JL \leq 6 \times \text{"J" Size (decimal format)}$  and  
If U.S. thread:  $JL \leq D - (2.0 \div \text{"J" Pitch})$   
If Metric thread:  $JL \leq D - (2.0 \times \text{"J" Pitch converted to inches})$   
  
Minimum U.S. External Thread Length =  $3 \div \text{"J" Pitch (Threads Per Inch)}$   
Minimum Metric External Thread Length =  $3 \times \text{"J" (Pitch converted to inches)}$   
Example: Desired thread is 5/16-18  
 $JL \geq 3 \div 18$  and  
 $JL \leq 6.0 \times 5/16$  and  
 $JL \leq D - (2.0 \div 18.0)$   
(These constraints ensure the following:  
A. Proper pitch can be maintained the full Length of thread.  
B. Thread Length will not enter the nose/bearing of front head.  
C. Thread length will leave room for proper turn diameter including chamfer.)
7.  $FD \leq D$  and  $FD \geq FA$  and if  $F > \text{"J" Size}$  Then if U.S.Threads Then FD must be greater than equal to  $(FA \div 2) + JL + (2 \div \text{"J" Pitch})$  Else (Metric Threads) FD must be greater than equal to  $(FA \div 2) + JL + (2 \times \text{"J" Pitch converted to inches})$   
(These constraints ensure the following:  
A. The wrench flat cannot enter the nose and/or the bearing.  
B. The rod will contain the entire wrench flat.  
C. When the thread size is smaller than the wrench flat width at least half of the wrench flat must be located on the rod diameter.)

# Air DX Deluxe Rod™ Cylinders Program

**Table 1**  
**External Threads**  
(Thread sizes available on DX options)

English (Class 2 Fit)		Metric (H6 Fit)					
Model 4 & 3	Model 75	Model 25 & 5	Model 6	Model 7	Model 8	#8-32 UNC	M3 x .50
						#8-36 UNF	M4 x .7
						#10-24 UNC	M5 x .80
						#10-32 UNF	M6 x 1.00
						1/4-20 UNC	M8 x 1.25
						1/4-28 UNF	M8 x 1.00
						5/16-18 UNC	M10 x 1.50
						5/16-24 UNF	M10 x 1.25
						3/8-16 UNC	M12 x 1.75
						3/8-24 UNF	M12 x 1.50
						7/16-14 UNC	M14 x 2.00
						7/16-20 UNF	M14 x 1.50
						1/2-13 UNC	M15 x 1.00
						1/2-20 UNF	M16 x 2.00
						9/16-12 UNC	M16 x 1.50
						9/16-18 UNF	
						5/8-11 UNC	
						5/8-18 UNF	

**Table 2**  
**Internal Threads**  
(Internal threads available for the DX options)  
(Internal Metric Threads not Available)  
(Not Available on Models 8 & 7)

**English**  
(Class 2 Fit)

#8-32 UNC  
#8-36 UNF  
#10-24 UNC maximum internal threads  
#10-32 UNF Model 6  
1/4-20 UNC  
1/4-28 UNF Model 5, 25, & 75  
5/16-18 UNC  
5/16-24 UNF  
3/8-16 UNC  
3/8-24 UNF Model 3 & 4

**Table 3**  
**Cross-hole Sizes**  
(The size of cross-hole available depends on the model)

	.078"	.141"
Model 3	•	•
Model 4	•	•
Model 75	•	•
Model 5	•	•
Model 25	•	•
Model 6	•	NA
Model 7	•	NA
Model 8	•	NA

• - Hole available  
If hole falls on threaded portion of rod the hole size must be at most 40% of basic thread size.

NA - Hole not available for this model

.078" hole for 1/16" cotter pin  
.141" hole for 1/8" cotter pin

# Air DX Deluxe Rod™ Cylinders Program

**Table 4  
Boxed Dimensions**

(Definitions of the boxed dimensions on the order sheets)  
(Boxed dimensions are determined by cylinder model and are not modifiable under this program.)

- B** - Corner Break Size
- F** - Width Across Flats (Wrench size)
- FA** - Flat Length
- R** - Rod Diameter
- S** - Screwdriver Slot Size (SEE DX10 for slot sizes)
- 3/2 (s)** - Depth of Screwdriver Slot

	<b>B</b>	<b>F</b>	<b>FA</b>	<b>R</b>
Model 3	.015	.500	.278	.625
Model 4	.015	.500	.278	.625
Model 75	.015	.438	.278	.500
Model 5	.015	.375	.275	.437
Model 25	.015	.375	.275	.437
Model 6	.015	.250	.188	.312
Model 7	.015	.219	.188	.250
Model 8	.015	NA	NA	.187

**Table 5  
Standard ("Std") Dimensions**

**Round Heads**

	<b>D</b>	<b>FD</b>	<b>J</b>	<b>JL</b>
Model 8	.50	NA	10-32	.50
Model 7	.50	NA	1/4-28	.50
Model 6	.62	.60	5/16-24	.50
Model 25	1.00	.93	7/16-20	.75
Model 5	1.00	.93	7/16-20	.75
Model 75	1.19	1.14	1/2-20	.88
Model 4	1.25	1.15	1/2-20	.88
Model 3	1.25	1.15	1/2-20	.88

**Block Mount Heads**

	<b>D</b>	<b>FD</b>	<b>J</b>	<b>JL</b>
Model 8	.50	NA	10-32	.50
Model 7	1.06	1.01	1/4-28	.75
Model 6	1.12	1.01	5/16-24	.75
Model 25	NA	NA	NA	NA
Model 5	1.50	1.43	7/16-20	1.25
Model 75	NA	NA	NA	NA
Model 4	NA	NA	NA	NA
Model 3	NA	NA	NA	NA

# Air DX Deluxe Rod™ Cylinders Program

Distributor Name:	Contact Person:	PO#	<b>DX10</b>
Customer Name:	Contact Person:	PO#	
Ship To Address:	Requested Ship Date:		
	Model, Type, Stroke, and Options:		Qty:

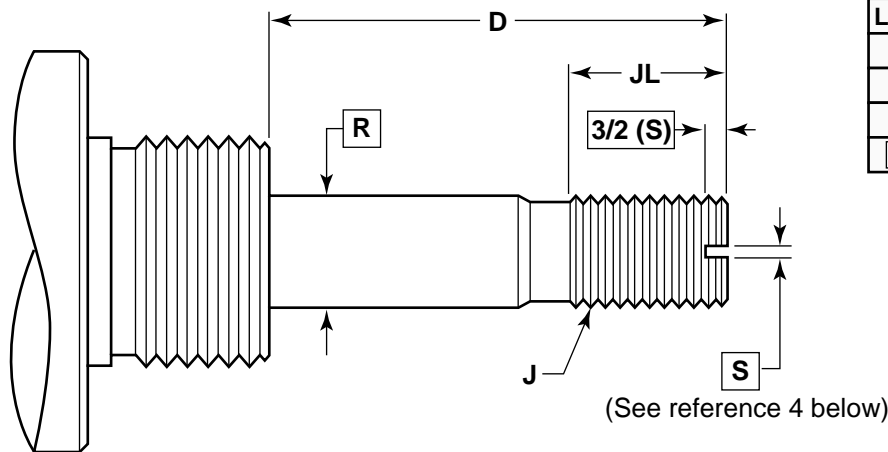

LETTER	SIZE	Ref.
D		1.
J		2.
JL		3.
S		4.

**Below for Humphrey use only:**

Entered By:	Date:	Order Number:	Tracking #:	Delivery Date:	Price:
-------------	-------	---------------	-------------	----------------	--------

DX10: Available on all cylinder models (prefix #8 through prefix #3). Metric allowed for "J." All other dimensions are to be in inches.

Purpose: Allows user to specify thread definition and length on a rod of variable length, and to have a screw driver slot placed on the end. See Table 4 for boxed dimension definitions except S which appears below in reference 4.

References

- D >= 0 and D <= 6.0  
(Rod extension must be greater than or equal to 0.00" and less than or equal to 6.00")
- J: There are two parts; Size and Threads Per Inch. Choose the thread desired from Table 1. Place the description for the thread size desired in this box. Maximum thread size for your model can be determined by referring to Table 1.
- JL: Length of threads  
 $JL \leq 6 \times \text{"J" Size (decimal format)}$  and  
 If U.S. thread:  $JL \leq D - (2.0 \div \text{"J" Pitch})$   
 If Metric thread:  $JL \leq D - (2.0 \times \text{"J" Pitch converted to inches})$   
 Minimum U.S. External Thread Length =  $3 \div \text{"J" Pitch}$

Minimum Metric External Thread Length =  $3 \times \text{"J" Pitch converted to inches}$

Example: Desired thread is 5/16-18

$JL \geq 3 \div 18$  and  
 $JL \leq 6.0 \times 5/16$  and  
 $JL \leq D - (2.0 \div 18.0)$

(These constraints ensure the following:

- Proper pitch can be maintained over the full length of thread.
- Thread length will not enter the nose/bearing of front head
- Thread length will leave room for proper turn diameter including chamfer.)

4. S = .047 if "J" Size <= 5/16 (U.S. Threads) or M8 (Metric Threads)

S = .094 if "J" Size > 5/16 (U.S. Threads) or M8 (Metric Threads)  
 (Use this constraint to determine available screwdriver slot width.)



# Air DX Deluxe Rod™ Cylinders Program

**Table 1**  
**External Threads**  
(Thread sizes available on DX options)

	<b>English</b> (Class 2 Fit)	<b>Metric</b> (H6 Fit)	
Model 4 & 3	Model 75 Model 25 & 5 Model 6 Model 7 Model 8	#8-32 UNC	M3 x .50
		#8-36 UNF	M4 x .7
		#10-24 UNC	M5 x .80
		#10-32 UNF	M6 x 1.00
		1/4-20 UNC	M8 x 1.25
		1/4-28 UNF	M8 x 1.00
		5/16-18 UNC	M10 x 1.50
		5/16-24 UNF	M10 x 1.25
		3/8-16 UNC	M12 x 1.75
		3/8-24 UNF	M12 x 1.50
		7/16-14 UNC	M14 x 2.00
		7/16-20 UNF	M14 x 1.50
		1/2-13 UNC	M15 x 1.00
		1/2-20 UNF	M16 x 2.00
Model 4 & 3	Model 75 Model 25 & 5 Model 6 Model 7 Model 8	9/16-12 UNC	M16 x 1.50
		9/16-18 UNF	
		5/8-11 UNC	
		5/8-18 UNF	

**Table 2**  
**Internal Threads**  
(Internal threads available for the DX options)  
(Internal Metric Threads not Available)  
(Not Available on Models 8 & 7)

<b>English</b> (Class 2 Fit)
#8-32 UNC
#8-36 UNF
#10-24 UNC maximum internal threads
#10-32 UNF Model 6
1/4-20 UNC
1/4-28 UNF Model 5, 25, & 75
5/16-18 UNC
5/16-24 UNF
3/8-16 UNC
3/8-24 UNF Model 3 & 4

**Table 3**  
**Cross-hole Sizes**  
(The size of cross-hole available depends on the model)

	.078"	.141"
Model 3	•	•
Model 4	•	•
Model 75	•	•
Model 5	•	•
Model 25	•	•
Model 6	•	NA
Model 7	•	NA
Model 8	•	NA

• - Hole available  
If hole falls on threaded portion of rod the hole size must be at most 40% of basic thread size.

NA - Hole not available for this model

.078" hole for 1/16" cotter pin  
.141" hole for 1/8" cotter pin

# Air DX Deluxe Rod™ Cylinders Program

**Table 4  
Boxed Dimensions**

(Definitions of the boxed dimensions on the order sheets)  
(Boxed dimensions are determined by cylinder model and are not modifiable under this program.)

- B** - Corner Break Size
- F** - Width Across Flats (Wrench size)
- FA** - Flat Length
- R** - Rod Diameter
- S** - Screwdriver Slot Size (SEE DX10 for slot sizes)
- 3/2 (s)** - Depth of Screwdriver Slot

	<b>B</b>	<b>F</b>	<b>FA</b>	<b>R</b>
Model 3	.015	.500	.278	.625
Model 4	.015	.500	.278	.625
Model 75	.015	.438	.278	.500
Model 5	.015	.375	.275	.437
Model 25	.015	.375	.275	.437
Model 6	.015	.250	.188	.312
Model 7	.015	.219	.188	.250
Model 8	.015	NA	NA	.187

**Table 5  
Standard ("Std") Dimensions**

**Round Heads**

	<b>D</b>	<b>FD</b>	<b>J</b>	<b>JL</b>
Model 8	.50	NA	10-32	.50
Model 7	.50	NA	1/4-28	.50
Model 6	.62	.60	5/16-24	.50
Model 25	1.00	.93	7/16-20	.75
Model 5	1.00	.93	7/16-20	.75
Model 75	1.19	1.14	1/2-20	.88
Model 4	1.25	1.15	1/2-20	.88
Model 3	1.25	1.15	1/2-20	.88

**Block Mount Heads**

	<b>D</b>	<b>FD</b>	<b>J</b>	<b>JL</b>
Model 8	.50	NA	10-32	.50
Model 7	1.06	1.01	1/4-28	.75
Model 6	1.12	1.01	5/16-24	.75
Model 25	NA	NA	NA	NA
Model 5	1.50	1.43	7/16-20	1.25
Model 75	NA	NA	NA	NA
Model 4	NA	NA	NA	NA
Model 3	NA	NA	NA	NA

# Air DX Deluxe Rod™ Cylinders Program

<b>Distributor Name:</b>		<b>Contact Person:</b>		<b>PO#</b>		<b>DX09</b>
<b>Customer Name:</b>		<b>Contact Person:</b>		<b>PO#</b>		
<b>Ship To Address:</b>	<b>Requested Ship Date:</b>					
	<b>Model, Type, Stroke, and Options:</b>				<b>Qty:</b>	

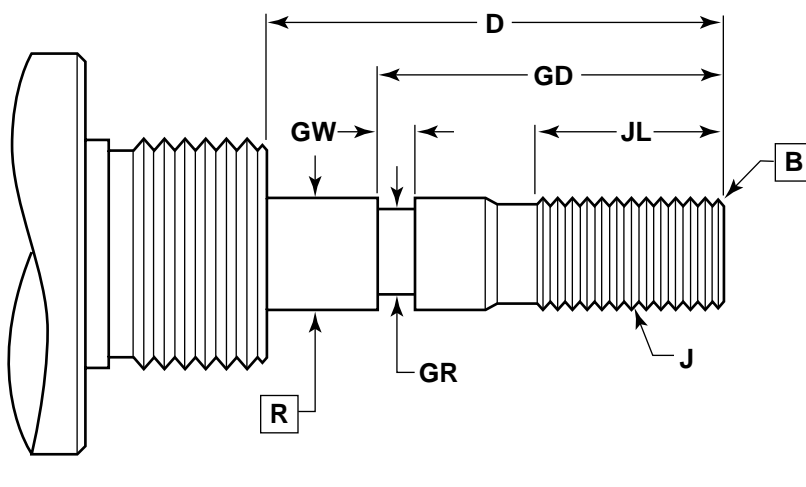

LETTER	SIZE	Ref.
D		1.
GR		2.
GD		3.
GW		4.
J		5.
JL		6.

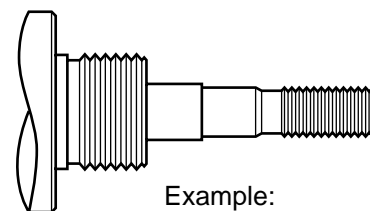

Example:

**Below for Humphrey use only:**

<b>Entered By:</b>	<b>Date:</b>	<b>Order Number:</b>	<b>Tracking #:</b>	<b>Delivery Date:</b>	<b>Price:</b>
--------------------	--------------	----------------------	--------------------	-----------------------	---------------

DX09: Available on all cylinder models (prefix #8 through prefix #3.) Metric allowed for "J" All other dimensions are to be in inches.

Purpose: Allows user to specify the location and width of a groove, along with the ability to specify thread information (length and type), plus specify the overall length of the rod. See Table 4 for boxed dimension definitions.

References

1.  $D \geq 0$  and  $D \leq 6.0$   
(Rod extension must be greater than or equal to 0.00" and less than or equal to 6.00")
2.  $GR \geq .6 \times R$  and  $GR < R$   
(For proper strength of the rod in the groove area, 60% of the original rod diameter must remain.)
3.  $GD \leq D$  and  
If U.S.Threads Then  
GD must be greater than or equal to  $JL + GW + (2 \div "J" \text{ Pitch})$   
Else (Metric threads)  
GD must be greater than or equal to  $JL + GW + (2 \times "J" \text{ Pitch converted to inches})$   
(This constraint prohibits the groove from entering nose and/or bearing and also ensures enough room for run-out of thread and chamfer before entering groove width area.)
4.  $GW \geq .030$  (minimum groove width) and  
If "J" Size  $> GR$  Then

If U.S.Threads Then  
GW must be less than equal to  $GD - JL - (2 \div "J" \text{ Pitch})$   
Else (Metric Threads)  
GW must be less than equal to  $GD - JL - (2 \times "J" \text{ Pitch converted to inches})$   
(Ensures that if the thread diameter is larger than the groove width diameter, the groove may not enter the threaded area.)

5. J: There are two parts: Size and Threads Per Inch. Choose the thread desired from Table 1. Place the description of the thread size desired in this box. Maximum thread size for a model can be determined by referring to Table 1.
6. JL: Length of the threads  
 $JL \leq 6 \times "J" \text{ Size (decimal format) and}$   
If U.S. thread:  $JL \leq D - (2.0 \div "J" \text{ Pitch})$   
If Metric thread:  $JL \leq D - (2.0 \times "1" \text{ Pitch converted to inches})$

Minimum U.S. External Thread Length =  $3 \div "J" \text{ Pitch (Threads Per Inch)}$   
Minimum Metric External Thread Length =  $3 \times "J" \text{ Pitch converted to inches}$

Example: Desired thread is 5/16-18  
 $JL \geq 3 \div 18$  and  
 $JL \leq 6.0 \times 5/16$  and  
 $JL \leq D - (2.0 \div 18.0)$

- (These constraints ensure the following:  
A. Proper pitch can be maintained over the full length of thread.  
B. Thread length will not enter the nose/bearing of front head.  
C. Thread length will leave room for proper turn diameter including chamfer.)

# Air DX Deluxe Rod™ Cylinders Program

**Table 1**  
**External Threads**  
(Thread sizes available on DX options)

	<b>English</b> (Class 2 Fit)	<b>Metric</b> (H6 Fit)					
Model 4 & 3	Model 75	Model 25 & 5	Model 6	Model 7	Model 8	#8-32 UNC	M3 x .50
						#8-36 UNF	M4 x .7
						#10-24 UNC	M5 x .80
						#10-32 UNF	M6 x 1.00
						1/4-20 UNC	M8 x 1.25
						1/4-28 UNF	M8 x 1.00
						5/16-18 UNC	M10 x 1.50
						5/16-24 UNF	M10 x 1.25
						3/8-16 UNC	M12 x 1.75
						3/8-24 UNF	M12 x 1.50
Model 4 & 3	Model 75	Model 25 & 5	Model 6	Model 7	Model 8	7/16-14 UNC	M14 x 2.00
						7/16-20 UNF	M14 x 1.50
						1/2-13 UNC	M15 x 1.00
						1/2-20 UNF	M16 x 2.00
						9/16-12 UNC	M16 x 1.50
						9/16-18 UNF	
						5/8-11 UNC	
						5/8-18 UNF	

**Table 2**  
**Internal Threads**  
(Internal threads available for the DX options)  
(Internal Metric Threads not Available)  
(Not Available on Models 8 & 7)

<b>English</b> (Class 2 Fit)
#8-32 UNC
#8-36 UNF
#10-24 UNC maximum internal threads
#10-32 UNF Model 6
1/4-20 UNC
1/4-28 UNF Model 5, 25, & 75
5/16-18 UNC
5/16-24 UNF
3/8-16 UNC
3/8-24 UNF Model 3 & 4

**Table 3**  
**Cross-hole Sizes**  
(The size of cross-hole available depends on the model)

	.078"	.141"
Model 3	•	•
Model 4	•	•
Model 75	•	•
Model 5	•	•
Model 25	•	•
Model 6	•	NA
Model 7	•	NA
Model 8	•	NA

• - Hole available  
If hole falls on threaded portion of rod the hole size must be at most 40% of basic thread size.

NA - Hole not available for this model

.078" hole for 1/16" cotter pin  
.141" hole for 1/8" cotter pin

# Air DX Deluxe Rod™ Cylinders Program

**Table 4  
Boxed Dimensions**

(Definitions of the boxed dimensions on the order sheets)  
(Boxed dimensions are determined by cylinder model and are not modifiable under this program.)

- B** - Corner Break Size
- F** - Width Across Flats (Wrench size)
- FA** - Flat Length
- R** - Rod Diameter
- S** - Screwdriver Slot Size (SEE DX10 for slot sizes)
- 3/2 (s)** - Depth of Screwdriver Slot

	<b>B</b>	<b>F</b>	<b>FA</b>	<b>R</b>
Model 3	.015	.500	.278	.625
Model 4	.015	.500	.278	.625
Model 75	.015	.438	.278	.500
Model 5	.015	.375	.275	.437
Model 25	.015	.375	.275	.437
Model 6	.015	.250	.188	.312
Model 7	.015	.219	.188	.250
Model 8	.015	NA	NA	.187

**Table 5  
Standard ("Std") Dimensions**

**Round Heads**

	<b>D</b>	<b>FD</b>	<b>J</b>	<b>JL</b>
Model 8	.50	NA	10-32	.50
Model 7	.50	NA	1/4-28	.50
Model 6	.62	.60	5/16-24	.50
Model 25	1.00	.93	7/16-20	.75
Model 5	1.00	.93	7/16-20	.75
Model 75	1.19	1.14	1/2-20	.88
Model 4	1.25	1.15	1/2-20	.88
Model 3	1.25	1.15	1/2-20	.88

**Block Mount Heads**

	<b>D</b>	<b>FD</b>	<b>J</b>	<b>JL</b>
Model 8	.50	NA	10-32	.50
Model 7	1.06	1.01	1/4-28	.75
Model 6	1.12	1.01	5/16-24	.75
Model 25	NA	NA	NA	NA
Model 5	1.50	1.43	7/16-20	1.25
Model 75	NA	NA	NA	NA
Model 4	NA	NA	NA	NA
Model 3	NA	NA	NA	NA

# Air DX Deluxe Rod™ Cylinders Program

Distributor Name:	Contact Person:	PO#	<b>DX08</b>
Customer Name:	Contact Person:	PO#	
Ship To Address:	Requested Ship Date:		
	Model, Type, Stroke, and Options:	Qty:	

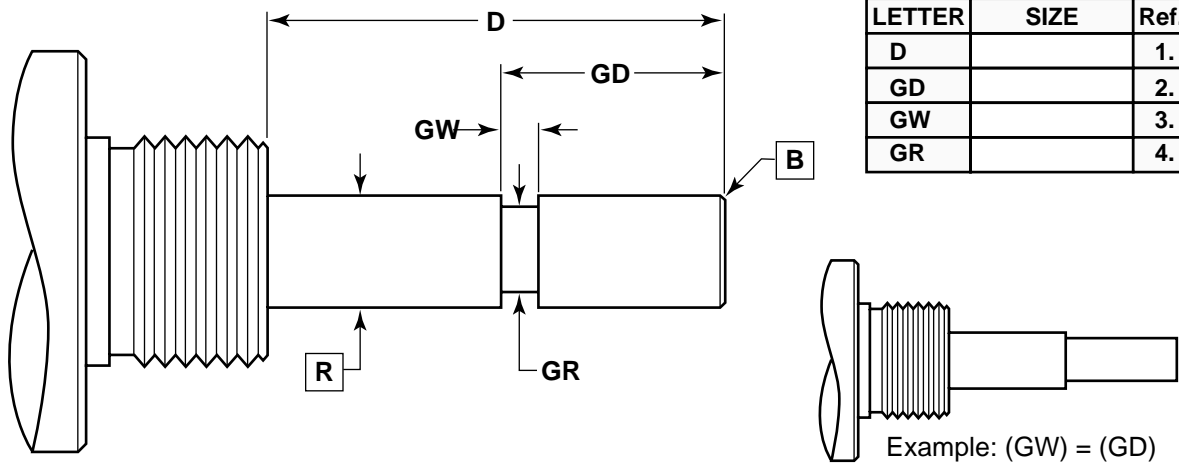

**Below for Humphrey use only:**

Entered By:	Date:	Order Number:	Tracking #:	Delivery Date:	Price:
-------------	-------	---------------	-------------	----------------	--------

DX08: Available on all cylinder models (prefix #8 through prefix #3). All dimensions are to be in inches.

Purpose: Allows user to specify the location and width of a groove on a rod of varying length. See Table 4 for boxed dimension defections. If  $GD = GW$  the rod will simply contain a step down. See above example.

References

1.  $D \geq 0$  and  
 $D \leq 6.0$   
 (Rod extension must be greater than or equal to 0.00" and Less than or equal to 6.00")
2.  $GD \geq .030$  (minimum groove width) and  
 $GD \leq D$   
 (This constraint ensures that the groove will not enter the nose and/or the rod bearing.)
3.  $GW \geq .030$  (minimum groove width) and  
 $GW \leq GD$   
 (This constraint ensures proper width of the groove and that the groove width remains within GD.)
4.  $GR \geq .6 \times R$  and  
 $GR < R$   
 (For proper strength of the rod in the groove area, 60% of the original rod diameter must remain.)

# Air DX Deluxe Rod™ Cylinders Program

**Table 1**  
**External Threads**  
(Thread sizes available on DX options)

	<b>English</b> (Class 2 Fit)	<b>Metric</b> (H6 Fit)					
Model 4 & 3	Model 75	Model 25 & 5	Model 6	Model 7	Model 8	#8-32 UNC	M3 x .50
						#8-36 UNF	M4 x .7
						#10-24 UNC	M5 x .80
						#10-32 UNF	M6 x 1.00
						1/4-20 UNC	M8 x 1.25
						1/4-28 UNF	M8 x 1.00
						5/16-18 UNC	M10 x 1.50
						5/16-24 UNF	M10 x 1.25
						3/8-16 UNC	M12 x 1.75
						3/8-24 UNF	M12 x 1.50
Model 4 & 3	Model 75	Model 25 & 5	Model 6	Model 7	Model 8	7/16-14 UNC	M14 x 2.00
						7/16-20 UNF	M14 x 1.50
						1/2-13 UNC	M15 x 1.00
						1/2-20 UNF	M16 x 2.00
						9/16-12 UNC	M16 x 1.50
						9/16-18 UNF	
						5/8-11 UNC	
						5/8-18 UNF	

**Table 2**  
**Internal Threads**  
(Internal threads available for the DX options)  
(Internal Metric Threads not Available)  
(Not Available on Models 8 & 7)

<b>English</b> (Class 2 Fit)
#8-32 UNC
#8-36 UNF
#10-24 UNC maximum internal threads
#10-32 UNF Model 6
1/4-20 UNC
1/4-28 UNF Model 5, 25, & 75
5/16-18 UNC
5/16-24 UNF
3/8-16 UNC
3/8-24 UNF Model 3 & 4

**Table 3**  
**Cross-hole Sizes**  
(The size of cross-hole available depends on the model)

	.078"	.141"
Model 3	•	•
Model 4	•	•
Model 75	•	•
Model 5	•	•
Model 25	•	•
Model 6	•	NA
Model 7	•	NA
Model 8	•	NA

• - Hole available  
If hole falls on threaded portion of rod the hole size must be at most 40% of basic thread size.

NA - Hole not available for this model

.078" hole for 1/16" cotter pin  
.141" hole for 1/8" cotter pin

# Air DX Deluxe Rod™ Cylinders Program

**Table 4  
Boxed Dimensions**

(Definitions of the boxed dimensions on the order sheets)  
(Boxed dimensions are determined by cylinder model and are not modifiable under this program.)

- B** - Corner Break Size
- F** - Width Across Flats (Wrench size)
- FA** - Flat Length
- R** - Rod Diameter
- S** - Screwdriver Slot Size (SEE DX10 for slot sizes)
- 3/2 (s)** - Depth of Screwdriver Slot

	<b>B</b>	<b>F</b>	<b>FA</b>	<b>R</b>
Model 3	.015	.500	.278	.625
Model 4	.015	.500	.278	.625
Model 75	.015	.438	.278	.500
Model 5	.015	.375	.275	.437
Model 25	.015	.375	.275	.437
Model 6	.015	.250	.188	.312
Model 7	.015	.219	.188	.250
Model 8	.015	NA	NA	.187

**Table 5  
Standard ("Std") Dimensions**

**Round Heads**

	<b>D</b>	<b>FD</b>	<b>J</b>	<b>JL</b>
Model 8	.50	NA	10-32	.50
Model 7	.50	NA	1/4-28	.50
Model 6	.62	.60	5/16-24	.50
Model 25	1.00	.93	7/16-20	.75
Model 5	1.00	.93	7/16-20	.75
Model 75	1.19	1.14	1/2-20	.88
Model 4	1.25	1.15	1/2-20	.88
Model 3	1.25	1.15	1/2-20	.88

**Block Mount Heads**

	<b>D</b>	<b>FD</b>	<b>J</b>	<b>JL</b>
Model 8	.50	NA	10-32	.50
Model 7	1.06	1.01	1/4-28	.75
Model 6	1.12	1.01	5/16-24	.75
Model 25	NA	NA	NA	NA
Model 5	1.50	1.43	7/16-20	1.25
Model 75	NA	NA	NA	NA
Model 4	NA	NA	NA	NA
Model 3	NA	NA	NA	NA

# DX Deluxe Rod™ Cylinders Program

<b>Distributor Name:</b>		<b>Contact Person:</b>		<b>PO#</b>		<b>DX07</b>
<b>Customer Name:</b>		<b>Contact Person:</b>		<b>PO#</b>		
<b>Ship To Address:</b>			<b>Requested Ship Date:</b>			
			<b>Model, Type, Stroke, and Options:</b>		<b>Qty:</b>	

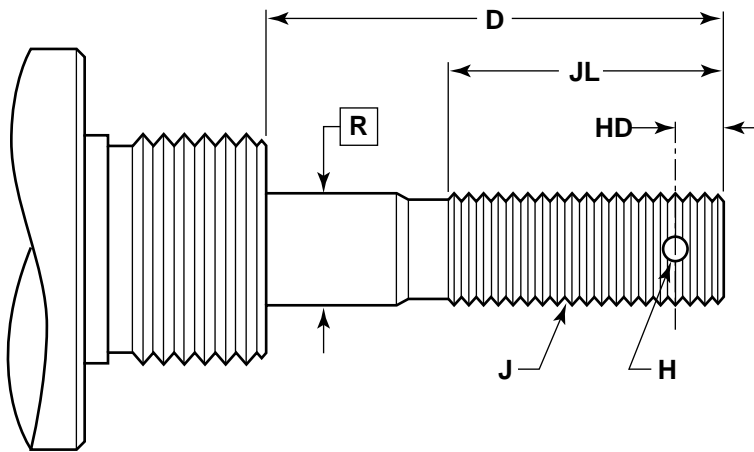

LETTER	SIZE	Ref.
D		1.
HD		2.
H		3.
J		4.
JL		5.

**Below for Humphrey use only:**

<b>Entered By:</b>	<b>Date:</b>	<b>Order Number:</b>	<b>Tracking #:</b>	<b>Delivery Date:</b>	<b>Price:</b>
--------------------	--------------	----------------------	--------------------	-----------------------	---------------

DX07: Available on all cylinder models (prefix #8 through #3). Metric allowed for "J" size. All other dimensions are to be in inches.

Purpose: Allows user to specify a thread definition, plus a cotter pin cross hole, on a rod of varying length. See Table 4 for boxed dimension definitions.

References

- D >= 0 and D <= 6.0  
(Rod extension must be greater than or equal to 0.00" and less than or equal to 6.00")
- HD >= (1/2 x H) + .030 (minimum wall thickness around hole) and HD <= D - (1/2 x H) and  
If U.S.Threads Then  
HD must be less than or equal to JL + (2 ÷ "J" Pitch) - (1/2 x H) or  
HD must be greater than JL + (2 ÷ "J" Pitch) + (1/2 x H) + .030 .(min. wall thick. around hole)  
Else (Metric threads)  
HD must be less than or equal to JL + (2 x "J" Pitch converted to inches⊕) - (1/2x H) or  
HD must be greater than JL + (2 x "J" Pitch converted to inches⊕) + (1/2 x H) + .030 (min. wall thick. around hole)  
(This constraint ensures that the cross-drilled hole will not break out of the end of the rod or enter nose and/or rod bearing and that the hole does not appear on the step-down angle for the threaded area.)
- H = .078 or .141 depending on the model and thread size. See Table 3 for hole sizes.  
If HD < JL + (1/2 x H) + [(2 ÷ "J" Pitch) if U.S. Threads, (2 x "J"

Pitch converted to inches.⊕) if Metric Threads] Then H must be less than or equal to .4 x "J" Size  
(A smaller than standard thread size may prohibit inclusion of the larger hole)

- J: There are two parts: Size and Threads Per Inch. Choose the thread desired from Table 1. Place the description for the thread size desired in this box. Maximum thread size for your model can be determined by referring to Table 1.

JL: Length of the threads  
JL <= 6 x "J" Size (decimal format) and  
If U.S. thread: JL <= D - (2.0 ÷ "J" Pitch)  
If Metric thread: JL <= D - (2.0 x "J" Pitch converted to inches⊕)

Minimum U.S. External Thread Length = 3 ÷ "J" Pitch (Threads Per Inch)

Minimum Metric External Thread Length = 3 x "J" Pitch converted to inches⊕

Example: Desired thread is 5/16-18

$$JL >= 3/18 \text{ and}$$

$$JL <= 6.0 \times 5/16 \text{ and}$$

$$JL <= D - (2.0 \div 18.0)$$

(These constraints ensure the following:

- Proper pitch can be maintained over the full length of thread
- Thread length will not enter the nose/bearing of front head
- Thread length will leave room for proper turn diameter including chamfer.)

# Air DX Deluxe Rod™ Cylinders Program

**Table 1**  
**External Threads**  
(Thread sizes available on DX options)

	<b>English</b> (Class 2 Fit)	<b>Metric</b> (H6 Fit)		
Model 4 & 3	Model 75 Model 25 & 5 Model 6 Model 7 Model 8	Model 75 Model 25 & 5 Model 6 Model 7 Model 8	#8-32 UNC	M3 x .50
			#8-36 UNF	M4 x .7
			#10-24 UNC	M5 x .80
			#10-32 UNF	M6 x 1.00
			1/4-20 UNC	M8 x 1.25
			1/4-28 UNF	M8 x 1.00
			5/16-18 UNC	M10 x 1.50
			5/16-24 UNF	M10 x 1.25
			3/8-16 UNC	M12 x 1.75
			3/8-24 UNF	M12 x 1.50
			7/16-14 UNC	M14 x 2.00
			7/16-20 UNF	M14 x 1.50
			1/2-13 UNC	M15 x 1.00
			1/2-20 UNF	M16 x 2.00
			9/16-12 UNC	M16 x 1.50
			9/16-18 UNF	
5/8-11 UNC				
5/8-18 UNF				

**Table 2**  
**Internal Threads**  
(Internal threads available for the DX options)  
(Internal Metric Threads not Available)  
(Not Available on Models 8 & 7)

<b>English</b> (Class 2 Fit)
#8-32 UNC
#8-36 UNF
#10-24 UNC maximum internal threads
#10-32 UNF Model 6
1/4-20 UNC
1/4-28 UNF Model 5, 25, & 75
5/16-18 UNC
5/16-24 UNF
3/8-16 UNC
3/8-24 UNF Model 3 & 4

**Table 3**  
**Cross-hole Sizes**  
(The size of cross-hole available depends on the model)

	.078"	.141"
Model 3	•	•
Model 4	•	•
Model 75	•	•
Model 5	•	•
Model 25	•	•
Model 6	•	NA
Model 7	•	NA
Model 8	•	NA

• - Hole available  
If hole falls on threaded portion of rod the hole size must be at most 40% of basic thread size.

NA - Hole not available for this model

.078" hole for 1/16" cotter pin  
.141" hole for 1/8" cotter pin

# Air DX Deluxe Rod™ Cylinders Program

**Table 4  
Boxed Dimensions**

(Definitions of the boxed dimensions on the order sheets)  
(Boxed dimensions are determined by cylinder model and are not modifiable under this program.)

- B** - Corner Break Size
- F** - Width Across Flats (Wrench size)
- FA** - Flat Length
- R** - Rod Diameter
- S** - Screwdriver Slot Size (SEE DX10 for slot sizes)
- 3/2 (s)** - Depth of Screwdriver Slot

	<b>B</b>	<b>F</b>	<b>FA</b>	<b>R</b>
Model 3	.015	.500	.278	.625
Model 4	.015	.500	.278	.625
Model 75	.015	.438	.278	.500
Model 5	.015	.375	.275	.437
Model 25	.015	.375	.275	.437
Model 6	.015	.250	.188	.312
Model 7	.015	.219	.188	.250
Model 8	.015	NA	NA	.187

**Table 5  
Standard ("Std") Dimensions**

**Round Heads**

	<b>D</b>	<b>FD</b>	<b>J</b>	<b>JL</b>
Model 8	.50	NA	10-32	.50
Model 7	.50	NA	1/4-28	.50
Model 6	.62	.60	5/16-24	.50
Model 25	1.00	.93	7/16-20	.75
Model 5	1.00	.93	7/16-20	.75
Model 75	1.19	1.14	1/2-20	.88
Model 4	1.25	1.15	1/2-20	.88
Model 3	1.25	1.15	1/2-20	.88

**Block Mount Heads**

	<b>D</b>	<b>FD</b>	<b>J</b>	<b>JL</b>
Model 8	.50	NA	10-32	.50
Model 7	1.06	1.01	1/4-28	.75
Model 6	1.12	1.01	5/16-24	.75
Model 25	NA	NA	NA	NA
Model 5	1.50	1.43	7/16-20	1.25
Model 75	NA	NA	NA	NA
Model 4	NA	NA	NA	NA
Model 3	NA	NA	NA	NA

# Air DX Deluxe Rod™ Cylinders Program

Distributor Name:	Contact Person:	PO#	<b>DX06</b>
Customer Name:	Contact Person:	PO#	
Ship To Address:	Requested Ship Date:		
	Model, Type, Stroke, and Options:	Qty:	

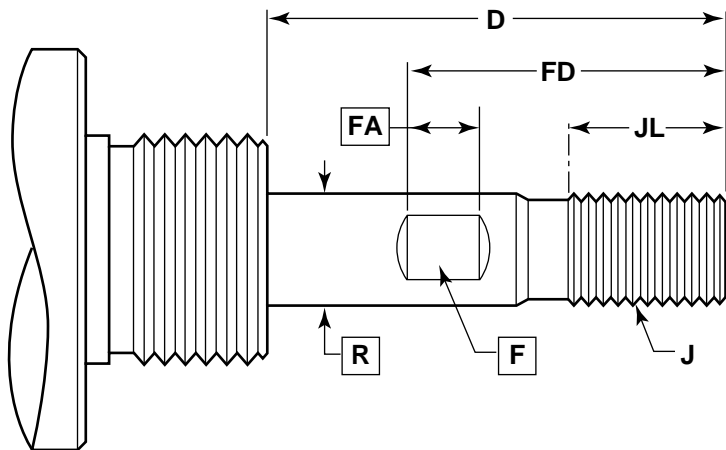

LETTER	SIZE	Ref.
D		1.
J		2.
JL		3.
FD		4.

### Below for Humphrey use only:

Entered By:	Date:	Order Number:	Tracking #:	Delivery Date:	Price:
-------------	-------	---------------	-------------	----------------	--------

DX06: Not available on model #8. Metric allowed for "J." All other dimensions are to be in inches.

Purpose: Allows user to specify thread definition, and a wrench flat location on a rod of variable length. The DX06 option is most like the Humphrey standard cylinder rod end. See Table 4 for boxed dimension definitions.

#### References

1.  $D \geq 0$  and  $D \leq 6.0$   
(Rod extension must be greater than or equal to 0.00" and less than or equal to 6.00")
2. J: There are two parts: Size and Threads Per Inch. Choose the thread desired from Table 1. Place the description for the thread size desired in this box. Maximum thread size for your model can be determined by referring to Table 1.
3. JL: Length of the threads  
 $JL \leq 6 \times \text{"J" Size (decimal format)}$  and  
 If U.S. thread:  $JL \leq D - (2.0 \div \text{"J" Pitch})$   
 If Metric thread:  $JL \leq D - (2.0 \times \text{"J" Pitch converted to inches})$

Minimum U.S. External Thread Length =  $3 \div \text{"J" Pitch (Threads Per Inch)}$ , Minimum Metric External Thread Length =  $3 \times \text{"J" Pitch converted to inches}$   
 Example: Desired thread is 5/16-18

$$JL \geq 3 \div 18 \text{ and}$$

$$JL \leq 6.0 \times 5/16 \text{ and}$$

$$JL \leq D - (2.0 \div 18.0)$$

(These constraints ensure the following:

- A. Proper pitch can be maintained over the full length of thread.
- B. thread length will not enter the nose/bearing of front head.
- C. Thread length will leave room for proper turn diameter including chamfer.)

4.  $FD \leq D$  and  $FD \geq FA$  and  
 If  $F > \text{"J" Size}$  Then  
 If U.S. threads Then  
 $FD \geq (FA \div 2) + JL + (2 \div \text{"J" Pitch})$   
 Else (Metric Threads)  
 $FD \geq (FA \div 2) + JL + (2 \times \text{"J" Pitch converted to inches})$

(These constraints ensure the following:

- A. The wrench flat cannot enter the nose and/or the bearing.
- B. The rod will contain the entire wrench flat.
- C. When the thread size is smaller than the wrench flat width, at least half of the wrench flat must be located on the rod diameter.)

# Air DX Deluxe Rod™ Cylinders Program

**Table 1**  
**External Threads**  
(Thread sizes available on DX options)

	English (Class 2 Fit)	Metric (H6 Fit)					
Model 4 & 3	Model 75	Model 25 & 5	Model 6	Model 7	Model 8	#8-32 UNC	M3 x .50
						#8-36 UNF	M4 x .7
						#10-24 UNC	M5 x .80
						#10-32 UNF	M6 x 1.00
						1/4-20 UNC	M8 x 1.25
						1/4-28 UNF	M8 x 1.00
						5/16-18 UNC	M10 x 1.50
						5/16-24 UNF	M10 x 1.25
						3/8-16 UNC	M12 x 1.75
						3/8-24 UNF	M12 x 1.50
Model 4 & 3	Model 75	Model 25 & 5	Model 6	Model 7	Model 8	7/16-14 UNC	M14 x 2.00
						7/16-20 UNF	M14 x 1.50
						1/2-13 UNC	M15 x 1.00
						1/2-20 UNF	M16 x 2.00
						9/16-12 UNC	M16 x 1.50
						9/16-18 UNF	
						5/8-11 UNC	
						5/8-18 UNF	

**Table 2**  
**Internal Threads**  
(Internal threads available for the DX options)  
(Internal Metric Threads not Available)  
(Not Available on Models 8 & 7)

English (Class 2 Fit)
#8-32 UNC
#8-36 UNF
#10-24 UNC maximum internal threads
#10-32 UNF Model 6
1/4-20 UNC
1/4-28 UNF Model 5, 25, & 75
5/16-18 UNC
5/16-24 UNF
3/8-16 UNC
3/8-24 UNF Model 3 & 4

**Table 3**  
**Cross-hole Sizes**  
(The size of cross-hole available depends on the model)

	.078"	.141"
Model 3	•	•
Model 4	•	•
Model 75	•	•
Model 5	•	•
Model 25	•	•
Model 6	•	NA
Model 7	•	NA
Model 8	•	NA

• - Hole available  
If hole falls on threaded portion of rod the hole size must be at most 40% of basic thread size.

NA - Hole not available for this model

.078" hole for 1/16" cotter pin  
.141" hole for 1/8" cotter pin

# Air DX Deluxe Rod™ Cylinders Program

**Table 4  
Boxed Dimensions**

(Definitions of the boxed dimensions on the order sheets)  
(Boxed dimensions are determined by cylinder model and are not modifiable under this program.)

- B** - Corner Break Size
- F** - Width Across Flats (Wrench size)
- FA** - Flat Length
- R** - Rod Diameter
- S** - Screwdriver Slot Size (SEE DX10 for slot sizes)
- 3/2 (s)** - Depth of Screwdriver Slot

	<b>B</b>	<b>F</b>	<b>FA</b>	<b>R</b>
Model 3	.015	.500	.278	.625
Model 4	.015	.500	.278	.625
Model 75	.015	.438	.278	.500
Model 5	.015	.375	.275	.437
Model 25	.015	.375	.275	.437
Model 6	.015	.250	.188	.312
Model 7	.015	.219	.188	.250
Model 8	.015	NA	NA	.187

**Table 5  
Standard ("Std") Dimensions**

**Round Heads**

	<b>D</b>	<b>FD</b>	<b>J</b>	<b>JL</b>
Model 8	.50	NA	10-32	.50
Model 7	.50	NA	1/4-28	.50
Model 6	.62	.60	5/16-24	.50
Model 25	1.00	.93	7/16-20	.75
Model 5	1.00	.93	7/16-20	.75
Model 75	1.19	1.14	1/2-20	.88
Model 4	1.25	1.15	1/2-20	.88
Model 3	1.25	1.15	1/2-20	.88

**Block Mount Heads**

	<b>D</b>	<b>FD</b>	<b>J</b>	<b>JL</b>
Model 8	.50	NA	10-32	.50
Model 7	1.06	1.01	1/4-28	.75
Model 6	1.12	1.01	5/16-24	.75
Model 25	NA	NA	NA	NA
Model 5	1.50	1.43	7/16-20	1.25
Model 75	NA	NA	NA	NA
Model 4	NA	NA	NA	NA
Model 3	NA	NA	NA	NA

# Air DX Deluxe Rod™ Cylinders Program

<b>Distributor Name:</b>		<b>Contact Person:</b>		<b>PO#</b>		<b>DX05</b>
<b>Customer Name:</b>		<b>Contact Person:</b>		<b>PO#</b>		
<b>Ship To Address:</b>	<b>Requested Ship Date:</b>					
	<b>Model, Type, Stroke, and Options:</b>				<b>Qty:</b>	

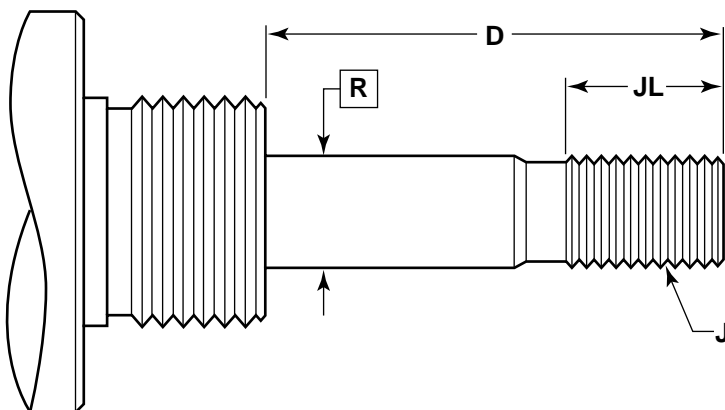

LETTER	SIZE	Ref.
D		1.
J		2.
JL		3.

**Below for Humphrey use only:**

<b>Entered By:</b>	<b>Date:</b>	<b>Order Number:</b>	<b>Tracking #:</b>	<b>Delivery Date:</b>	<b>Price:</b>
--------------------	--------------	----------------------	--------------------	-----------------------	---------------

DX05: Available on all cylinder models (prefix #8 through prefix #3). Metric allowed for "J". All other dimensions in inches.

Purpose: Allows user to specify thread definition and length on a rod of variable length. See Table 4 for boxed dimension definitions.

References

1. D >= 0 and D <= 6.0  
(Rod extension must be greater than or equal to 0.00" and less than or equal to 6.00")
2. J: There are two parts; Size and Threads Per Inch. Choose the thread desired from Table 1. Place the description for the thread size desired in this box. Maximum thread size for your model can be determined by referring to Table.1.

3. JL: Length of the threads  
 $JL \leq 6 \times \text{"J" Size (decimal format)}$  and  
 If U.S. thread:  $JL \leq D - (2.0 \div \text{"J" Pitch})$   
 If Metric thread:  $JL \leq D - (2.0 \times \text{"J" Pitch converted to inches})$

Minimum U.S. External Thread Length =  $3 \div \text{"J" Pitch (Threads Per Inch)}$   
 Minimum Metric External Thread Length =  $3 \times \text{"J" Pitch converted to inches}$   
 Example: Desired thread is 5/16-18  
 $JL \geq 3 \div 18$  and  
 $JL \leq 6.0 \times 5/16$  and  
 $JL \leq D - (2.0 \div 18.0)$

- (These constraints ensure the following:
- A. Proper pitch can be maintained over the full length of thread.
  - B. Thread length will not enter the nose/bearing of front head.
  - C. Thread length will leave room for proper turn diameter including chamfer.)

# Air DX Deluxe Rod™ Cylinders Program

**Table 1**  
**External Threads**  
(Thread sizes available on DX options)

	<b>English</b> (Class 2 Fit)	<b>Metric</b> (H6 Fit)					
Model 4 & 3	Model 75	Model 25 & 5	Model 6	Model 7	Model 8	#8-32 UNC	M3 x .50
						#8-36 UNF	M4 x .7
						#10-24 UNC	M5 x .80
						#10-32 UNF	M6 x 1.00
						1/4-20 UNC	M8 x 1.25
						1/4-28 UNF	M8 x 1.00
						5/16-18 UNC	M10 x 1.50
						5/16-24 UNF	M10 x 1.25
						3/8-16 UNC	M12 x 1.75
						3/8-24 UNF	M12 x 1.50
Model 4 & 3	Model 75	Model 25 & 5	Model 6	Model 7	Model 8	7/16-14 UNC	M14 x 2.00
						7/16-20 UNF	M14 x 1.50
						1/2-13 UNC	M15 x 1.00
						1/2-20 UNF	M16 x 2.00
						9/16-12 UNC	M16 x 1.50
						9/16-18 UNF	
						5/8-11 UNC	
						5/8-18 UNF	

**Table 2**  
**Internal Threads**  
(Internal threads available for the DX options)  
(Internal Metric Threads not Available)  
(Not Available on Models 8 & 7)

<b>English</b> (Class 2 Fit)
#8-32 UNC
#8-36 UNF
#10-24 UNC maximum internal threads
#10-32 UNF Model 6
1/4-20 UNC
1/4-28 UNF Model 5, 25, & 75
5/16-18 UNC
5/16-24 UNF
3/8-16 UNC
3/8-24 UNF Model 3 & 4

**Table 3**  
**Cross-hole Sizes**  
(The size of cross-hole available depends on the model)

	.078"	.141"
Model 3	•	•
Model 4	•	•
Model 75	•	•
Model 5	•	•
Model 25	•	•
Model 6	•	NA
Model 7	•	NA
Model 8	•	NA

• - Hole available  
If hole falls on threaded portion of rod the hole size must be at most 40% of basic thread size.

NA - Hole not available for this model

.078" hole for 1/16" cotter pin  
.141" hole for 1/8" cotter pin

# Air DX Deluxe Rod™ Cylinders Program

**Table 4  
Boxed Dimensions**

(Definitions of the boxed dimensions on the order sheets)  
(Boxed dimensions are determined by cylinder model and are not modifiable under this program.)

- B** - Corner Break Size
- F** - Width Across Flats (Wrench size)
- FA** - Flat Length
- R** - Rod Diameter
- S** - Screwdriver Slot Size (SEE DX10 for slot sizes)
- 3/2 (s)** - Depth of Screwdriver Slot

	<b>B</b>	<b>F</b>	<b>FA</b>	<b>R</b>
Model 3	.015	.500	.278	.625
Model 4	.015	.500	.278	.625
Model 75	.015	.438	.278	.500
Model 5	.015	.375	.275	.437
Model 25	.015	.375	.275	.437
Model 6	.015	.250	.188	.312
Model 7	.015	.219	.188	.250
Model 8	.015	NA	NA	.187

**Table 5  
Standard ("Std") Dimensions**

**Round Heads**

	<b>D</b>	<b>FD</b>	<b>J</b>	<b>JL</b>
Model 8	.50	NA	10-32	.50
Model 7	.50	NA	1/4-28	.50
Model 6	.62	.60	5/16-24	.50
Model 25	1.00	.93	7/16-20	.75
Model 5	1.00	.93	7/16-20	.75
Model 75	1.19	1.14	1/2-20	.88
Model 4	1.25	1.15	1/2-20	.88
Model 3	1.25	1.15	1/2-20	.88

**Block Mount Heads**

	<b>D</b>	<b>FD</b>	<b>J</b>	<b>JL</b>
Model 8	.50	NA	10-32	.50
Model 7	1.06	1.01	1/4-28	.75
Model 6	1.12	1.01	5/16-24	.75
Model 25	NA	NA	NA	NA
Model 5	1.50	1.43	7/16-20	1.25
Model 75	NA	NA	NA	NA
Model 4	NA	NA	NA	NA
Model 3	NA	NA	NA	NA

# Air DX Deluxe Rod™ Cylinders Program

Distributor Name:	Contact Person:	PO#	<b>DX04</b>
Customer Name:	Contact Person:	PO#	
Ship To Address:	Requested Ship Date:		
	Model, Type, Stroke, and Options:	Qty:	

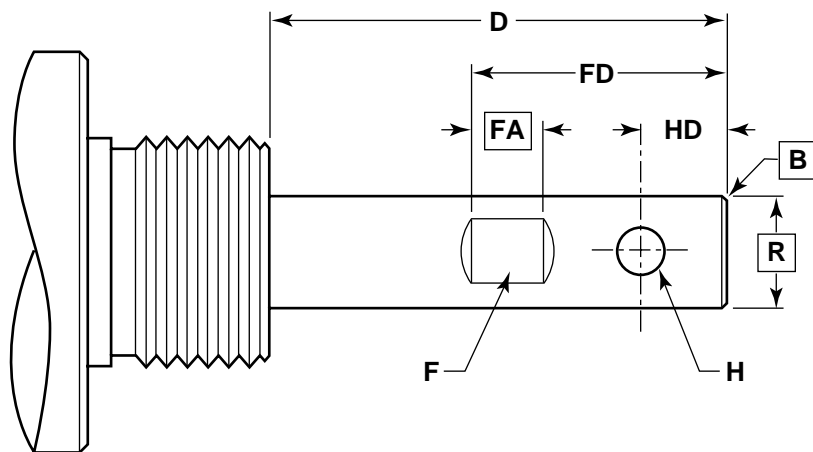

LETTER	SIZE	Ref.
D		1.
FD		2.
HD		3.
H		4.

**Below for Humphrey use only:**

Entered By:	Date:	Order Number:	Tracking #:	Delivery Date:	Price:
-------------	-------	---------------	-------------	----------------	--------

DX04: Not available on Model #8. All dimensions are "D") to be in inches.

Purpose: Allows user to specify the location of a standard wrench flat and a standard cross drilled hole on a plain rod. The user may also specify the length of the rod. The constraints referenced below (Ref. 3) will keep the user from placing the cross hole on the rounds of the wrench flat. The cross drilled hole will be in the same orientation as the wrench flat. The cross drilled hole is intended for use with a cotter pin and not a dowel pin. See Table 4 for boxed dimension definitions.

References

1.  $D \geq 0$  and  $D \leq 6.0$   
(Rod extension must be greater than or equal to 0.00" and less than or equal to 6.00")
2.  $HD \geq (1/2 \times H) + .030$  (minimum wall thickness around hole) and  $HD \leq D - (1/2 \times H)$  (Makes sure hole is within

3.  $FD \leq D$  and (Makes sure wrench flat is within "D")  
 $FD \geq FA$  and (Guarantees user will get all of the wrench flat)  
 $FD \geq FA + .075$  (flat radius) +  $(1/2 \times H) + HD$   
 or (Checks to see hole is on right hand side of flat)  
 $FD \leq HD - (1/2 \times H) - .075$  (flat radius) or  
 (Checks to see if hole is on left hand side of flat)  
 $FD \geq HD + (1/2 \times H)$  and  
 (Checks to see if hole is within bounds of wrench flat but not on flat radii)  
 $FD \leq -HD - (1/2 \times H) + FA$ )

4.  $H = .078$  or  $.141$  depending on model. See Table 3 for hole sizes.  
(Maximum hole size is dependent on model rod diameters.)

# Air DX Deluxe Rod™ Cylinders Program

**Table 1**  
**External Threads**  
(Thread sizes available on DX options)

	<b>English</b> (Class 2 Fit)	<b>Metric</b> (H6 Fit)					
Model 4 & 3	Model 75	Model 25 & 5	Model 6	Model 7	Model 8	#8-32 UNC	M3 x .50
						#8-36 UNF	M4 x .7
						#10-24 UNC	M5 x .80
						#10-32 UNF	M6 x 1.00
						1/4-20 UNC	M8 x 1.25
						1/4-28 UNF	M8 x 1.00
						5/16-18 UNC	M10 x 1.50
						5/16-24 UNF	M10 x 1.25
						3/8-16 UNC	M12 x 1.75
						3/8-24 UNF	M12 x 1.50
Model 4 & 3	Model 75	Model 25 & 5	Model 6	Model 7	Model 8	7/16-14 UNC	M14 x 2.00
						7/16-20 UNF	M14 x 1.50
						1/2-13 UNC	M15 x 1.00
						1/2-20 UNF	M16 x 2.00
						9/16-12 UNC	M16 x 1.50
						9/16-18 UNF	
						5/8-11 UNC	
						5/8-18 UNF	

**Table 2**  
**Internal Threads**  
(Internal threads available for the DX options)  
(Internal Metric Threads not Available)  
(Not Available on Models 8 & 7)

<b>English</b> (Class 2 Fit)
#8-32 UNC
#8-36 UNF
#10-24 UNC maximum internal threads
#10-32 UNF Model 6
1/4-20 UNC
1/4-28 UNF Model 5, 25, & 75
5/16-18 UNC
5/16-24 UNF
3/8-16 UNC
3/8-24 UNF Model 3 & 4

**Table 3**  
**Cross-hole Sizes**  
(The size of cross-hole available depends on the model)

	.078"	.141"
Model 3	•	•
Model 4	•	•
Model 75	•	•
Model 5	•	•
Model 25	•	•
Model 6	•	NA
Model 7	•	NA
Model 8	•	NA

• - Hole available  
If hole falls on threaded portion of rod the hole size must be at most 40% of basic thread size.

NA - Hole not available for this model

.078" hole for 1/16" cotter pin  
.141" hole for 1/8" cotter pin

# Air DX Deluxe Rod™ Cylinders Program

**Table 4  
Boxed Dimensions**

(Definitions of the boxed dimensions on the order sheets)  
(Boxed dimensions are determined by cylinder model and are not modifiable under this program.)

- B** - Corner Break Size
- F** - Width Across Flats (Wrench size)
- FA** - Flat Length
- R** - Rod Diameter
- S** - Screwdriver Slot Size (SEE DX10 for slot sizes)
- 3/2 (s)** - Depth of Screwdriver Slot

	<b>B</b>	<b>F</b>	<b>FA</b>	<b>R</b>
Model 3	.015	.500	.278	.625
Model 4	.015	.500	.278	.625
Model 75	.015	.438	.278	.500
Model 5	.015	.375	.275	.437
Model 25	.015	.375	.275	.437
Model 6	.015	.250	.188	.312
Model 7	.015	.219	.188	.250
Model 8	.015	NA	NA	.187

**Table 5  
Standard ("Std") Dimensions**

**Round Heads**

	<b>D</b>	<b>FD</b>	<b>J</b>	<b>JL</b>
Model 8	.50	NA	10-32	.50
Model 7	.50	NA	1/4-28	.50
Model 6	.62	.60	5/16-24	.50
Model 25	1.00	.93	7/16-20	.75
Model 5	1.00	.93	7/16-20	.75
Model 75	1.19	1.14	1/2-20	.88
Model 4	1.25	1.15	1/2-20	.88
Model 3	1.25	1.15	1/2-20	.88

**Block Mount Heads**

	<b>D</b>	<b>FD</b>	<b>J</b>	<b>JL</b>
Model 8	.50	NA	10-32	.50
Model 7	1.06	1.01	1/4-28	.75
Model 6	1.12	1.01	5/16-24	.75
Model 25	NA	NA	NA	NA
Model 5	1.50	1.43	7/16-20	1.25
Model 75	NA	NA	NA	NA
Model 4	NA	NA	NA	NA
Model 3	NA	NA	NA	NA

# Air DX Deluxe Rod™ Cylinders Program

<b>Distributor Name:</b>		<b>Contact Person:</b>		<b>PO#</b>		<b>DX03</b>
<b>Customer Name:</b>		<b>Contact Person:</b>		<b>PO#</b>		
<b>Ship To Address:</b>	<b>Requested Ship Date:</b>					
	<b>Model, Type, Stroke, and Options:</b>				<b>Qty:</b>	

LETTER	SIZE	Ref.
D		1.
HD		2.
H		3.

**Below for Humphrey use only:**

<b>Entered By:</b>	<b>Date:</b>	<b>Order Number:</b>	<b>Tracking #:</b>	<b>Delivery Date:</b>	<b>Price:</b>
--------------------	--------------	----------------------	--------------------	-----------------------	---------------

DX03: Available on all cylinder models (prefix #8 through prefix #3). All dimensions are to be in inches.

Purpose: Allows user to specify the location of a standard cross hole drilled onto a rod of variable length. The cross drilled hole is intended for use with a cotter pin and not a dowel pin. See Table 4 for boxed dimension definitions.

References

1.  $D \geq 0$  and  $D \leq 6.0$   
(Rod extension must be greater than or equal to 0.00" and less than or equal to 6.00")
2.  $HD \geq (1/2 \times H) + .030$  (Minimum wall thickness around hole) and  $HD \leq D - (1/2 \times H)$   
(This constraint ensures that the cross drilled hole will not break out of the rod end or enter the nose and/or rod bearing.)
3.  $H = .078$  or  $.141$  depending on model. See table 3 for hole sizes.  
(Maximum hole size is dependent on model rod diameters.)

# Air DX Deluxe Rod™ Cylinders Program

**Table 1**  
**External Threads**  
(Thread sizes available on DX options)

	<b>English</b> (Class 2 Fit)	<b>Metric</b> (H6 Fit)					
Model 4 & 3	Model 75	Model 25 & 5	Model 6	Model 7	Model 8	#8-32 UNC	M3 x .50
						#8-36 UNF	M4 x .7
						#10-24 UNC	M5 x .80
						#10-32 UNF	M6 x 1.00
						1/4-20 UNC	M8 x 1.25
						1/4-28 UNF	M8 x 1.00
						5/16-18 UNC	M10 x 1.50
						5/16-24 UNF	M10 x 1.25
						3/8-16 UNC	M12 x 1.75
						3/8-24 UNF	M12 x 1.50
Model 4 & 3	Model 75	Model 25 & 5	Model 6	Model 7	Model 8	7/16-14 UNC	M14 x 2.00
						7/16-20 UNF	M14 x 1.50
						1/2-13 UNC	M15 x 1.00
						1/2-20 UNF	M16 x 2.00
						9/16-12 UNC	M16 x 1.50
						9/16-18 UNF	
						5/8-11 UNC	
						5/8-18 UNF	

**Table 2**  
**Internal Threads**  
(Internal threads available for the DX options)  
(Internal Metric Threads not Available)  
(Not Available on Models 8 & 7)

<b>English</b> (Class 2 Fit)
#8-32 UNC
#8-36 UNF
#10-24 UNC maximum internal threads
#10-32 UNF Model 6
1/4-20 UNC
1/4-28 UNF Model 5, 25, & 75
5/16-18 UNC
5/16-24 UNF
3/8-16 UNC
3/8-24 UNF Model 3 & 4

**Table 3**  
**Cross-hole Sizes**  
(The size of cross-hole available depends on the model)

	.078"	.141"
Model 3	•	•
Model 4	•	•
Model 75	•	•
Model 5	•	•
Model 25	•	•
Model 6	•	NA
Model 7	•	NA
Model 8	•	NA

• - Hole available  
If hole falls on threaded portion of rod the hole size must be at most 40% of basic thread size.

NA - Hole not available for this model

.078" hole for 1/16" cotter pin  
.141" hole for 1/8" cotter pin

# Air DX Deluxe Rod™ Cylinders Program

**Table 4  
Boxed Dimensions**

(Definitions of the boxed dimensions on the order sheets)  
(Boxed dimensions are determined by cylinder model and are not modifiable under this program.)

- B** - Corner Break Size
- F** - Width Across Flats (Wrench size)
- FA** - Flat Length
- R** - Rod Diameter
- S** - Screwdriver Slot Size (SEE DX10 for slot sizes)
- 3/2 (s)** - Depth of Screwdriver Slot

	<b>B</b>	<b>F</b>	<b>FA</b>	<b>R</b>
Model 3	.015	.500	.278	.625
Model 4	.015	.500	.278	.625
Model 75	.015	.438	.278	.500
Model 5	.015	.375	.275	.437
Model 25	.015	.375	.275	.437
Model 6	.015	.250	.188	.312
Model 7	.015	.219	.188	.250
Model 8	.015	NA	NA	.187

**Table 5  
Standard ("Std") Dimensions**

**Round Heads**

	<b>D</b>	<b>FD</b>	<b>J</b>	<b>JL</b>
Model 8	.50	NA	10-32	.50
Model 7	.50	NA	1/4-28	.50
Model 6	.62	.60	5/16-24	.50
Model 25	1.00	.93	7/16-20	.75
Model 5	1.00	.93	7/16-20	.75
Model 75	1.19	1.14	1/2-20	.88
Model 4	1.25	1.15	1/2-20	.88
Model 3	1.25	1.15	1/2-20	.88

**Block Mount Heads**

	<b>D</b>	<b>FD</b>	<b>J</b>	<b>JL</b>
Model 8	.50	NA	10-32	.50
Model 7	1.06	1.01	1/4-28	.75
Model 6	1.12	1.01	5/16-24	.75
Model 25	NA	NA	NA	NA
Model 5	1.50	1.43	7/16-20	1.25
Model 75	NA	NA	NA	NA
Model 4	NA	NA	NA	NA
Model 3	NA	NA	NA	NA

# Air DX Deluxe Rod™ Cylinders Program

Distributor Name:	Contact Person:	PO#	<b>DX02</b>
Customer Name:	Contact Person:	PO#	
Ship To Address:	Requested Ship Date:		
	Model, Type, Stroke, and Options:	Qty:	

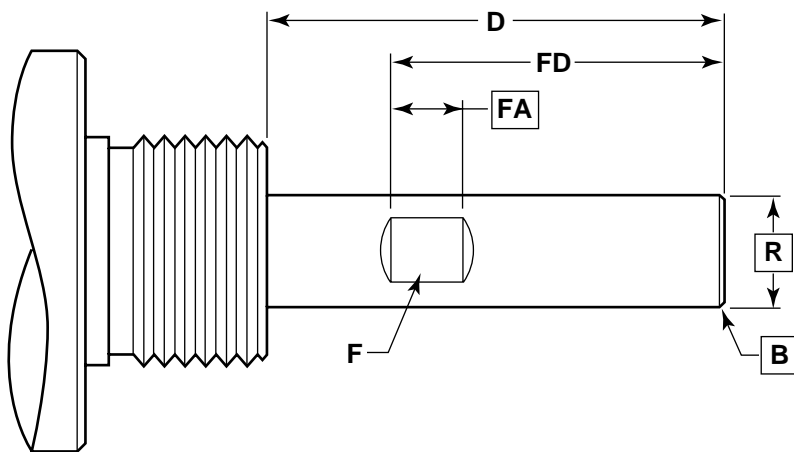

LETTER	SIZE	Ref.
D		1.
FD		2.

**Below for Humphrey use only:**

Entered By:	Date:	Order Number:	Tracking #:	Delivery Date:	Price:
-------------	-------	---------------	-------------	----------------	--------

DX02: Not available on Model 8. All dimensions are to be in inches.

Purpose: Allows user to specify the location of a standard wrench flat on a rod of variable length. See Table 4 for boxed dimension definitions.

References

1.  $D \geq 0$  and  $D \leq 6.0$   
(Rod extension must be greater than or equal to 0.00" and less than or equal to 6.00")
2.  $FD \geq FA$  and  $FD \leq D$   
(This constraint ensures that the whole wrench flat can be machined on the rod, and eliminates the potential for the wrench flat to enter the nose or the rod bearing.)

# Air DX Deluxe Rod™ Cylinders Program

**Table 1**  
**External Threads**  
(Thread sizes available on DX options)

<b>English</b> (Class 2 Fit)		<b>Metric</b> (H6 Fit)					
Model 4 & 3	Model 75	Model 25 & 5	Model 6	Model 7	Model 8	#8-32 UNC	M3 x .50
						#8-36 UNF	M4 x .7
						#10-24 UNC	M5 x .80
						#10-32 UNF	M6 x 1.00
						1/4-20 UNC	M8 x 1.25
						1/4-28 UNF	M8 x 1.00
						5/16-18 UNC	M10 x 1.50
						5/16-24 UNF	M10 x 1.25
						3/8-16 UNC	M12 x 1.75
						3/8-24 UNF	M12 x 1.50
						7/16-14 UNC	M14 x 2.00
						7/16-20 UNF	M14 x 1.50
						1/2-13 UNC	M15 x 1.00
						1/2-20 UNF	M16 x 2.00
						9/16-12 UNC	M16 x 1.50
						9/16-18 UNF	
						5/8-11 UNC	
						5/8-18 UNF	

**Table 2**  
**Internal Threads**  
(Internal threads available for the DX options)  
(Internal Metric Threads not Available)  
(Not Available on Models 8 & 7)

**English**  
(Class 2 Fit)

#8-32 UNC  
#8-36 UNF  
#10-24 UNC maximum internal threads  
#10-32 UNF Model 6  
1/4-20 UNC  
1/4-28 UNF Model 5, 25, & 75  
5/16-18 UNC  
5/16-24 UNF  
3/8-16 UNC  
3/8-24 UNF Model 3 & 4

**Table 3**  
**Cross-hole Sizes**  
(The size of cross-hole available depends on the model)

	.078"	.141"
Model 3	•	•
Model 4	•	•
Model 75	•	•
Model 5	•	•
Model 25	•	•
Model 6	•	NA
Model 7	•	NA
Model 8	•	NA

• - Hole available  
If hole falls on threaded portion of rod the hole size must be at most 40% of basic thread size.

NA - Hole not available for this model

.078" hole for 1/16" cotter pin  
.141" hole for 1/8" cotter pin

# Air DX Deluxe Rod™ Cylinders Program

**Table 4  
Boxed Dimensions**

(Definitions of the boxed dimensions on the order sheets)  
(Boxed dimensions are determined by cylinder model and are not modifiable under this program.)

- B** - Corner Break Size
- F** - Width Across Flats (Wrench size)
- FA** - Flat Length
- R** - Rod Diameter
- S** - Screwdriver Slot Size (SEE DX10 for slot sizes)
- 3/2 (s)** - Depth of Screwdriver Slot

	<b>B</b>	<b>F</b>	<b>FA</b>	<b>R</b>
Model 3	.015	.500	.278	.625
Model 4	.015	.500	.278	.625
Model 75	.015	.438	.278	.500
Model 5	.015	.375	.275	.437
Model 25	.015	.375	.275	.437
Model 6	.015	.250	.188	.312
Model 7	.015	.219	.188	.250
Model 8	.015	NA	NA	.187

**Table 5  
Standard ("Std") Dimensions**

**Round Heads**

	<b>D</b>	<b>FD</b>	<b>J</b>	<b>JL</b>
Model 8	.50	NA	10-32	.50
Model 7	.50	NA	1/4-28	.50
Model 6	.62	.60	5/16-24	.50
Model 25	1.00	.93	7/16-20	.75
Model 5	1.00	.93	7/16-20	.75
Model 75	1.19	1.14	1/2-20	.88
Model 4	1.25	1.15	1/2-20	.88
Model 3	1.25	1.15	1/2-20	.88

**Block Mount Heads**

	<b>D</b>	<b>FD</b>	<b>J</b>	<b>JL</b>
Model 8	.50	NA	10-32	.50
Model 7	1.06	1.01	1/4-28	.75
Model 6	1.12	1.01	5/16-24	.75
Model 25	NA	NA	NA	NA
Model 5	1.50	1.43	7/16-20	1.25
Model 75	NA	NA	NA	NA
Model 4	NA	NA	NA	NA
Model 3	NA	NA	NA	NA

# Air DX Deluxe Rod™ Cylinders Program

<b>Distributor Name:</b>		<b>Contact Person:</b>		<b>PO#</b>		<b>DX01</b>
<b>Customer Name:</b>		<b>Contact Person:</b>		<b>PO#</b>		
<b>Ship To Address:</b>	<b>Requested Ship Date:</b>					
	<b>Model, Type, Stroke, and Options:</b>				<b>Qty:</b>	

LETTER	SIZE	Ref.
D		1.

**Below for Humphrey use only:**

<b>Entered By:</b>	<b>Date:</b>	<b>Order Number:</b>	<b>Tracking #:</b>	<b>Delivery Date:</b>	<b>Price:</b>
--------------------	--------------	----------------------	--------------------	-----------------------	---------------

DX01: Available on all cylinder models. All dimensions are to be in inches.

Purpose: Allows user to specify the length of a plain rod end. See Table 4 for boxed dimension definitions.

References

1.  $D \geq 0$  and  $D \leq 6.0$   
(Rod extension must be greater than or equal to 0.00" and less than or equal to 6.00")

# Air DX Deluxe Rod™ Cylinders Program

**Table 1**  
**External Threads**  
(Thread sizes available on DX options)

	<b>English</b> (Class 2 Fit)	<b>Metric</b> (H6 Fit)					
Model 4 & 3	Model 75	Model 25 & 5	Model 6	Model 7	Model 8	#8-32 UNC	M3 x .50
						#8-36 UNF	M4 x .7
						#10-24 UNC	M5 x .80
						#10-32 UNF	M6 x 1.00
						1/4-20 UNC	M8 x 1.25
						1/4-28 UNF	M8 x 1.00
						5/16-18 UNC	M10 x 1.50
						5/16-24 UNF	M10 x 1.25
						3/8-16 UNC	M12 x 1.75
						3/8-24 UNF	M12 x 1.50
Model 4 & 3	Model 75	Model 25 & 5	Model 6	Model 7	Model 8	7/16-14 UNC	M14 x 2.00
						7/16-20 UNF	M14 x 1.50
						1/2-13 UNC	M15 x 1.00
						1/2-20 UNF	M16 x 2.00
						9/16-12 UNC	M16 x 1.50
						9/16-18 UNF	
						5/8-11 UNC	
						5/8-18 UNF	

**Table 2**  
**Internal Threads**  
(Internal threads available for the DX options)  
(Internal Metric Threads not Available)  
(Not Available on Models 8 & 7)

<b>English</b> (Class 2 Fit)
#8-32 UNC
#8-36 UNF
#10-24 UNC maximum internal threads
#10-32 UNF Model 6
1/4-20 UNC
1/4-28 UNF Model 5, 25, & 75
5/16-18 UNC
5/16-24 UNF
3/8-16 UNC
3/8-24 UNF Model 3 & 4

**Table 3**  
**Cross-hole Sizes**  
(The size of cross-hole available depends on the model)

	.078"	.141"
Model 3	•	•
Model 4	•	•
Model 75	•	•
Model 5	•	•
Model 25	•	•
Model 6	•	NA
Model 7	•	NA
Model 8	•	NA

• - Hole available  
If hole falls on threaded portion of rod the hole size must be at most 40% of basic thread size.

NA - Hole not available for this model

.078" hole for 1/16" cotter pin  
.141" hole for 1/8" cotter pin

# Air DX Deluxe Rod™ Cylinders Program

**Table 4  
Boxed Dimensions**

(Definitions of the boxed dimensions on the order sheets)  
(Boxed dimensions are determined by cylinder model and are not modifiable under this program.)

- B** - Corner Break Size
- F** - Width Across Flats (Wrench size)
- FA** - Flat Length
- R** - Rod Diameter
- S** - Screwdriver Slot Size (SEE DX10 for slot sizes)
- 3/2 (s)** - Depth of Screwdriver Slot

	<b>B</b>	<b>F</b>	<b>FA</b>	<b>R</b>
Model 3	.015	.500	.278	.625
Model 4	.015	.500	.278	.625
Model 75	.015	.438	.278	.500
Model 5	.015	.375	.275	.437
Model 25	.015	.375	.275	.437
Model 6	.015	.250	.188	.312
Model 7	.015	.219	.188	.250
Model 8	.015	NA	NA	.187

**Table 5  
Standard ("Std") Dimensions**

**Round Heads**

	<b>D</b>	<b>FD</b>	<b>J</b>	<b>JL</b>
Model 8	.50	NA	10-32	.50
Model 7	.50	NA	1/4-28	.50
Model 6	.62	.60	5/16-24	.50
Model 25	1.00	.93	7/16-20	.75
Model 5	1.00	.93	7/16-20	.75
Model 75	1.19	1.14	1/2-20	.88
Model 4	1.25	1.15	1/2-20	.88
Model 3	1.25	1.15	1/2-20	.88

**Block Mount Heads**

	<b>D</b>	<b>FD</b>	<b>J</b>	<b>JL</b>
Model 8	.50	NA	10-32	.50
Model 7	1.06	1.01	1/4-28	.75
Model 6	1.12	1.01	5/16-24	.75
Model 25	NA	NA	NA	NA
Model 5	1.50	1.43	7/16-20	1.25
Model 75	NA	NA	NA	NA
Model 4	NA	NA	NA	NA
Model 3	NA	NA	NA	NA