

Warranty, Service & Repair

To register your product with the manufacturer, go to the Flowline website for on-line registration. The website address is as follows:

www.flowline.com

On-line Warranty Registration can be found under Contact Us is the Navigation Bar along the side of the home page.

If for some reason your product must be returned for factory service, contact Flowline Inc. at (562)598-3015 to receive a Material Return Authorization number (MRA), providing the following information:

1. Part Number, Serial Number
2. Name and telephone number of someone who can answer technical questions related to the product and its application.
3. Return Shipping Address
4. Brief Description of the Symptom
5. Brief Description of the Application

Once you have received a Material Return Authorization number, ship the product prepaid in its original packing to:

Flowline Factory Service
MRA _____
10500 Humbolt Street
Los Alamitos, CA 90720

To avoid delays in processing your repair, write the MRA on the shipping label. Please include the information about the malfunction with your product. This information enables our service technicians to process your repair order as quickly as possible.

FLOWLINE®

Switch-Tek Vertical High-Temp Float Level Switch LV30, LV31 and LV32 Series Owner's Manual



Version 1.0A

© 2002 FLOWLINE Inc.

All rights reserved.

Manual # LV900003

7/02

WARRANTY

Flowline warrants to the original purchaser of its products that such products will be free from defects in material and workmanship under normal use and service for a period which is equal to the shorter of one year from the date of purchase of such products or two years from the date of manufacture of such products.

This warranty covers only those components of the products which are non-moving and not subject to normal wear. Moreover, products which are modified or altered, and electrical cables which are cut to length during installation are not covered by this warranty.

Flowline's obligation under this warranty is solely and exclusively limited to the repair or replacement, at Flowline's option, of the products (or components thereof) which Flowline's examination proves to its satisfaction to be defective. FLOWLINE SHALL HAVE NO OBLIGATION FOR CONSEQUENTIAL DAMAGES TO PERSONAL OR REAL PROPERTY, OR FOR INJURY TO ANY PERSON.

This warranty does not apply to products which have been subject to electrical or chemical damage due to improper use, accident, negligence, abuse or misuse. Abuse shall be assumed when indicated by electrical damage to relays, reed switches or other components. The warranty does not apply to products which are damaged during shipment back to Flowline's factory or designated service center or are returned without the original casing on the products. Moreover, this warranty becomes immediately null and void if anyone other than service personnel authorized by Flowline attempts to repair the defective products.

Products which are thought to be defective must be shipped prepaid and insured to Flowline's factory or a designated service center (the identity and address of which will be provided upon request) within 30 days of the discovery of the defect. Such defective products must be accompanied by proof of the date of purchase.

Flowline further reserves the right to unilaterally waive this warranty and to dispose of any product returned to Flowline where:

- a. There is evidence of a potentially hazardous material present with product.
- b. The product has remained unclaimed at Flowline for longer than 30 days after dutifully requesting disposition of the product.

THERE ARE NO WARRANTIES WHICH EXTEND BEYOND THE DESCRIPTION ON THE FACE OF THIS WARRANTY. This warranty and the obligations and liabilities of Flowline under it are exclusive and instead of, and the original purchaser hereby waives, all other remedies, warranties, guarantees or liabilities, express or implied. EXCLUDED FROM THIS WARRANTY IS THE IMPLIED WARRANTY OF FITNESS OF THE PRODUCTS FOR A PARTICULAR PURPOSE OR USE AND THE IMPLIED WARRANTY OF MERCHANTABILITY OF THE PRODUCTS.

This warranty may not be extended, altered or varied except by a written instrument signed by a duly-authorized officer of Flowline, Inc.

SPECIFICATIONS

Step One

Specifications:

Orientation:	± 20° from vertical
Accuracy:	± 3 mm in water
Repeatability:	± 1 mm in water
Specific gravity:	LV30: 0.7 min. LV31: 0.9 min. LV32: 0.8 min.
Contact type:	(1) SPST reed
Contact rating:	240 VAC/VDC @ 20 VA
Contact output:	NO/NC, selectable
Process temp.:	F: -40° to 300° C: -40° to 148.9°
Pressure:	LV30: 100 psi max. (6.9 bar max.) LV31: 275 psi max. (18.9 bar max.) LV32: 750 psi max. (51.7 bar max.)
Sensor rating:	NEMA 6 (IP68)
Sensor material:	316 ss
Process mount:	LV30: 1/8" NPT LV31: 1/8" NPT LV32: 1/4" NPT
Wire type:	LV30: 2-wire, #22 AWG LV31: 2-wire, #22 AWG LV32: 2-wire, #18 AWG
Wire length:	24" (61 cm)
Wire jacket mat.:	Polymeric
Classification:	General purpose
CE compliance:	EN 50082-2 immunity EN 55011 emission EN 61010-1 safety

Part Number Information:

Part #	Material	Thread
LV30-S201	316 ss	1/8" NPT
LV31-S201	316 ss	1/8" NPT
LV32-S201	316 ss	1/4" NPT

Electrical Data:

The reed switches installed within the Switch-Tek level switches are hermetically-sealed, magnetically actuated, make and break type. Switches are SPST and are rated in Volt-Amps (VA). See the chart along side for maximum load characteristics.

Reed Switch Rating		Max. Resistive Load	
VA	Volts	Amps AC	Amps DC
20	0-30	0.4	0.3
	120	0.17	0.13
	240	0.08	0.06

⚠ Warning: ⚠

Contact protection is required for transient or high in-rush current.

Don't be misled by the resistive ratings of the switches. Most applications involve inductive loads.

Don't be misled by the wattage ratings of loads. Low wattage loads are often high inductive devices, making contact protection very important.

LV30-S201 Dimensions:

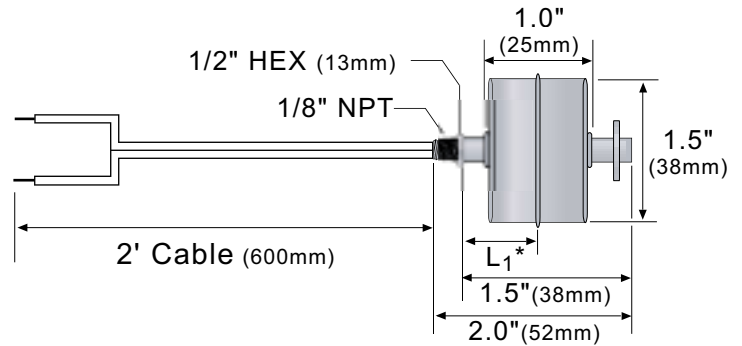

$L_1^* = 0.6"$ (16mm) NO, $.8"$ (19mm) NO, switch actuation level, nominal (based upon specific gravity = 1.0)

LV31-S201 Dimensions:

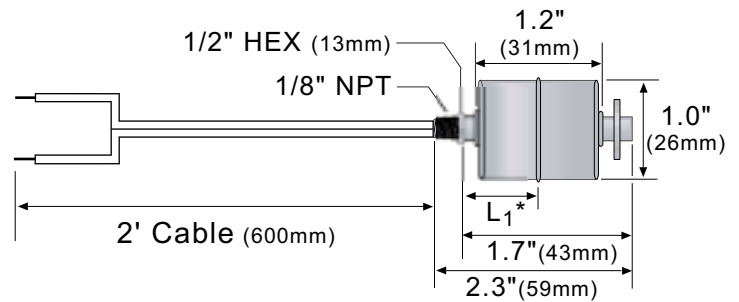

$L_1^* = 0.6"$ (15mm) NO, $.8"$ (21mm) NO, switch actuation level, nominal (based upon specific gravity = 1.0)

LV32-S201 Dimensions:

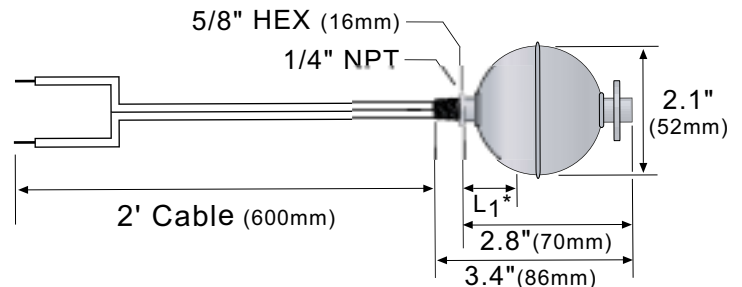

$L_1^* = 1.1"$ (28mm) NO, dimension varies for NC switch actuation level, nominal (based upon specific gravity = 1.0)

SPECIFICATIONS

Step Two

⚠ About This Manual:

PLEASE READ THE ENTIRE INSTRUCTION SHEET PRIOR TO INSTALLING OR USING THIS PRODUCT. This Instruction sheet includes information on all models of Switch-Tek Vertical High-Temp Float Level Switches from Flowline: LV30-S201, LV31-S201 and LV32-S201. Please refer to the part number located on the sensor label to verify the exact model which you have purchased.

⚠ User's Responsibility for Safety:

Flowline manufactures a wide range of liquid level sensors and technologies. While each of these sensors is designed to operate in a wide variety of applications, it is the user's responsibility to select a sensor model that is appropriate for the application, install it properly, perform tests of the installed system, and maintain all components. The failure to do so could result in property damage or serious injury.

⚠ Proper Installation and Handling:

Because this is an electrically operated device, only properly trained staff should install and/or repair this product. Use a proper sealant with all installations. Never overtighten the sensor within the fitting, beyond being hand tight. Always check for leaks prior to system startup.

⚠ Material Compatibility:

All models in the LV30 series are made of 316 stainless steel. Make sure that the model which you have selected is compatible with the application liquids. To determine the chemical compatibility between the sensor and its application liquids, refer to the Compass Corrosion Guide, available from Compass Publications (phone 858-589-9636).

⚠ Wiring and Electrical:

The Switch-Tek Vertical High-Temp Float features a two-wire design with a SPST dry contact closure. Electrical wiring of the sensor should be performed in accordance with all applicable national, state, and local codes.

⚠ Normally Open/Normally Closed:

The orientation position of the float determines whether the switch is Open or Closed. The orientation is identified along the side of the float and can be changed by revering the float 180 degrees.

⚠ Flammable, Explosive and Hazardous Applications:

The LV30 series should not be used within flammable or explosive applications. In hazardous applications, use redundant measurement and control points, each having a different sensing technology. Refer to the National Electric Code (NEC) for all applicable installation requirements in hazardous locations.

⚠ About Single Station Sensing

Flowline's LV30 series use a magnetic float which rides up and down a stem containing the reed switch. The only moving part is the float. No bearings, packing glands, bellows or electronic gadgets are used. The Switch-Tek High-Temp Floats are built rugged to resist shock and vibration. The LV30 series utilize a low cost, flexible design which allows for vertical mounting at the top or bottom of a tank. The Switch-Tek High-Temp Floats can be mounted up, down or up to 20 degrees off vertical.

INSTALLATION

Step Three

Orientation:

A standard NPT female boss in tank top, bottom or side is all that is required. The units operate in any attitude - from the vertical to a 20° inclination - with lead wires up or down. Standard IPS pipe extends level switches to any intermediate level in the tank.

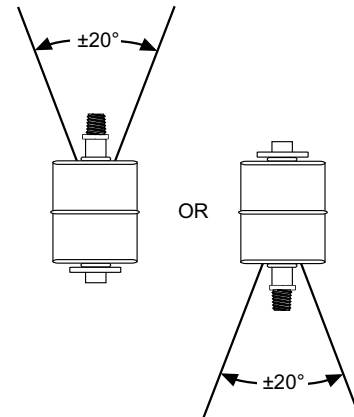

Normally Open or Normally Closed:

Each level switch can be wired Normally Open (NO) or Normally Closed (NC). The Normal Condition is typically when the float rests in a dry state. Each LV30 series level switch is shipped in the NO state and can be switched in the field by rotating the float 180 degrees. The float is marked NO or NC along the side to easily indicate the state of the switch.

Normally Open:

In the NO state, the switch is *open* when the float rests in a dry state along the bottom of the stem and is *closed* when liquid lifts the float.

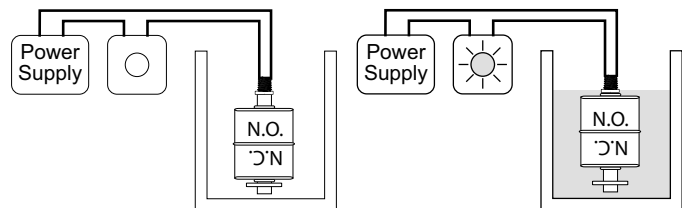

Normally Closed:

In the NC state, the switch is *closed* when the float rests in a dry state along the bottom of the stem and is *open* when liquid lifts the float.

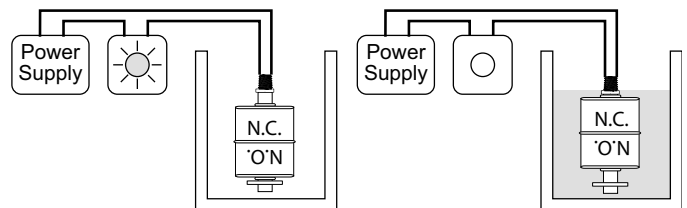

Switching the Output:

To reverse from NO or NC, remove the clip from the stem, rotate the float 180 degrees and replace the clip to the stem.

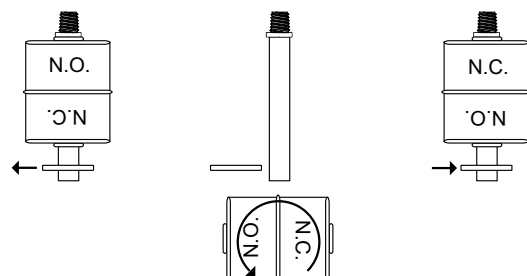

WIRING

Step Four

All Models: Wiring to a Flowline Controller

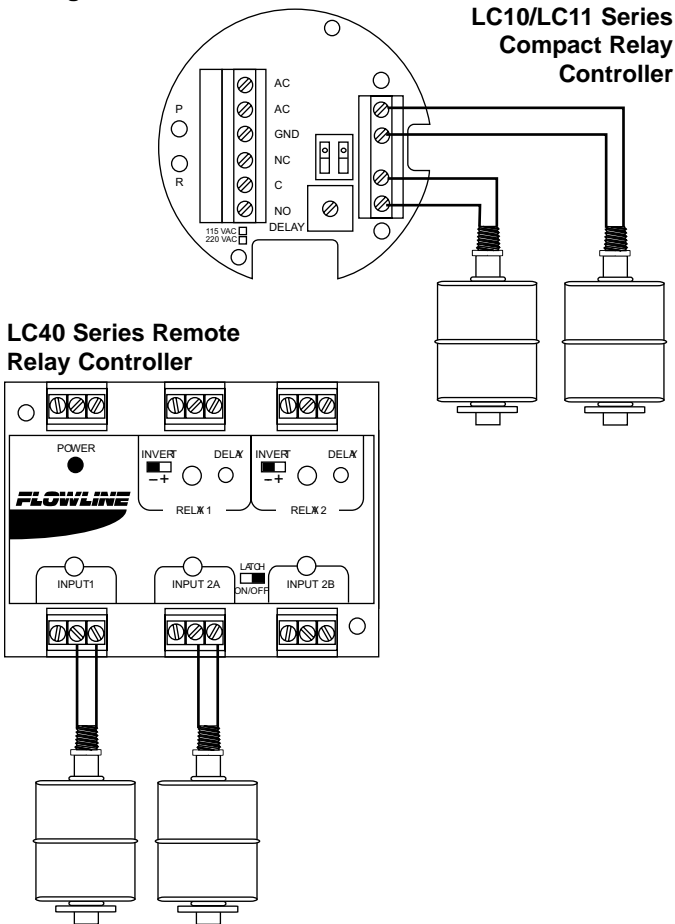

Typical Wiring

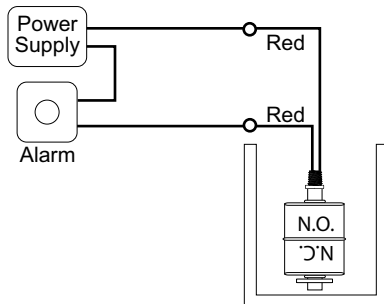

MAINTENANCE

Step Five

General:

The Switch-Tek vertical float has no scheduled maintenance requirement, except to clean off any deposits or scaling from the switch as necessary. The switch may need to be cleaned periodically to prevent jamming or sticking. It is the responsibility of the user to determine the appropriate maintenance schedule, based on the specific characteristics of the application liquid.

Cleaning procedure:

- 1. Power:** Make sure that all power to the switch, controller and/or power supply is completely disconnected.
- 2. Switch removal:** If necessary, make sure that the tank is drained well below the switch prior to removal. Carefully, remove the sensor from the installation.
- 3. Cleaning the switch:** Using a soft bristle brush and mild detergent, carefully wash the switch. Do not use harsh abrasives such as steel wool or sandpaper, which might damage the surface of the sensor. Do not use incompatible solvents which may damage the sensors 316 stainless steel body. Take particular care to remove any scaling from the float body and make sure that it moves freely.
- 4. Sensor installation:** Follow the appropriate steps of installation as outlined in the Installation section of this manual.

Testing the installation:

- 1. Power:** Turn on power to the controller and/or power supply.
- 2. Immersing the switch:** Immerse the float in its application liquid, by filling the tank up to the point of actuation. An alternate method of immersing the switch during preliminary testing is to hold a cup filled with application liquid up to the switch's tip.
- 3. Test:** With the switch being fluctuated between wet and dry states, the switch indicator light in the controller should turn on and off. If the controller doesn't have an input indicator, use a voltmeter or ammeter to ensure that the switch produces the correct signal.
- 4. Point of actuation:** Observe the point at which the rising or falling fluid level causes the switch to change state, and adjust the installation of the switch if necessary.