

Warranty Service and Repair

To register your product with the manufacturer, fill out the enclosed warranty card and return it immediately to:

Flowline Inc.
10500 Humbolt Street
Los Alamitos, CA 90720

If for some reason your product must be returned for factory service, contact Flowline Inc. to receive a Material Return Authorization number first, providing the following information:

1. Part Number, Serial Number
2. Name and telephone number of someone who can answer technical questions related to the product and its application.
3. Return Shipping Address
4. Brief Description of the Symptom
5. Brief Description of the Application

Once you have received a Material Return Authorization number, ship the product prepaid in its original packing to:

Flowline Factory Service
10500 Humbolt Street
Los Alamitos, CA 90720

Please include the information about the malfunction with your product. This information enables our service technicians to process your repair order as quickly as possible.

FLOWLINE®

Compact Relay Controller LC09 Series Owner's Manual



Version 2.0A
©1999 Flowline Inc.
All rights reserved.
Manual #LC900004

WARRANTY

Flowline warrants to the original purchaser of its products that such products will be free from defects in material and workmanship under normal use and service for a period which is equal to the shorter of one year from the date of purchase of such products or two years from the date of manufacture of such products.

This warranty covers only those components of the products which are non-moving and not subject to normal wear. Moreover, products which are modified or altered, and electrical cables which are cut to length during installation are not covered by this warranty.

Flowline's obligation under this warranty is solely and exclusively limited to the repair or replacement, at Flowline's option, of the products (or components thereof) which Flowline's examination proves to its satisfaction to be defective. FLOWLINE SHALL HAVE NO OBLIGATION FOR CONSEQUENTIAL DAMAGES TO PERSONAL OR REAL PROPERTY, OR FOR INJURY TO ANY PERSON.

This warranty does not apply to products which have been subject to electrical or chemical damage due to improper use, accident, negligence, abuse or misuse. Abuse shall be assumed when indicated by electrical damage to relays, reed switches or other components. The warranty does not apply to products which are damaged during shipment back to Flowline's factory or designated service center or are returned without the original casing on the products. Moreover, this warranty becomes immediately null and void if anyone other than service personnel authorized by Flowline attempts to repair the defective products.

Products which are thought to be defective must be shipped prepaid and insured to Flowline's factory or a designated service center (the identity and address of which will be provided upon request) within 30 days of the discovery of the defect. Such defective products must be accompanied by proof of the date of purchase.

THERE ARE NO WARRANTIES WHICH EXTEND BEYOND THE DESCRIPTION ON THE FACE OF THIS WARRANTY. This warranty and the obligations and liabilities of Flowline under it are exclusive and instead of, and the original purchaser hereby waives, all other remedies, warranties, guarantees or liabilities, express or implied. EXCLUDED FROM THIS WARRANTY IS THE IMPLIED WARRANTY OF FITNESS OF THE PRODUCTS FOR A PARTICULAR PURPOSE OR USE AND THE IMPLIED WARRANTY OF MERCHANT ABILITY OF THE PRODUCTS.

This warranty may not be extended, altered or varied except by a written instrument signed by a duly-authorized officer of Flowline, Inc.

If FLOWLINE level transmitters or switches are used for process control where failure of the transmitter or switch could result in personal injury or property damage, an independent means such as a redundant FLOWLINE point level switch should be used. Where FLOWLINE level transmitters or switches are used as a part of a pressure vessel or pipe, care should be taken to independently protect against personal injury or property damage should the FLOWLINE sensor fail or be mishandled. Contact FLOWLINE or your local distributor for additional information.

SPECIFICATIONS

Step One

Supply voltage: 14 - 34 VDC
 Consumption: 120 mA maximum
 Sensor inputs: (1) Sensor
 Sensor supply: 13.5 VDC @ 100 mA
 Configuration: High or low alarm
 Relay type: (1) SPDT
 Relay load: 250 VAC, 6A, 1/4 hp.
 Relay mode: Selectable NO or NC
 Time delay: 0 - 60 seconds
 LED indication: Sensor, relay & power status
 Fail safety: Power fail-safe
 Temperature range: F: -40° to 158°
 C: -40° to 70°
 Enclosure rating: NEMA 4X (IP65)
 Enclosure material: Polypropylene, U.L. 94 VO
 Enclosure rotation: 300° swivel base

Conduit connection: 1/2" NPT (1/2" BSP)
 CE compliance: EN 50082-2 immunity
 EN 55011 emission
 EN 61010-1 low voltage

Flash Alarm (Included with LC09-1002)

Flash type: Xenon tube
 Flash frequency: 1 per second
 Strobe life: 10M cycles
 Supply voltage: 12 - 36 VDC
 Consumption: 80 mA
 Material: Polycarbonate
 Enclosure rating: NEMA 4X (IP65)
 Color: Amber

**Dimensions:
LC09-1004**

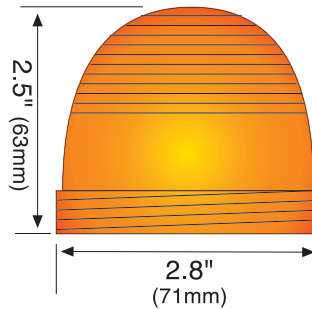

**Dimensions:
LC09-1001**

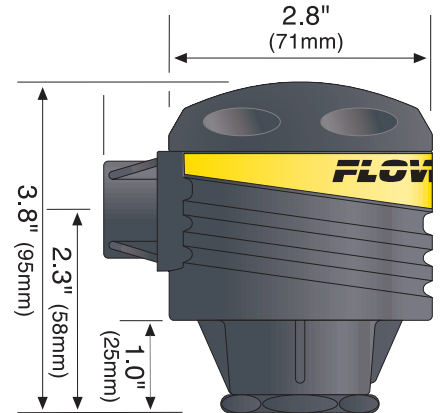

**Dimensions:
LC09-1002**

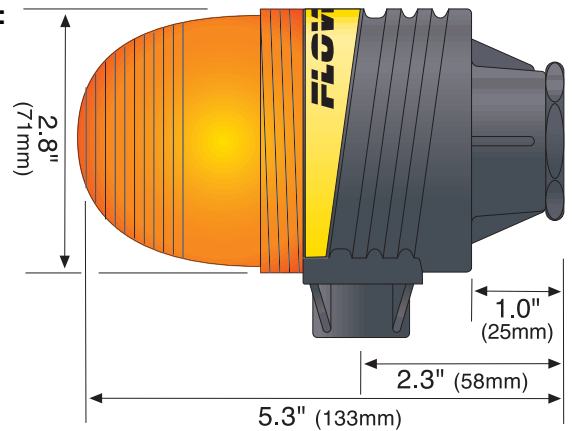

Internal Circuit

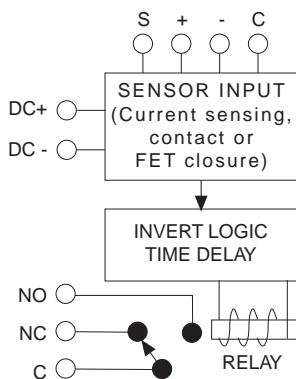

Circuit Board

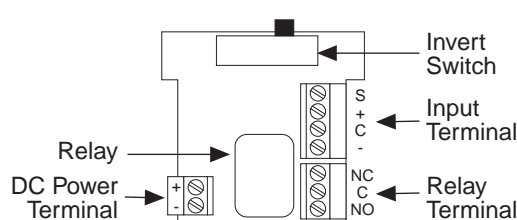

Faceplate Cover

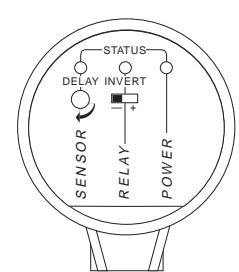

Part Number Information:

| Part # | Thread | Description |
|-----------|----------|---------------------------------------|
| LC09-1002 | 3/4" NPT | DC Relay Controller with Strobe Alert |
| LC09-1052 | 3/4" BSP | DC Relay Controller with Strobe Alert |
| LC09-1001 | 3/4" NPT | DC Relay Controller |
| LC09-1051 | 3/4" BSP | DC Relay Controller |

SAFETY PRECAUTIONS

Step Two

About This Manual:

PLEASE READ THE ENTIRE MANUAL PRIOR TO INSTALLING OR USING THIS PRODUCT. This manual includes information on two different models of Compact Relay Controllers from Flowline: LC09-10_1 and LC09-10_2. The LC09-10_1 is a single-input controller and the LC09-10_2 is a single-input controller with a Strobe Alert™. Many aspects of installation and use are similar between the two models.

User's Responsibility for Safety:

Flowline manufactures several models of controller, with different mounting and switching configurations. It is the user's responsibility to select a controller model that is appropriate for the application, install it properly, perform tests of the installed system, and maintain all components.

Electrical Shock Hazard:

When the cap of the controller is removed, it is possible to contact components that carry high voltage, causing serious injury or death. **All power to the controller and the relay circuit it controls should be turned OFF prior to working on the controller. If it is necessary to make adjustments during powered operation, use extreme caution and use only insulated tools. Making adjustments to powered controllers is not recommended.**

Flammable or Explosive Applications:

Sensor mount controllers should not be used with explosive or flammable liquids, which require an intrinsically safe rating such as the Flowline LC90 series. If you are unsure of the suitability of a controller for your installation, consult your Flowline representative for further information.

Install In a Dry Location:

The LC09 series controller housing is liquid-resistant and made of Polypropylene (PP). When installed properly, the controller is not designed to be immersed. It should be mounted in such a way that it does not normally come into contact with fluid. Refer to an industry reference to ensure that compounds that may splash onto the controller housing will not damage it. Such damage is not covered by the warranty.

Relay Contact Rating:

The relay is rated for a 6 amp resistive load. Many loads (such as a motor during start-up or incandescent lights) are reactive and have an inrush current characteristic that may be 10 to 20 times their steady-state load rating. The use of a contact protection circuit or a

INTRODUCTION

Step Three

Make a Fail-Safe System:

Design a fail-safe system that accommodates the possibility of relay or power failure. If power is cut off to the controller, it will de-energize the relay. Make sure that the de-energized state of the relay is the safe state in your process. For example, if controller power is lost, a pump filling a tank will turn off if it is connected to the Normally Open side of the relay.

While the internal relay is reliable, over the course of time relay failure is possible in two modes: under a heavy load the contacts may be "welded" or stuck into the energized position, or corrosion may build up on a contact so that it will not complete the circuit when it should. In critical applications, redundant backup systems and alarms must be used in addition to the primary system. Such backup systems should use different sensor technologies where possible.

While this manual offers some examples and suggestions to help explain the operation of Flowline products, such examples are for information only and are not intended as a complete guide to installing any specific system.

Sensor-mount controllers

The LC09 is a cost-effective, modular liquid level controller whose body incorporates a female 3/4" NPT (3/4" BSP) fitting, allowing it to be mounted directly onto any Flowline sensor or Switch Pak™ or any 3/4" connection. Simply provide DC power and a controlled device such as a valve, pump, or alarm that can be switched by the controller's relay in response to the sensor input.

Sensor-mount controllers are particularly appropriate for simple processes such as high or low alarms. They can also be a useful part of more complicated systems, providing a fail-safe backup in case a centralized system fails.

Features of the LC09 Single Input Controller

The LC09 Controller is designed to receive a signal from a single liquid sensor. It turns its internal relay On or Off (as set by the invert switch) in response to the presence of liquid, and changes the relay status back again when the sensor is dry. The LC09 may be used with almost any kind of sensor signal: current sensing, contact closure, or FET switch. The relay is a single pole, double throw type; the controlled device can be connected to either the normally open or normally closed side of the relay. A time delay from 0 to 60 seconds can be set before the relay responds to the sensor input. The LC09 is powered from an external 14 to 36 volt DC source.

Typical applications for the LC09 are high level or low level switch/ alarm operations (opening a drain valve whenever liquid level rises to a sensor point) and leak detection (sounding an alarm when a leak is detected, etc.)

GUIDE TO CONTROLS

Step Four

WARNING: Hazardous voltages may be present when the lid of the controller housing and the faceplate are removed, and the terminals are visible. **Turn off all power to the controller and controlled device before opening the housing.**

Power indicator: Green LED lights when DC power is ON.

Relay indicator: Red LED will light whenever the relay is energized.

DC Power terminals: Connect 14 to 36 VDC power to these terminals, insure proper polarity.

Relay terminals (NC, C, NO): Connect the device you wish to control (pump, alarm etc.) to these terminals. The switched device should be a noninductive load of not more than 6 amps; for reactive loads the current must be derated or protection circuits used.

Invert switch: This switch reverses the logic of the relay control in response to the sensor in a powered up state: conditions that used to energize the relay will make it turn off and vice versa. INVERT is ON (+), and OFF (-). When INVERT is OFF the relay is energized when the INPUT LED is on (typically, when the sensor is wet). When INVERT is ON the relay is energized when the sensor INPUT LED is off (dry).

Time Delay: After the input changes state, this control sets a delay from 0 to 60 seconds before the relay will respond. This keeps the controller from responding to temporary conditions (splashing, foaming etc.), or allows time for other processes to take place before the relay opens or closes. Use a small insulated screwdriver to make the adjustment. Turn full counterclockwise for no delay and full clockwise for maximum delay.

Sensor indicator: This yellow LED will light immediately whenever the sensor attached to the sensor input terminals detects liquid, and will turn off when it is dry.

Input terminals: (+) is a 13 VDC power supply (to be connected to the red wire of a Flowline powered sensor), and (-) is the return path from the sensor (to be connected to the black wire of a Flowline powered sensor). These two terminals measure the current used by a powered sensor to determine the wet or dry status. The (S, switch) terminal is used only when connecting to the switched lead of a dry contact closure switch (such as the Flowline reed buoyancy sensors) or a non-Flowline FET switch. The (C, common) terminal is used as the return power path for non-Flowline powered sensors.

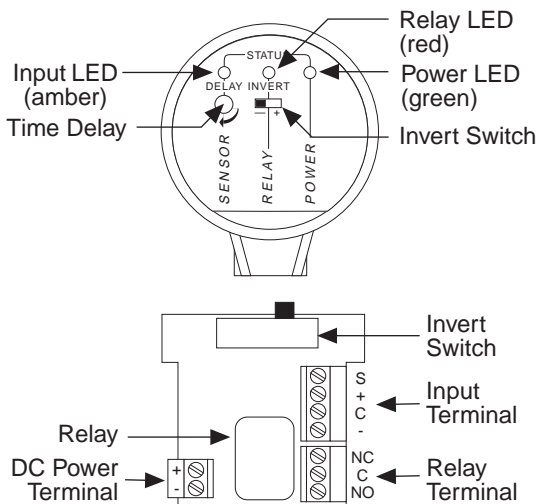

INSTALLATION

Step Five

3/4" NPT Mounting Thread

Installation of the compact relay controller takes advantage of the 3/4" NPT thread located on its base. This makes the controller fully compatible with any of Flowline's level switches or Smart Trak™ or Switch Pak™ mounting systems.

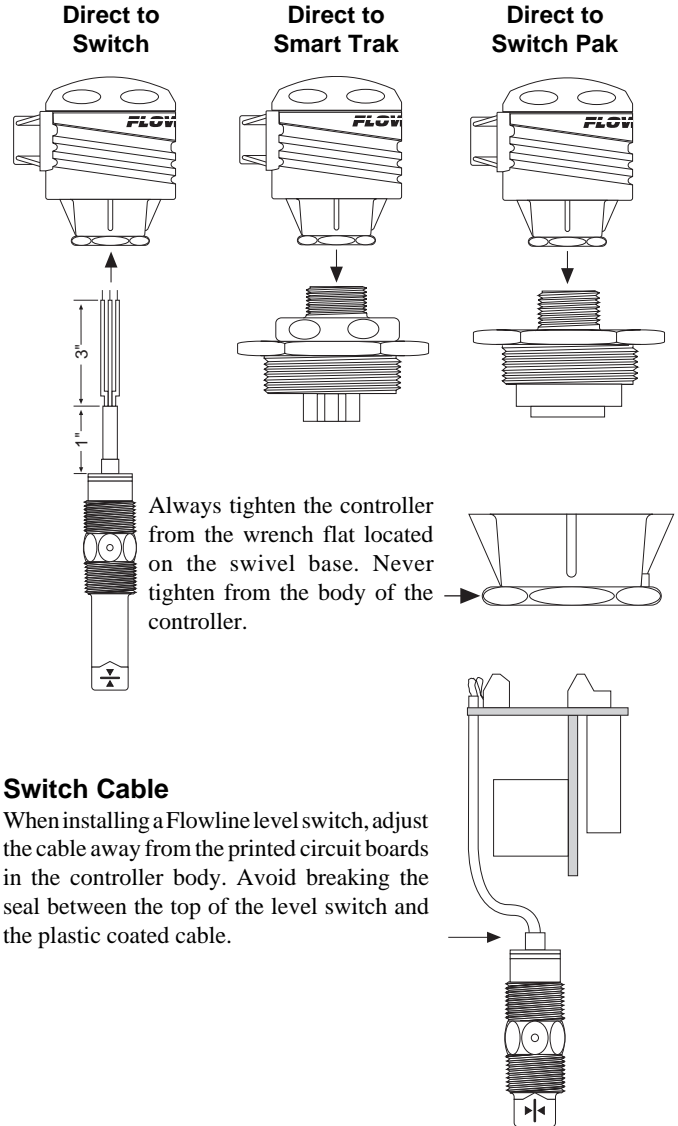

WIRING - SWITCHES

Step Six

Switch Wiring for LC09 Flowline Powered Level Switch

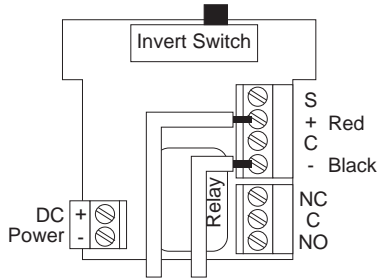

Models:

LZ10-14_2, LZ10-14_3, LZ10-14_5,
LU10-__2, LU10-__3, LU10-__5,
LP50-6002, LP50-6003, LP50-6005,
LP15-14_2, LP15-14_3, LP15-14_5,
LP10-__2, LP10-__3, LP10-__5,
LO10-__2, LO10-__3, LO10-__5

Flowline Reed Switch

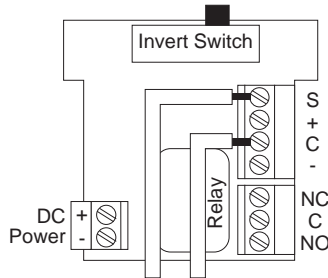

Models:

LV10-__3_1, LV10-__2_1, LV20-__2_1,
LH10-13_1, LH21-1201, LH22-1201

Flowline Flow Switch (FET)

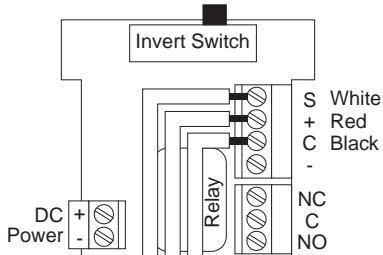

Models:

FT10-__2, FT10-__3, GT10-__2, GT10-__3

Flowline Flow Switch (Relay)

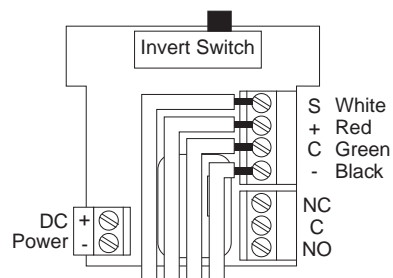

Models:

FT10-__5, GT10-__5

WIRING - OUTPUTS

Step Seven

Strobe Alert Output (Normally Closed)

With the Strobe Alert wired NC, it can be used as a low level alarm (invert off) or as a high level alarm (invert on).

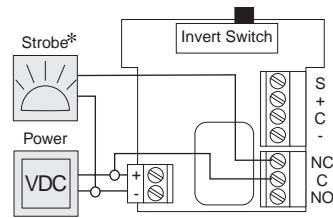

Strobe Alert Output (Normally Open)

With the Strobe Alert wired NO, it can be used as a high level alarm (invert off) or as a low level alarm (invert on).

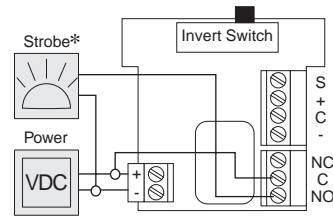

Alarm Output (Normally Open)

With an Alarm wired NC, it can be used as a low level alarm (invert off) or as a high level alarm (invert on).

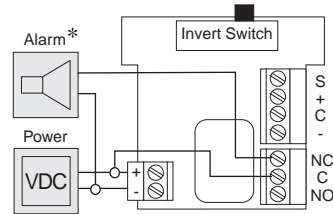

Alarm Output (Normally Open)

With an Alarm wired NO, it can be used as a high level alarm (invert off) or as a low level alarm (invert on).

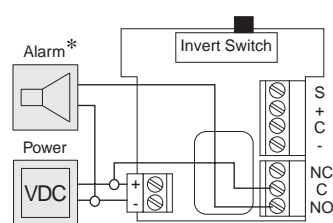

* The alarm/strobe circuit should have a non-interruptible power supply or some other indicator or backup alarm to warn of a power failure in the alarm circuit.

WIRING - OUTPUTS II

Step Eight

About relay loads and protection circuits

The relay in the LC09 is rated for a noninductive load. Other types of load may be connected to the relay if a proper protection circuit is used to minimize arcing and the effects of inrush currents on the relay. This typically involves placing user-provided components (capacitor, resistor, diode, varistor, etc.) across the load or switch. Refer to an industry reference or to the manual of the controlled device for more information about such circuits.

Warning: Any system should be designed by qualified personnel and should include active and passive fail-safe backup systems (such as overflow tubes, etc.) as needed. Any applications that can cause damage to persons or property must use redundant measurement and control points. Secondary systems should use a different sensing technology from the primary system. Such backup systems are not shown in the following examples for clarity.

The relay is a single pole, double throw type. The two terminals NO and NC (normally open and normally closed) will be used in different applications. Remember that the “normal” state is when the relay coil is de-energized and the red relay LED is off. To avoid confusion, we use “energized” and “de-energized” to describe the state of the relay instead of “on” and “off”. This is because the relay may be energized to turn off a device attached to its NC terminal.

Low-Level Alarm The goal is to make sure that the liquid level does not fall below a certain point. If it does, an alarm is supposed to sound, alerting the operator of a low-level condition.

Connecting to the proper relay terminal: If power is accidentally cut to the controller, the sensor’s ability to warn the operator of a low-level condition could be lost. The system must alert the operator not only to low fluid level, but to controller power loss.

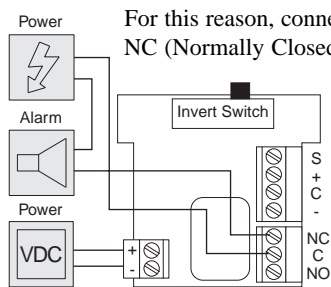

For this reason, connect the hot lead of the alarm to the NC (Normally Closed) side of the relay terminal of the LC09. If power is lost, the relay will be de-energized, and the alarm will sound (if there is still power to the alarm circuit itself). The alarm circuit should have a non-interruptible power supply or some other indicator or backup alarm to warn of a power failure in the alarm circuit.

Setting the INVERT switch: In this application, the normal status of the sensor at the bottom of the tank will be wet, and the relay will be energized holding the alarm circuit open. Both the red relay LED and amber input LED will be on simultaneously, so for this application, INVERT should be set to the OFF position.

High Level Alarm: In the same manner, a sensor and controller can be used to sound an alarm when fluid reaches a high level, with just a change in the location of the sensor and the setting of the INVERT switch.

- The alarm is still connected to the NC side of the relay to allow for a power failure alarm.
- The sensor is normally dry. In this dry condition, we want the relay to be energized so the alarm does not sound: i.e., the red relay LED should be on whenever the amber sensor LED is off. So we turn INVERT ON. If the fluid level rises to the high sensor point, the sensor goes on, the relay de-energizes, and the alarm sounds.

TROUBLESHOOTING

Step Nine

Controller Logic

For all controllers, please use the following guide to understand the operation of the Flowline LC09 controllers.

1. Make sure the Green power LED is On when power is supplied to the controller.
2. The input LED's on the controllers will be Amber when the switch is wet and Off when the switch is dry. If the LED's are not switching the input LED, test the level switch.
3. When the input LED's turn off and on, the relay LED will also switch. With invert Off, the relay LED will be On with the input LED's On and Off with the input LED's Off. With invert On, the relay LED will be Off with the input LED's On and On with the input LED's Off.
4. LC09 model only: When both inputs are wet (amber LED's On), the relay will be energized (red LED On). After that, if one switch becomes dry, the relay will remain energized. Only when both switches are dry (both amber LED's Off) will the controller de-energize the relay. The relay will not energize again until both switches are wet. See the Logic Chart below for further explanation.

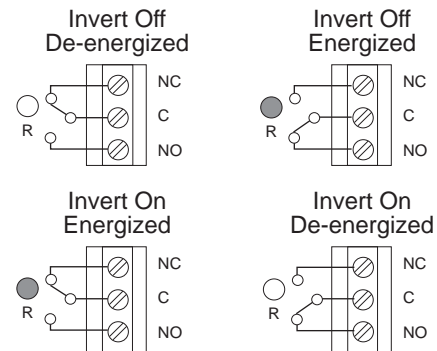

Maintenance

Testing sensor inputs: If the controller is not responding to a sensor, a simple test will allow you to determine whether the sensor or the controller is at fault. Disconnect the sensor from the controller; the INPUT LED should be off. Connect the “+” and “-” sensor terminals with a jumper wire to see if the INPUT LED comes on. If it doesn't, the fault must lie with the controller.