

## Warranty, Service and Repair

To register your product with the manufacturer, fill out the enclosed warranty card and return it immediately to:

FLOWLINE Inc.  
10500 Humbolt Street  
Los Alamitos, CA 90720

If for some reason your product must be returned for factory service, contact your FLOWLINE distributor to receive a material return authorization number first, providing the following information:

1. Part Number, Serial Number
2. Name and telephone number of a person who can answer questions related to the product and its application.
3. Return shipping address
4. Brief description of the symptom
5. Brief description of the application

Once you have received a material return authorization number, ship the product prepaid in its original packing to:

FLOWLINE Factory Service  
10500 Humbolt Street  
Los Alamitos, CA 90720

Please include any related symptom and application information with your product. This information enables our service technicians to process your repair order as quickly as possible.

# FLOWLINE®

## CRICKET™ Alphasonic Level Transmitter Model LA12 Owner's Manual



Version 2.2A  
©1999 FLOWLINE Inc.  
All rights reserved.  
Part # LA900001 4/99

## WARRANTY

FLOWLINE warrants to the original purchaser of its products that such products will be free from defects in material and workmanship under normal use and service for a period which is equal to the shorter of one year from the date of purchase of such products or two years from the date of manufacture of such products.

This warranty covers only those components of the products which are non-moving and not subject to normal wear. Moreover, products which are modified or altered, and electrical cables which are cut to length during installation are not covered by this warranty.

FLOWLINE's obligation under this warranty is solely and exclusively limited to the repair or replacement, at FLOWLINE's option, of the products (or components thereof) which FLOWLINE's examination proves to its satisfaction to be defective. FLOWLINE SHALL HAVE NO OBLIGATION FOR CONSEQUENTIAL DAMAGES TO PERSONAL OR REAL PROPERTY, OR FOR INJURY TO ANY PERSON.

This warranty does not apply to products which have been subject to electrical or chemical damage due to improper use, accident, negligence, abuse or misuse. Abuse shall be assumed when indicated by electrical damage to relays, reed switches or other components. The warranty does not apply to products which are damaged during shipment back to FLOWLINE's factory or designated service center or are returned without the original casing on the products. Moreover, this warranty becomes immediately null and void if anyone other than service personnel authorized by FLOWLINE attempts to repair the defective products.

Products which are thought to be defective must be shipped prepaid and insured to FLOWLINE's factory or a designated service center (the identity and address of which will be provided upon request) within 30 days of the discovery of the defect. Such defective products must be accompanied by proof of the date of purchase.

THERE ARE NO WARRANTIES WHICH EXTEND BEYOND THE DESCRIPTION ON THE FACE OF THIS WARRANTY. This warranty and the obligations and liabilities of FLOWLINE under it are exclusive and instead of, and the original purchaser hereby waives, all other remedies, warranties, guarantees or liabilities, express or implied. EXCLUDED FROM THIS WARRANTY IS THE IMPLIED WARRANTY OF FITNESS OF THE PRODUCTS FOR A PARTICULAR PURPOSE OR USE AND THE IMPLIED WARRANTY OF MERCHANTABILITY OF THE PRODUCTS.

This warranty may not be extended, altered or varied except by a written instrument signed by a duly-authorized officer of FLOWLINE, Inc.

If FLOWLINE level transmitters or switches are used for process control where failure of the transmitter or switch could result in personal injury or property damage, an independent means such as a redundant FLOWLINE point level switch should be used. Where FLOWLINE level transmitters or switches are used as a part of a pressure vessel or pipe, care should be taken to independently protect against personal injury or property damage should the FLOWLINE sensor fail or be mishandled. Contact FLOWLINE or your local distributor for additional information.

## SAFETY PRECAUTIONS

### Step Two

**⚠ About this Manual:** PLEASE READ THE ENTIRE MANUAL PRIOR TO INSTALLING OR USING THIS PRODUCT. This manual includes information on all models of the Cricket™ Alpha-sonic continuous contact level transmitter from FLOWLINE: LA12-0\_1. Please refer to the part number located on the sensor label to verify the exact model which you have purchased.

**⚠ User's Responsibility for Safety:** FLOWLINE manufactures a wide range of liquid level sensors and technologies. While each of these sensors is designed to operate in a wide variety of applications, it is the user's responsibility to select a sensor model that is appropriate for the application, install it properly, perform tests of the installed system, and maintain all components. The failure to do so could result in property damage or serious injury.

**⚠ Proper Installation and Handling:** Because this is an electrically operated device, only properly-trained staff should install and/or repair this product. Use a proper sealant or gasket with all transmitter installations. *Note: Always install the Viton gasket with all versions of the LA12-061. The G threaded version of the Cricket will not seal unless the gasket is installed properly.* Never overtighten the transmitter within the fitting, beyond a maximum of 80 inch-pounds torque. Always check for leaks prior to system start-up.

**⚠ Wiring and Electrical:** A supply voltage of 12-36 VDC is used to power the LA12 transmitter. The sensor systems should never exceed a maximum of 36 volts DC. Electrical wiring of the sensor should be performed in accordance with all applicable national, state, and local codes.

**⚠ Material Compatibility:** The Cricket™ enclosure (LA12 series) is made of Polypropylene (PP) with the diaphragm made of Polyethylene (PE). The pipe adapter is made of Polypropylene (PP). The wave guide can be of either Polypropylene (PP), Polyvinylchloride (PVC) or Polyvinylidene Fluoride (PVDF). Make sure that the wave guide which you have selected is chemically compatible with the application liquids it will contact.

**⚠ Enclosure:** While the transmitter housing is liquid-resistant when installed properly, it is not designed to be immersed. It should be mounted in such a way that the enclosure and sensing diaphragm do not come into contact with fluid.

**⚠ Flammable, Explosive and Hazardous Applications:** The LA12 transmitter systems should not be used within flammable or explosive applications.

**⚠ Make a Fail-Safe System:** Design a fail-safe system that accommodates the possibility of transmitter or power failure. In critical applications, FLOWLINE recommends the use of redundant backup systems and alarms in addition to the primary system.

### ⚠ WARNING ⚠

The Cricket™ is shipped with the pipe adapter installed in the true union fitting. Remove the pipe adapter before installing the pipe.

Avoid installing the Cricket™ near a source of vibrations or loud repetitive noise, such as a motor.

Always install the 1" Viton gasket with all versions of the LA12-061. The G threaded version of the Cricket will not seal unless the gasket is installed properly.

## COMPONENTS

### Step Three

**Input Terminal:** Connect the output device to this terminal. Note the polarity of the terminal. If polarity is not reversed, the transmitter will not operate.

**Power LED:** This Green LED lights when DC power is On.

**Span:** Adjustment for the 4mA setting (invert off) or the 20 mA setting (invert on). Follow instructions in Calibration section, Step 7.

**Invert:** This switch reverses the logic of the 4-20 mA output. With Invert Off, 4 mA setting will be at the end of the wave guide and 20 mA setting will be 2" below the top of the threads. With Invert On, 20 mA setting will be at the end of the wave guide and 4 mA setting will be 2" below the top of the threads.

**1/2" Conduit Connection:** For direct electrical connection.

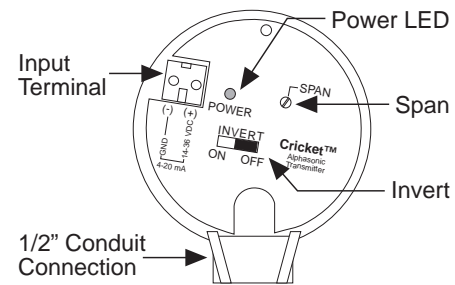

**Cricket Transmitter:** Housing containing the electronics for the transmitter. The housing is rated NEMA 4X (IP 65) with a material of construction of Polypropylene (PP), U.L. 94 VO.

**Diaphragm:** Sensing transducer for transmitting and receiving the sound pulses. The material of construction for the diaphragm is Polyethylene (PE).

**Pipe Adapter:** Attaches the wave guide to the transmitter in conjunction with the true union fitting. Material of construction for the pipe adapter is PP and the female thread is a 1/2" NPT.

**True Union Fitting:** Attaches the wave guide to the transmitter. Also provides the mounting threads for the Cricket™. Threads for the true union fitting are either 1" NPT or 1" G. Material of construction for the true union fitting is Polypropylene (PP).

**Wave Guide:** Device which directs the sound pulses created by the transmitter. Materials of construction for wave guides are Polypropylene (PP), Polyvinylidene Fluoride (PVDF) or Polyvinylchloride (PVC).

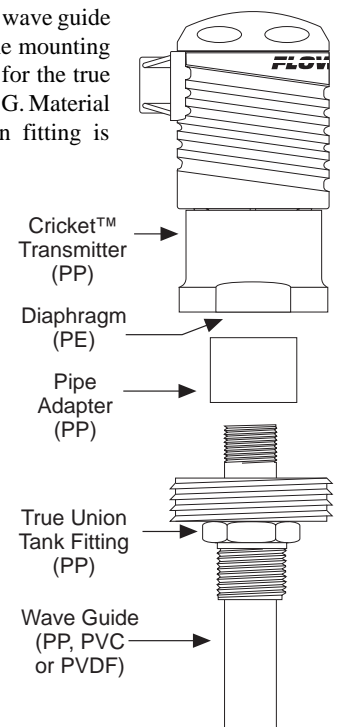

## ASSEMBLY

### Step Four

#### MODEL LA12-\_0\_1-00" ONLY:

Cricket wave guides may be assembled in the factory or in the field. If your Cricket was factory assembled, skip to installation. If your Cricket requires field assembly, then use the following instructions below.

1. First, remove the true union fitting from the transmitter. **The assembly can be removed by hand.**

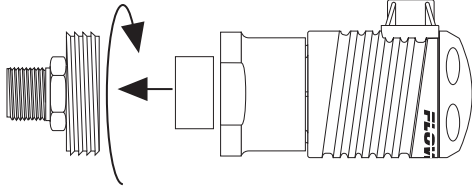

2. Turn a 1/2" NPT male thread on the end of the 1/2" schedule 40 or 80 pipe.
3. Locate the pipe adapter and thread the pipe into the 1/2" NPT thread.

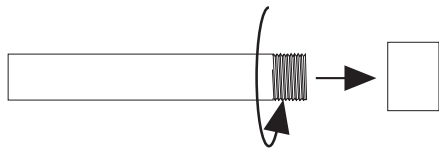

4. Drill a 1/8" pressure equalization hole through the pipe. The location of the hole should be placed from 1" to 1-1/2" from the top of the wave guide.

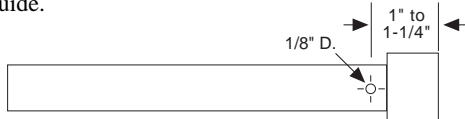

5. Make sure all burrs have been removed from the pipe ID.
6. Insert the wave guide assembly into the true union fitting.

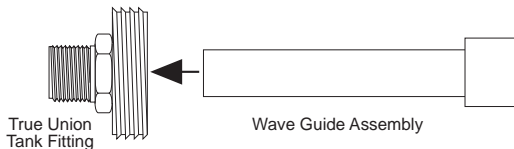

7. Finally, insert the assembled pieces into the transmitter. **Tighten the fitting to hand tight.**
8. Proceed to the calibration section.

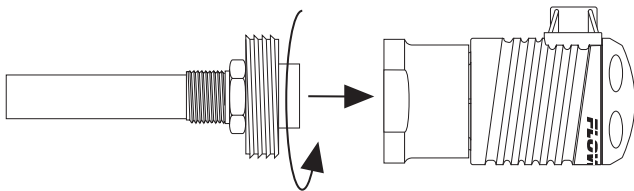

**Always use a 1/2" schedule 40 or 80 (PP, PVDF or PVC) pipe.**

## CALIBRATION

### Step Five

The Cricket™ measurement span may be calibrated over the entire range of the wave guide. Use the following procedure to calibrate the measurement span.

1. Connect a multimeter in series to read current. The top of the Cricket's™ current signal is located 2" from the bottom of the threads. The calibration procedure for the transmitter requires that the bottom of the transmitter's current signal be set using the Span potentiometer.
2. Set Invert switch to OFF.
3. Set level to lowest point. A cup of liquid or a piece of tape over the end of the pipe may be used as a substitution for a low level reading.
4. Turn Span until current reads 4 mA. Turning pot counterclockwise will lower the current and turning the pot clockwise will increase the current. Always increase current to above 5 mA and slowly return to 4 mA for best results. The Cricket™ is now calibrated for normal operation. Remove the cup of water or tape and continue on to Installation (Step Six).

If the Cricket's current signal is need to be reversed (20 mA at the end of the pipe), continue on to step five.

5. Turn Invert to ON if 20 mA signal at end of LA12 is required. Adjust pot until 20 mA is read. Always decrease current to below 19 mA and slowly increase to 20 mA for best results.
6. Remove cup of water or tape if required.

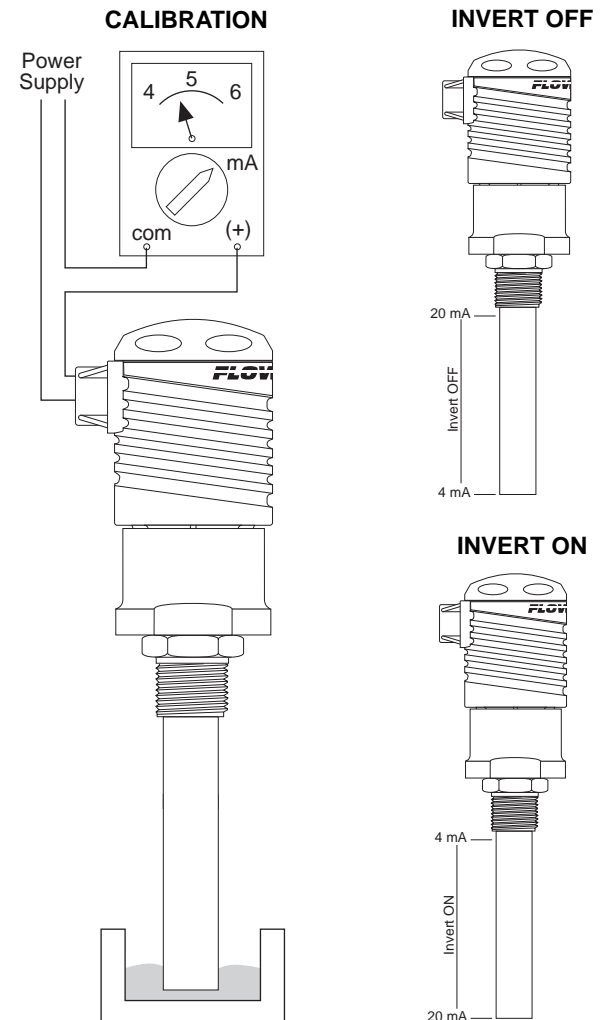

# INSTALLATION

## Step Six

FLOWLINE's LA12 transmitter may be installed through the tank top, through a stand pipe top or to the side of a tank. Tank top and stand pipe installations require a 1" NPT fitting or blind flange. Side wall installations require a side mount bracket from FLOWLINE, model LM50-1001, and a 2" to 1" NPT reducer bushing or equivalent.

1. Install the appropriate 1" fitting in the top wall of the tank or stand pipe. Prior to installation, make sure that the fitting has been installed properly and checked for leaks. Use a proper sealant at the time of installation to ensure a liquid-tight seal. Secondly, make sure that the fitting's threads are not damaged or worn.
2. Unscrew the True Union Tank Fitting from the transmitter. Install True Union Tank Fitting along with the Wave Guide Assembly into the fitting. Apply the appropriate amount of sealant to the tapered threads which will be screwed into the fitting.
3. Insert the Transmitter on the True Union Tank Fitting and **tighten to hand tight**.
4. Always check for leaks prior to system start-up. To ensure proper installation, a complete leak test and simulation of actual process conditions should be performed.

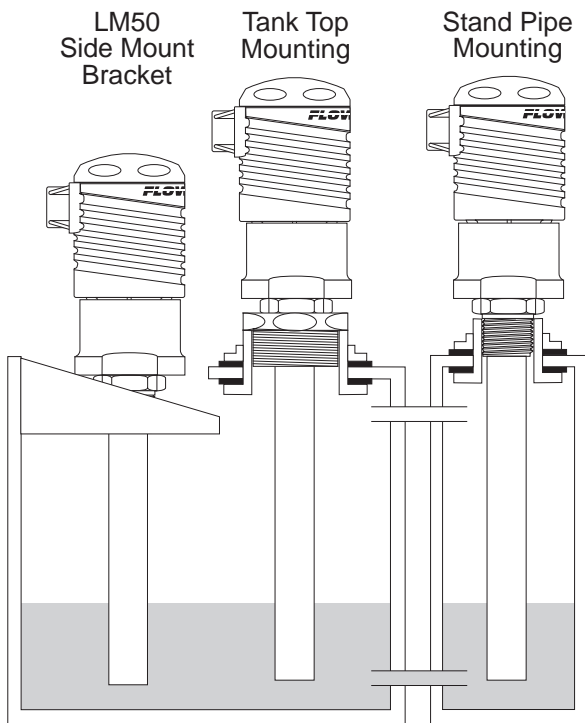

**WARNING**

Avoid installing the Cricket™ near a source of vibrations or loud repetitive noise, such as a motor.

Do not insert or remove the Cricket™ quickly from its fitting. Doing so may increase the back pressure within the pipe and cause the diaphragm to rupture.

Always install the 1" Viton gasket with all versions of the LA12-061. The G threaded version of the Cricket will not seal unless the gasket is installed properly.

# WIRING

## Step Seven

Remove the cap of the LA12 transmitter enclosure. The terminals of the transmitter are visible from the top of the enclosure.

### 1. Wiring to a FLOWLINE Continuous Controller (LC52):

Connect the (+) terminal to the positive 24 VDC, 4 - 20 mA terminal on the LC52 controller. Connect the (-) terminal to the GND terminal on the LC52 continuous controller (See illustration below). Check LC52 instruction manual for setting the LC52 for loop powered operation.

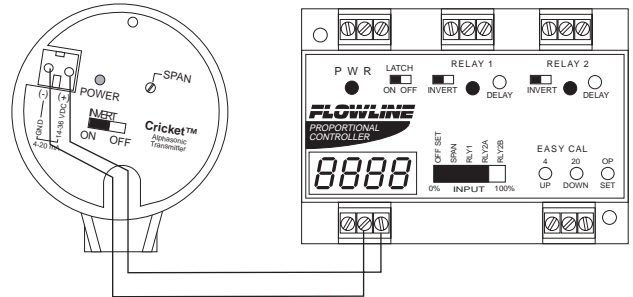

### 2. Wiring to a Two-Wire Loop Indicator:

The LA12 requires a loop indicator that receives a 4-20 mA current input. A 12-36 VDC power supply is required for the system. Connect the (+) terminal of the LA12 transmitter to the positive VDC terminal on the power supply. Connect the (-) terminal on the LA12 to the (+) terminal on the loop indicator. Connect the (-) of the loop indicator to the (-) of the power supply (See illustration below).

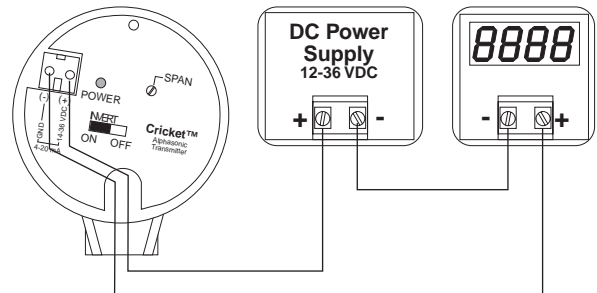

### 3. Wiring to a typical PLC:

The LA12 requires a PLC which provides a 12-36 VDC excitation and receives a 4-20 mA current input. Connect the (+) terminal of the LA12 transmitter to the positive VDC power terminal. Connect the (-) terminal on the LA12 to the (+) channel on the PLC. Connect the (-) of the PLC to the (-) of the power terminal (See illustration below).

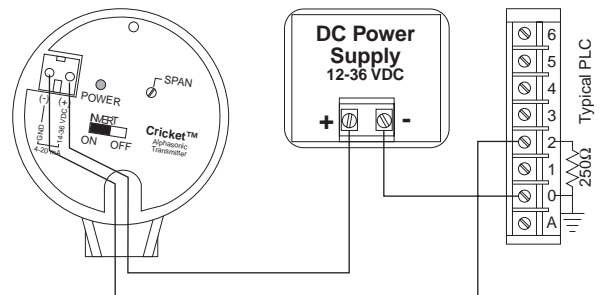

# MAINTENANCE

## Step Eight

### General:

The LA12 series level transmitter itself requires no periodic maintenance except cleaning as required. It is the responsibility of the user to determine the appropriate maintenance schedule, based on the specific characteristics of the application liquids.

### Cleaning Procedure:

1. **Power:** Make Sure that all power to the transmitter, controller and/or power supply is completely disconnected.
2. **Sensor Removal:** In all through-wall installations, make sure that the tank is drained well below the sensor prior to removal. Carefully, remove the sensor from the installation.
3. **Cleaning the Sensor:** Use a soft bristle brush and mild detergent, carefully wash the wave guide of the LA12. Do not use harsh abrasives such as steel wool or sandpaper, which might damage the transmitter's surface. Do not use incompatible solvents which may damage the transmitters PP, PVDF or PVC plastic body.
4. **Sensor Installation:** Follow the appropriate steps of installation as outlined in the installation section of this manual.

# SPECIFICATIONS

## Step One

Range: 0.3 to 10' (9 cm to 3 m)  
 Accuracy:  $\pm 1\%$  of span in air  
 Resolution: 0.125" (3 mm)  
 Frequency: 2 kHz (nominal)  
 Pulse rate: 5 per second  
 Dead band: 0.3' (5 cm) minimum  
 Supply voltage: 12-36 VDC  
 Loop resistance: 600 ohms @ 36 VDC  
 Signal output: 4-20 mA, 12-36 VDC  
 Signal invert: 4-20 mA or 20-4 mA  
 Minimum range: 8"  
 Maximum range: 120"  
 Span adjustment: Potentiometer  
 Indication: LED for power status  
 Temperature rating:  
 F:  $-40^{\circ}$  to  $140^{\circ}$   
 C:  $-40^{\circ}$  to  $60^{\circ}$

Temp. compensation: Automatic over range  
 Pressure rating: Atmospheric  
 Wave guide: Schedule 40 or 80, 1/2"  
 Guide materials: PVC, PP or PVDF  
 Enclosure rating: NEMA 4X / IP65  
 Enclosure material: Polypropylene, U.L. 94 VO  
 Diaphragm material: Polyethylene  
 Mounting threads: 1" NPT (1" G)  
 Mounting gasket: Viton 1" (metric only)  
 Conduit connection: 1/2" NPT  
 Thread material: PP  
 CE compliance: EN 50082-2 immunity  
 EN 55011 emission

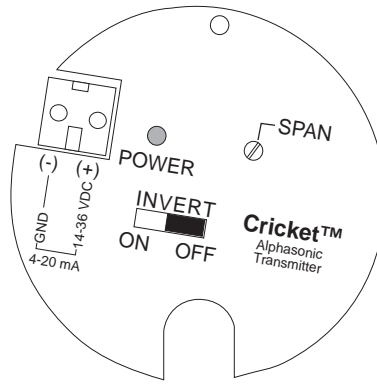

| Alphasonic Transmitter |            |
|------------------------|------------|
| LA12 - 0 1             |            |
| <b>Guide Material</b>  | 1 - PP     |
|                        | 5 - PVDF   |
|                        | 7 - PVC    |
| <b>Mounting Thread</b> | 0 - 1" NPT |
|                        | 2 - 1" G   |

## About Alphasonic Contact Technology:

An Alphasonic sound wave is pulsed five times per second from the base of the transducer. The sound wave travels down the pipe and reflects against the process medium below before returning back to the receiver. The electronics measures the time of flight between the sound generation and receipt, and translates this figure into the distance between the transmitter and process medium below.

