



Contromatics

Metal Seated Quarter Flex
High Temperature Butterfly Valve

ANSI Class 150 and 300



Tri-Seal Valve Company

12495 Airline Highway Suite-C, Baton Rouge, LA 70817

Nationwide: (866) 465-1717 • Local: (225) 755-1717 • Fax (225) 755-1077

www.tri-sealvalve.com



Contromatics Series QF

Metal-Seated Quarter-Flex Butterfly Valves

Sizes

ANSI Class 150
3" - 12"

ANSI Class 300
3" - 12"

Wafer or lug patterns

Specifications

ASME B16.20 API 609 5TH Ed.

ASME B16.34 MSS SP-6

ASME B16.5 MSS SP-25

ASME B31.1

Certified (Optional)

CE Mark

NACE MR0175

General Design Overview

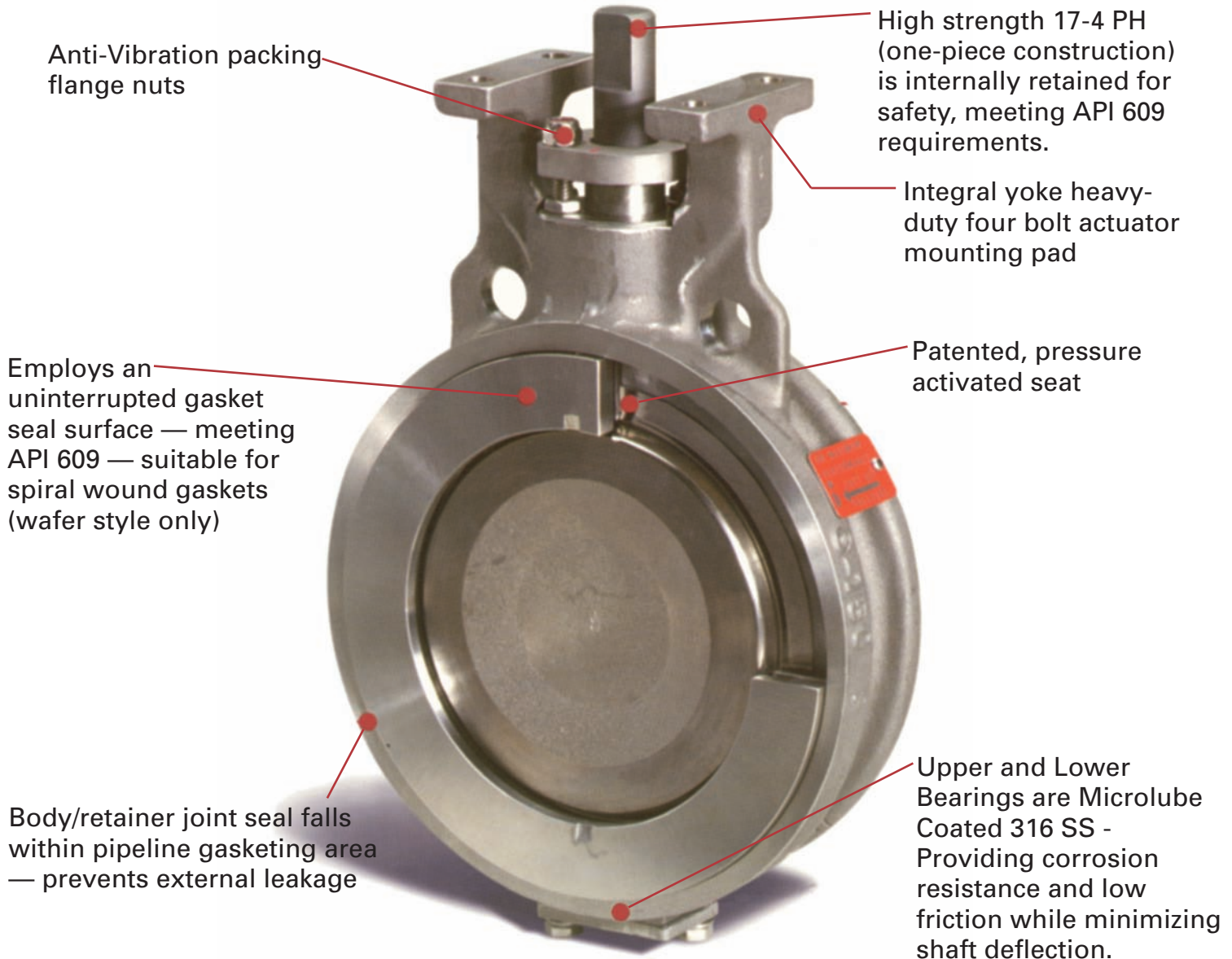

Parts and Features

Contromatics QF Series Metal-Seated

The Metal-Seated Qtr Flex series of valves features advanced metal-seated design butterfly products built for high-temperature service in the utility, chemical processing, petroleum, and marine industries. The Metal-Seated Qtr Flex valve combines the economy and performance of a butterfly valve with a high degree of the application flexibility of a ball valve. In many installations, the Metal-Seated Qtr Flex valve out-performs gate, globe, and plug valves costing hundreds of dollars more. The precision-machined valve is suitable for temperatures up to 750°F, and pressure up to 740 psi. The valves stainless steel seat makes sealing proportionally tighter with increasing line pressure. The pressure-balanced shaft and adjustable packings provide maximum

shaft-sealing efficiency on class 300. This unique combination of design features, long-life materials, and quality construction make the Metal-Seated Qtr Flex valve the lowest-maintenance, most dependable, and best value high-temperature, metal-seated butterfly valve you can buy.

In either carbon steel or stainless steel, the Metal-Seated Qtr Flex metal-seated butterfly valves are now available, wafer or lugged, 3" through 12", in Class 150 and 3" through 12" in Class 300. Larger sizes are available upon application; contact factory for details. For applications that require high-quality butterfly valves that can handle the toughest high-temperature environments, choose the Metal-Seated Qtr Flex valve series.

Patented Pressure Assisted Seat Design

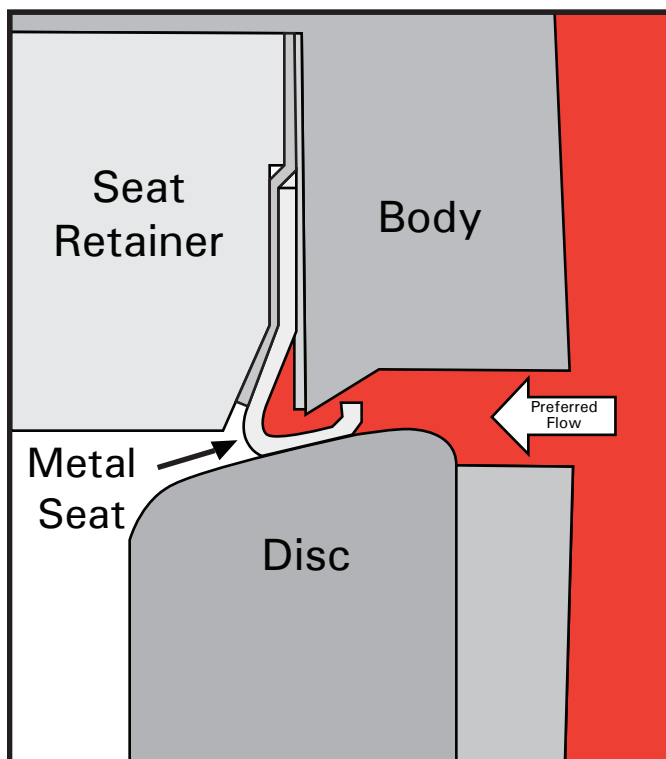

High Performance Seat

The Metal-Seated Qtr Flex valve incorporates an exclusive seating design that ensures tight sealing every time. The stainless steel seat provides excellent performance in a wide range of service conditions. As shown in the diagram, line pressure exerts a force within a specially designed metal-seat cavity that forces the seat against the valve disc. Increased line pressure serves to tighten the seal, ensuring a continuous tight closure.

Parts and Features Overview

Integrally Cast Travel Stop

The internal travel stop is designed to provide proper disc positioning and the prevent seat damage due to the disc rotating beyond the closed position.

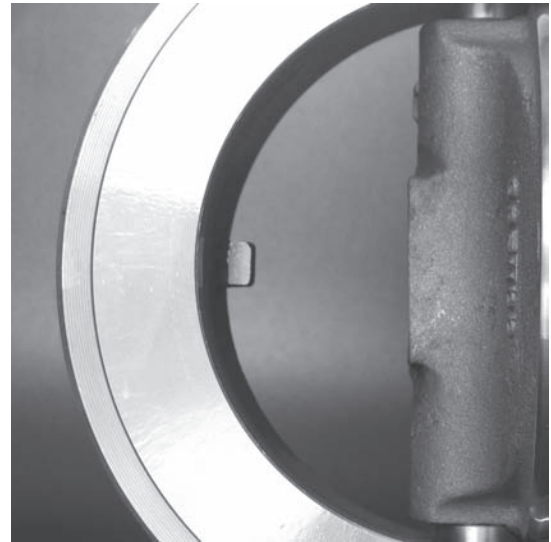

Double Offset Shaft

The double offset shaft design reduces seat wear and enhances sealing by providing a camming action that lifts the disc off the seat. This minimizes seat contact in both directions, resulting in lower operating torques, longer seat life, and prevents the possibility of seat deformation from excessive pressure on the seat. This offset design results in full 360° sealing contact.

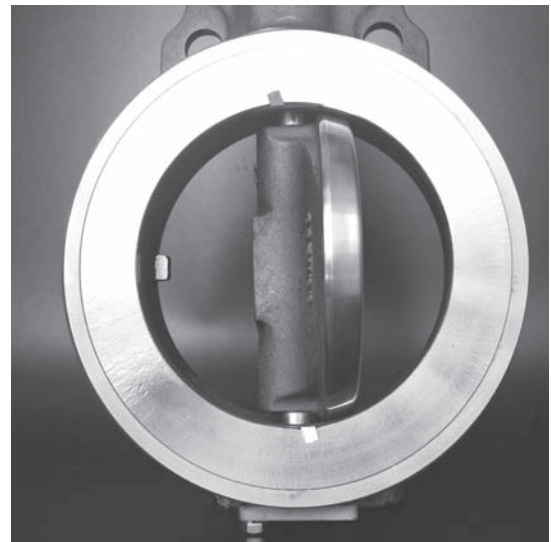

One Piece Shaft

The heavy duty one-piece shaft (in sizes 2½" - 12") constructed of high strength 17-4 PH or 316 Stainless Steel, is internally retained by a snap ring located above the packing area (non-wetted area). This provides safe tamper-proof retention that does not interfere with packing adjustments, eliminating the need for removal of the shaft when replacing packing (meets API 609 standards). And for absolute positive indication of valve position, the shaft is engraved to denote the open and closed positions.



Disc to Shaft Attachment

The shaft is secured to the disc by utilizing a modified Woodruff key design, up through 8", that is tack welded to prevent loosening. Sizes 10" and above use cryogenically shrink fitted stainless steel pins that are prefitted at assembly and expand in ambient temperature for absolute positive retention.

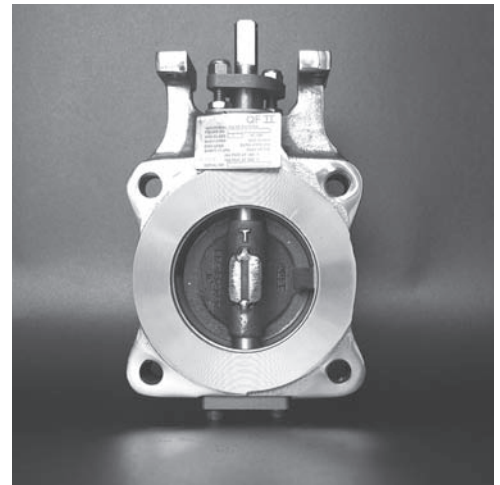

Seat Retainer

The seat retainer in wafer style valves utilize a locking method that precludes the use of set screws, thus providing an uninterrupted gasket (pipeline) surface area, meeting API 609 requirements. The retainer/body joint falls within the gasketing area preventing any external leakage in the event of seat failure. Furthermore, the retainer protects the seat from premature failure due to erosion, and since no special tools are required in the removal of the seat retainer, maintenance is quick and easy.



Special Services Requirements

Live Load Packing

Metal-Seated Qtr-Flex valves are available with inconel discs springs to maintain constant load on the Graphite stem packing.

Use option S1 or consult the How To Order Guide

Steam Service

Metal-Seated Qtr-Flex valves are available for many steam service applications. Ratings listed are for on/off service and depending on shaft material may be de-rated.

Materials of Construction

Materials		Carbon Steel	Stainless Steel
Part	Name	1150 / 1151 / 1300 / 1301	2150 / 2151 / 2300 / 2301
1	Outer Gland Ring	300 Series Stainless Steel	
2	Shaft Ret. Plate	300 Series Stainless Steel	
3	Shaft Ret. Ring	300 Series Stainless Steel	
4	Packing	Graphite	
5	Inner Gland Ring	316 Stainless Steel	
6	Bearing	316 SS Coated	
7	Thrust Washer	316 Stainless Steel	
8	Key/Pin	Key 17.4 / PIN 316 SS	
9	Shaft/Disc Assembly	17.4 Shaft / CF8M Disc Plated	
10	Body	ASTM A216 Grade WCB	ASTM A351 Grade CF8M
12	Seat Retainer	ASTM A515 OR 516 GR 70	ASTM A240 GR 316 SS
13	Seat	304 Stainless Steel Plated	
13A	Seal	Grafoil Gaskets	
14	Retaining Spring	Inconel X750	
16	Stud	18-8 SS	
17	Self Locking Nut	18-8 SS	
18	Gland Retainer	300 Series Stainless Steel	
19	Jam Nut	18-8 SS	
20	End Cap	316 Stainless Steel	
21	Hex Head Cap Screw	18-8 SS	
22	Split Lockwasher	18-8 SS	
23	Name Plate	300 Series Stainless Steel	
24	Sockethead Cap Screw	18-8 SS	
27	End Cap Seal	Grafoil	

Dimensions (inches) - ANSI Class 150

Keyed Stem
10"-24" Cl. 150
8"-12" Cl. 300

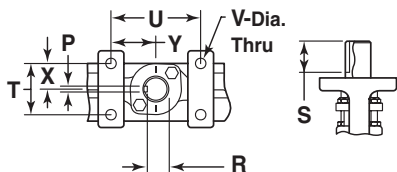

Flatted Stem
2 1/2"-8" Cl. 150
3"-6" Cl. 300

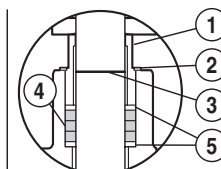
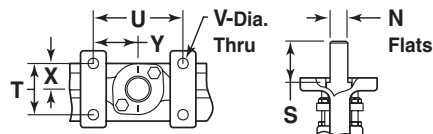

Stem Detail

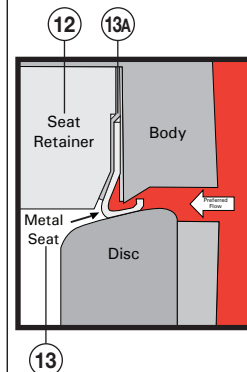
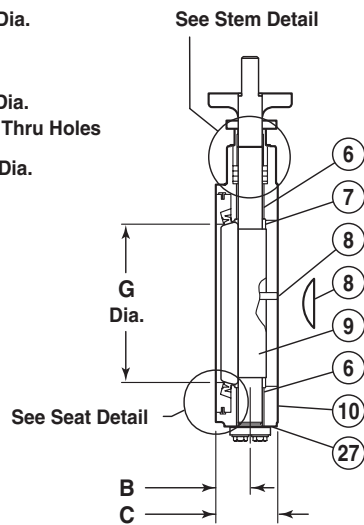
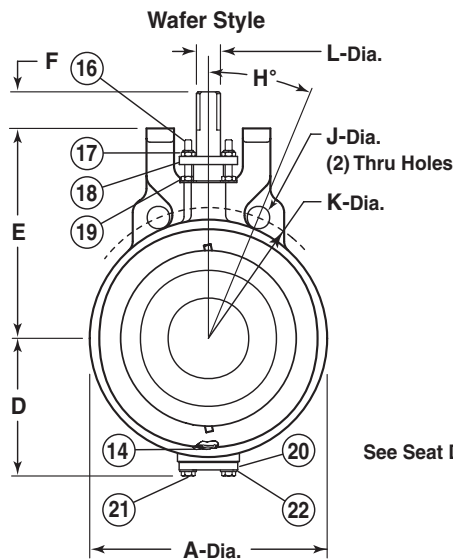
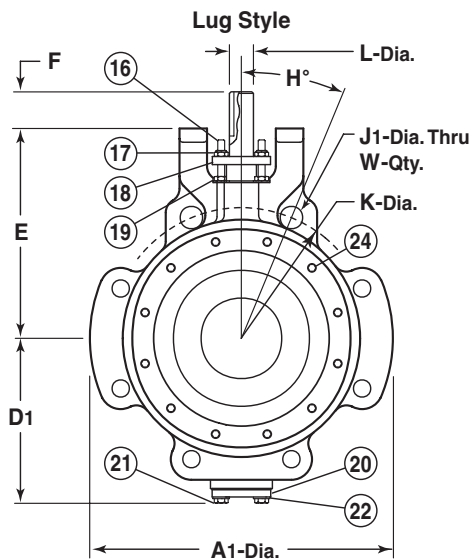

Size	Dimension (in.) - ANSI Class 150																							
	A	A1	B	C	D	D1	E	F	G	H	J	J1	K	L	N	P	R	S	T	U	V	W	X	Y
2.5	4.69	6.75	1.06	1.88	3.00	3.00	4.75	1.00	2.19	45.00	.69	5/8-11	5.50	.56	.38	—	—	1.078	1.50	3.25	.344	4	.75	1.63
3	5.19	7.25	1.06	1.88	3.25	3.31	5.13	1.00	2.81	45.00	.69	5/8-11	6.00	.56	.38	—	—	1.078	1.50	3.25	.344	4	.75	1.63
4	6.50	8.88	1.06	2.13	3.94	4.94	6.25	1.00	3.88	22.50	.69	5/8-11	7.50	.63	.50	—	—	1.078	2.00	3.50	.406	8	1.00	1.75
5	7.56	10.00	1.25	2.25	4.56	5.44	7.06	1.00	4.75	22.50	.81	3/4-10	8.50	.88	.63	—	—	1.078	2.00	3.50	.406	8	1.00	1.75
6	8.63	11.00	1.25	2.25	5.00	5.88	7.63	1.00	5.75	22.50	.81	3/4-10	9.50	.88	.63	—	—	1.078	2.00	3.50	.406	8	1.00	1.75
8	10.81	13.50	1.44	2.50	6.19	7.00	9.63	1.75	7.63	22.50	.81	3/4-10	11.75	1.13	.88	—	—	1.828	2.56	4.00	.563	8	1.28	2.00
10	12.88	16.00	1.63	2.81	7.25	8.44	10.22	2.94	9.69	15.00	.94	7/8-9	14.25	1.13	—	.25	.984	2.25	3.25	4.75	.563	12	1.63	2.38
12	15.25	19.00	1.75	3.19	8.75	10.00	11.94	3.00	11.69	15.00	.94	7/8-9	17.00	1.25	—	.38	1.033	2.25	3.50	5.00	.688	12	1.75	2.50

Dimensions (millimeters) - ANSI Class 150

Keyed Stem
10"-24" Cl. 150
8"-12" Cl. 300

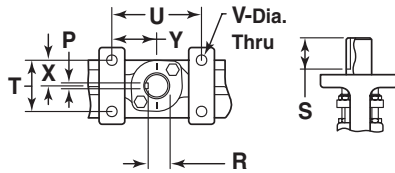

Flatted Stem
2 1/2"-8" Cl. 150
3"-6" Cl. 300

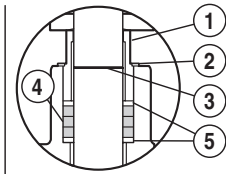
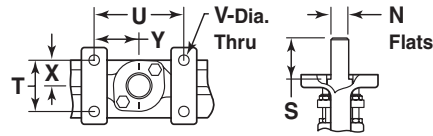

Stem Detail

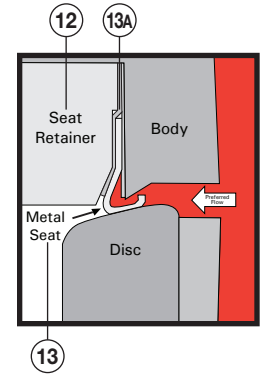
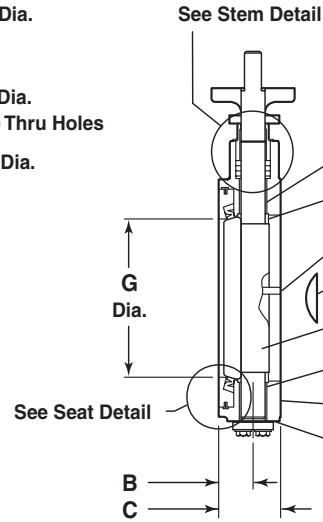
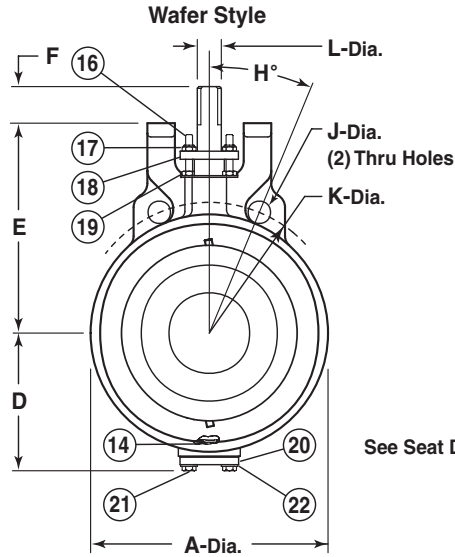
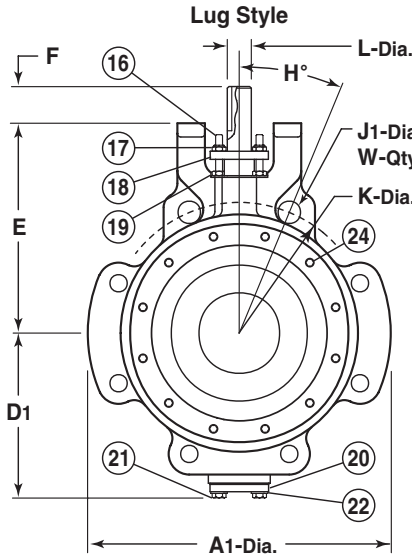

Size	Dimension (mm) - ANSI Class 150																							
	A	A1	B	C	D	D1	E	F	G	H	J	J1	K	L	N	P	R	S	T	U	V	W	X	Y
2.5	119.1	171.5	26.9	47.8	76.2	76.2	120.7	25.4	55.6	1143	17.5	5/8 - 11	139.7	14.2	9.7	—	—	27.4	38.1	82.6	8.7	4	19.1	41.4
3	131.8	184.2	26.9	47.8	82.6	84.1	130.3	25.4	71.4	1143	17.5	5/8 - 11	152.4	14.2	9.7	—	—	27.4	38.1	82.6	8.7	4	19.1	41.4
4	165.1	225.6	26.9	54.1	100.1	125.5	158.8	25.4	98.6	571.5	17.5	5/8 - 11	190.5	16	12.7	—	—	27.4	50.8	88.9	10.3	8	25.4	44.5
5	192	254	31.8	57.2	115.8	138.2	179.3	25.4	120.6	571.5	20.6	3/4 - 10	215.9	22.4	16	—	—	27.4	50.8	88.9	10.3	8	25.4	44.5
6	213.2	279.4	31.8	57.2	127	149.4	193.8	25.4	146.1	571.5	20.6	3/4 - 10	241.3	22.4	16	—	—	27.4	50.8	88.9	10.3	8	25.4	44.5
8	274.6	342.9	36.6	63.5	157.2	177.8	224.6	44.5	193.8	571.5	20.6	3/4 - 10	298.5	28.7	22.4	—	—	46.4	65	101.6	14.3	8	32.5	50.8
10	327.2	406.4	41.4	71.4	184.2	214.4	259.6	74.7	246.1	381	23.9	7/8 - 9	362	28.7	—	6.4	25	57.2	82.6	120.7	14.3	12	41.4	60.5
12	387.4	482.5	44.5	81	222.3	254	303.3	76.2	296.9	381	23.9	7/8 - 9	431.8	31.8	—	9.7	26.2	57.2	88.9	127	17.5	12	44.5	63.5

See the back of this catalogue for more information and a guide on how to order



Dimensions - ANSI Class 300

Keyed Stem
10"-24" Cl. 150
8"-12" Cl. 300

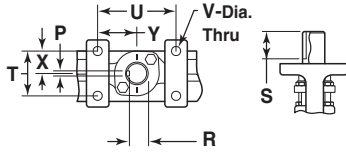

Flatted Stem
2 1/2"-8" Cl. 150
3"-6" Cl. 300

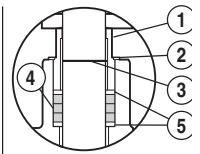
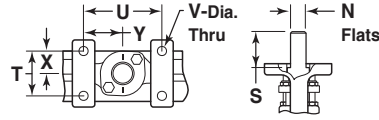

Upper and Lower Stem Detail

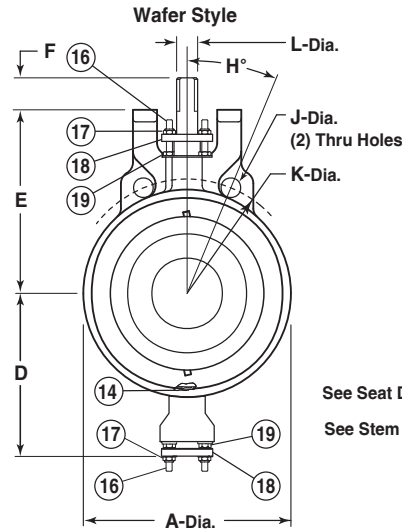
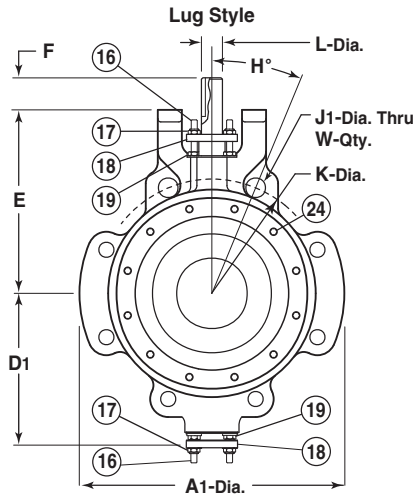

See Stem Detail

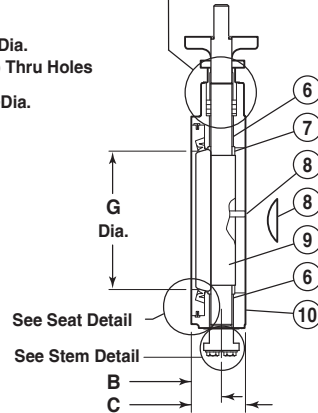

See Seat Detail

See Stem Detail

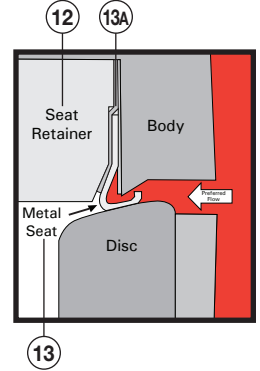

Size (in)	Dimensions (in.) - ANSI Class 300																							
	A	A1	B	C	D	D1	E	F	G	H	J	J1	K	L	N	P	R	S	T	U	V	W	X	Y
3	5.19	8.25	1.06	1.88	5.75	5.75	5.81	1.00	2.81	22.50	.81	3/4-10	6.63	.56	.38	-	-	1.078	1.50	3.25	.344	8	.75	1.63
4	6.50	9.38	1.06	2.13	6.69	6.69	6.75	1.00	3.88	22.50	.81	3/4-10	7.88	.63	.50	-	-	1.078	2.00	3.50	.406	8	1.00	1.75
6	8.63	12.00	1.25	2.31	7.88	7.88	8.25	1.00	5.75	15.00	.81	3/4-10	10.63	.88	.63	-	-	1.078	2.00	3.50	.406	12	1.00	1.75
8	10.63	15.00	1.61	2.88	9.50	9.50	10.25	2.31	7.50	15.00	.94	7/8-9	13.00	1.25	-	.38	1.03	2.38	3.25	4.75	.563	12	1.63	2.38
10	13.13	17.50	1.56	3.25	12.19	12.19	12.81	3.00	9.50	11.25	.106	1-8	15.25	1.38	-	.38	1.16	3.00	3.25	4.75	.563	16	1.63	2.38
12	15.50	20.50	2.00	3.63	15.31	15.31	15.00	3.00	11.30	11.25	1 1/8-8	1 1/8-8	17.75	1.75	-	.38	1.53	2.75	4.75	6.25	.688	16	2.38	3.13

Size (in)	Dimensions (mm.) - ANSI Class 300																							
	A	A1	B	C	D	D1	E	F	G	H	J	J1	K	L	N	P	R	S	T	U	V	W	X	Y
3	131.8	209.6	26.9	47.8	146.1	146.1	147.6	25.4	71.4	571.5	20.6	3/4-10	168.4	14.2	9.7	-	-	27.4	38.1	82.6	8.7	8	19.1	41.4
4	165.1	238.3	26.9	54.1	169.9	169.9	171.5	25.4	98.6	571.5	20.6	3/4-10	200.2	16.0	12.7	-	-	27.4	50.8	88.9	10.3	8	25.4	44.5
6	219.2	304.8	31.8	58.7	200.2	200.2	209.6	25.4	146.1	381.0	20.6	3/4-10	270.0	22.4	16.0	-	-	27.4	50.8	88.9	10.3	12	25.4	44.5
8	270.0	381.0	40.9	73.2	241.3	241.3	260.4	58.7	190.5	381.0	23.9	7/8-9	330.2	31.8	-	9.7	26.2	60.5	82.6	120.7	14.3	12	41.4	60.5
10	333.5	444.5	39.6	82.6	309.6	309.6	352.4	76.2	241.3	285.8	26.9	1-8	387.4	35.1	-	9.7	29.5	76.2	82.6	120.7	14.3	16	41.4	60.5
12	393.7	520.7	50.8	92.2	388.9	388.9	381.0	76.2	287.0	285.8	28.7	1 1/8-8	450.9	44.5	-	9.7	38.9	69.9	12.7	158.8	17.5	16	60.5	79.5

Size (in)	Weight in LBS (Bare Stem)							
	2 1/2"	3"	4	5"	6"	8"	10"	12"
1150/2150	10	12	16	25	30	50	80	150
1151/2151	15	17	23	37	42	70	115	210
1300/2300	N/A	19	23	N/A	37	60	92	176
1301/2301	N/A	23	30	N/A	50	80	125	240



Technical Data

Valve Operating and Rating Information

Pressure Rating at 100°F

Class 150: 285 PSIG (A216 Gr. WCB)
275 PSIG (A351 Gr. CF8M)

Class 300: 740 PSIG (A216 Gr. WCB)
720 PSIG (A351 Gr. CF8M)

Seat Leakage Class

Class IV

Minimum Operating Temperature

-35°F

Technical Charts and Data

Flow Coefficients (Cv)

Valve Size (in.)	Cv Flow Coefficient	
	Class 150	Class 300
2½	90	—
3	205	205
4	403	403
5	640	—
6	1075	1075
8	2243	1950
10	3885	3100
12	5925	4400

Flow Characteristics Curve

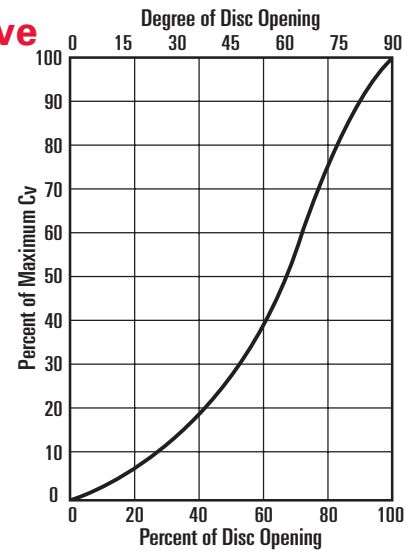

Note: Flow coefficients (Cv) based on ambient water temperature

Pressure Temperature Chart

ANSI Class 150 and 300

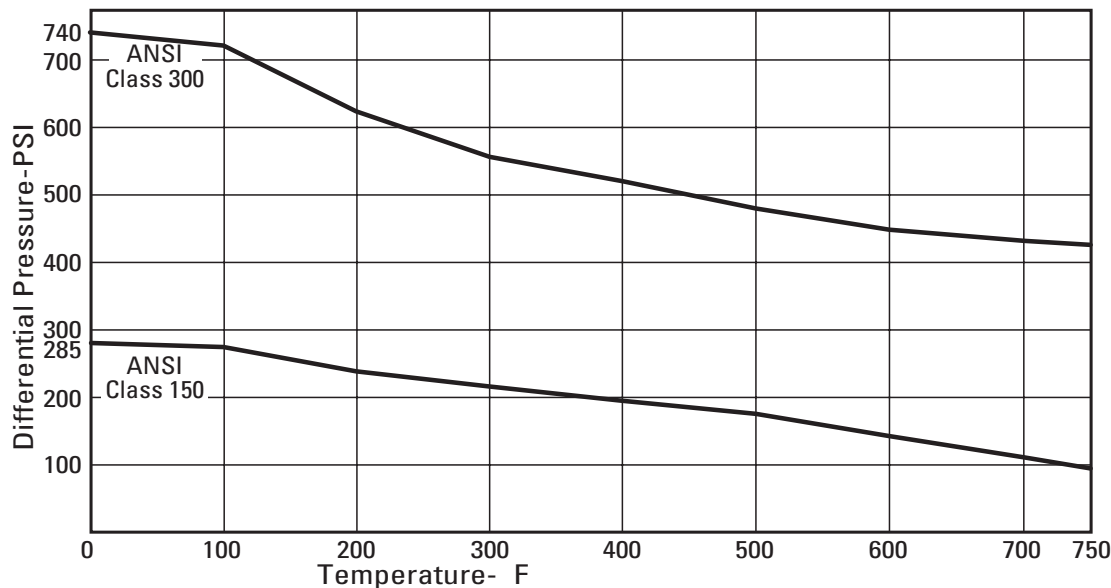

Note: Maximum continuous operating temperature. Consult factory for application above those shown.

Technical Data

Torque - ANSI Class 150

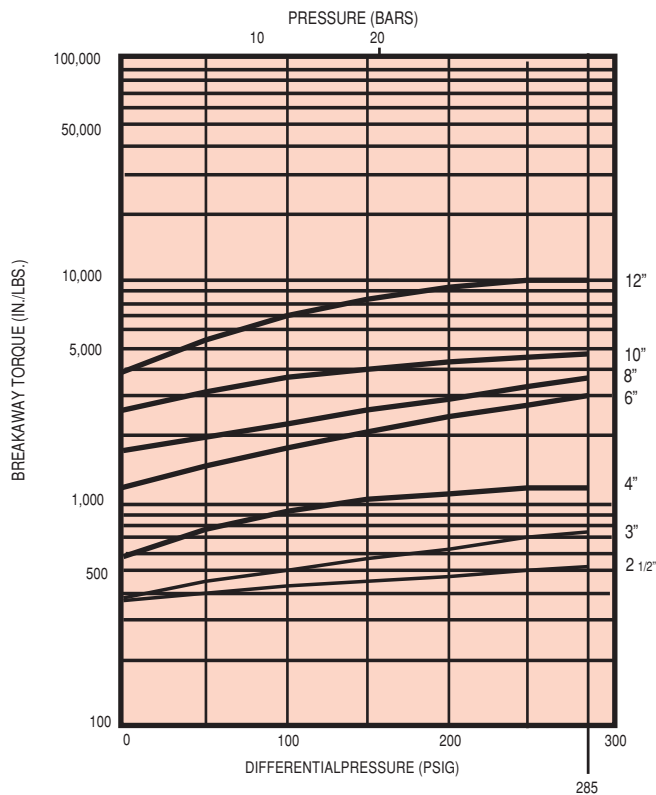

Note: Torques based on clean service only.
Certain highly viscous or abrasive services could increase these values.

Torque - ANSI Class 300

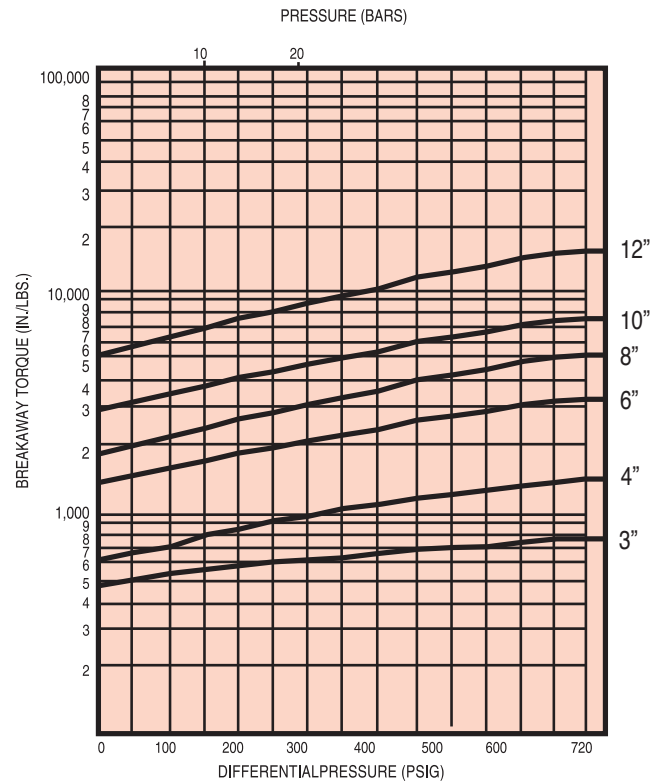

Note: Torques based on clean service only.
Certain highly viscous or abrasive services could increase these values.

Torque in LBS									
PSIG	100		200		285		400	600	740
Size	150#	300#	150#	300#	150#	300#	300#	300#	300#
3"	500	500	610	610	720	720	750	775	825
4"	900	900	1100	1100	1300	1300	1400	1500	1700
5"	N/A	N/A	N/A	N/A	N/A	N/A	N/A	N/A	N/A
6"	1600	1600	2400	2400	3000	3000	3200	3400	3500
8"	2300	2500	2900	3200	3500	3500	4000	4700	5000
10"	3700	4000	4400	4500	4600	5300	5800	7000	7500
12"	7000	7700	9100	9400	9900	9900	10000	12500	13500



How to Order

Quarter-Flex High Performance Butterfly Valve

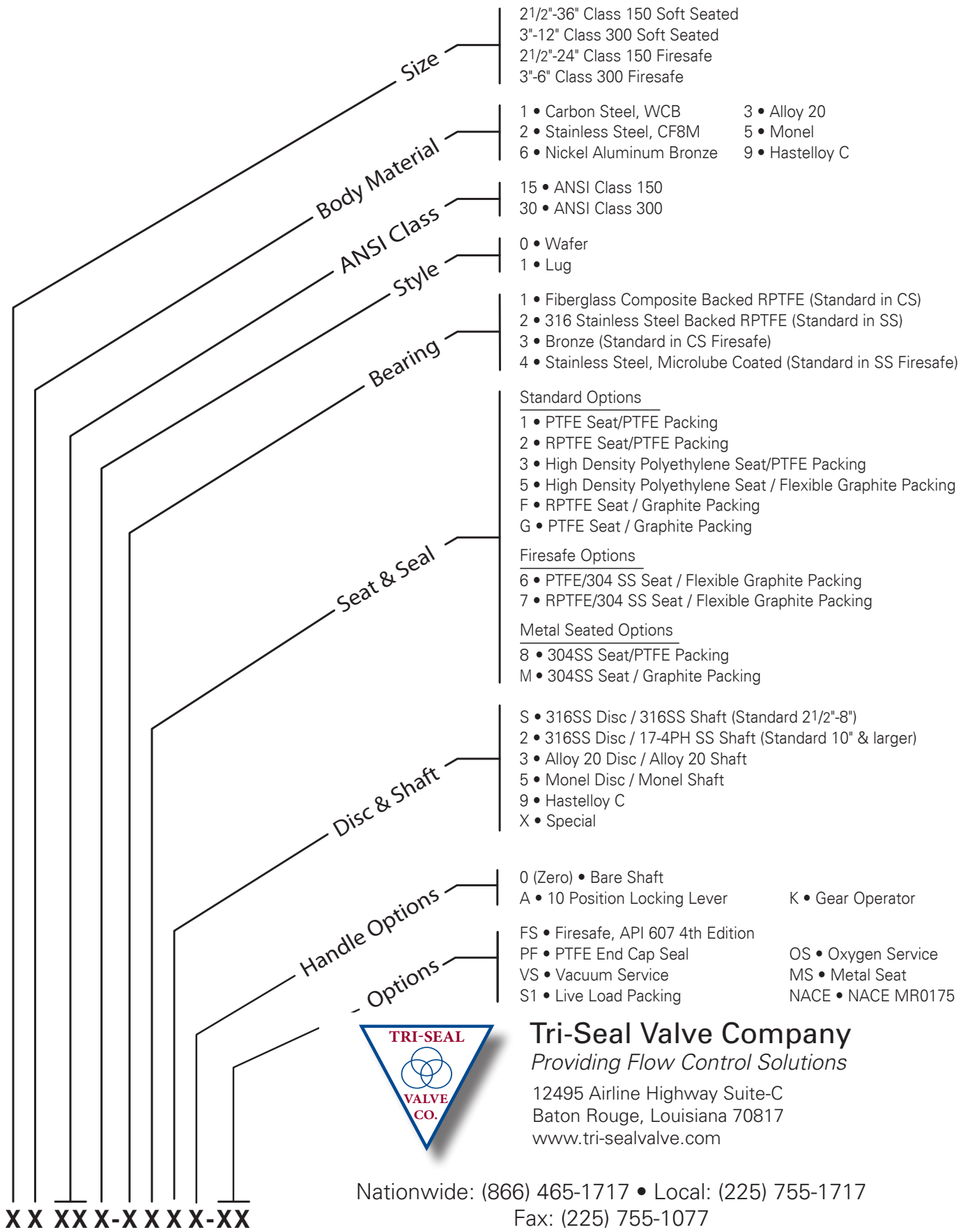

Tri-Seal Valve Company

Providing Flow Control Solutions

12495 Airline Highway Suite-C
 Baton Rouge, Louisiana 70817
www.tri-sealvalve.com

Nationwide: (866) 465-1717 • Local: (225) 755-1717
 Fax: (225) 755-1077