

Contromatics

Flanged Floating Ball Valves

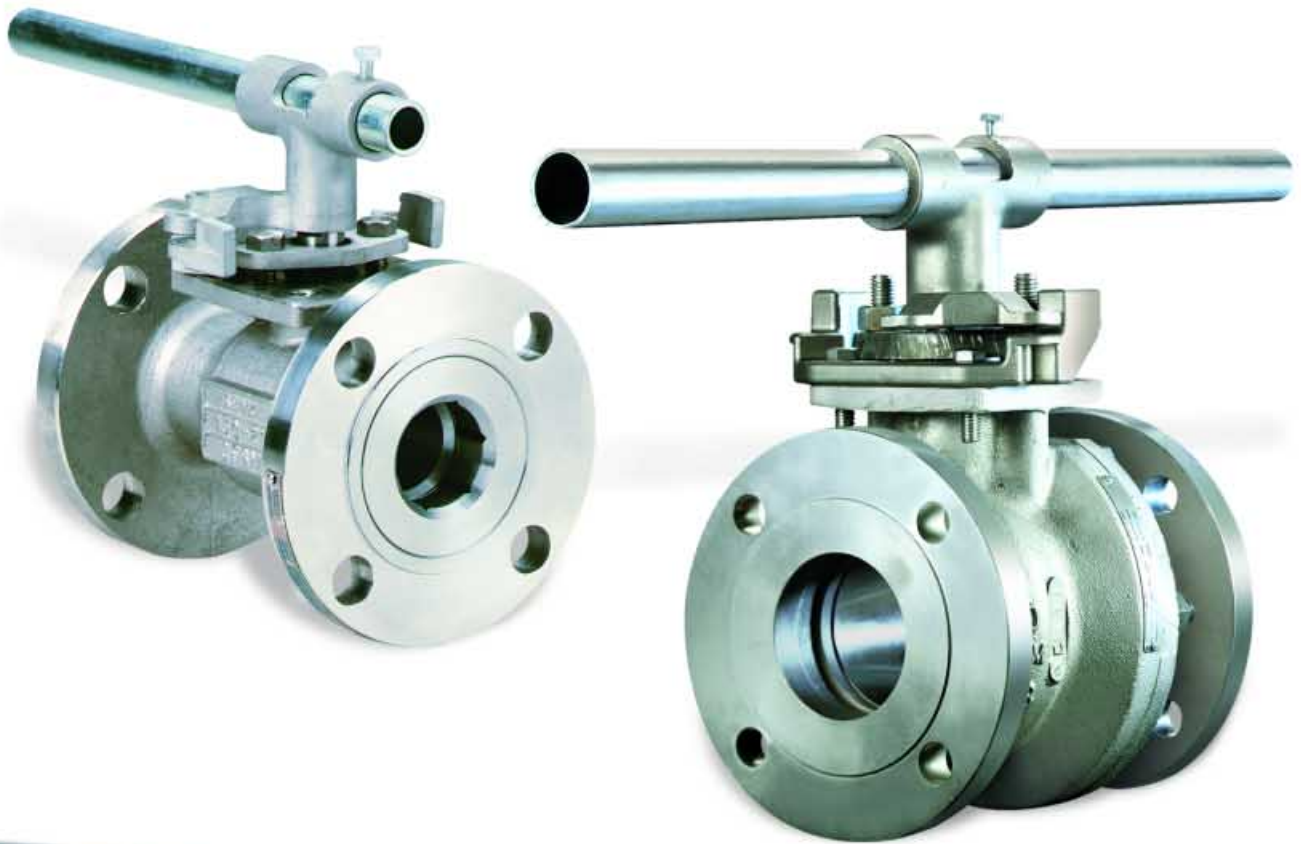

Superior Fluid Control Products
A **CIRCOR** Energy Products Brand

Contromatics Flanged Floating Ball Valves

Contromatics Flanged Floating Ball Valves are a prime example of reliability, performance, manufacturing and superior engineering techniques at work. Featuring a unibody or two-piece bolted design.

General Design Features

- NACE MR0175/ISO 15156 (Stainless Steel Ball/Stem Configuration)
- Blowout Proof Stem
- Actuator Mounting Pad (4 Bolt Machined)
- API 607 4th Edition*
- 316SS Ball/Stem Standard
- Full Rated Bi-Directional Dead End Service
- Antistatic Device
- Integral Seat Lip
- Lockable Handle
- Graphite or PTFE Packing

*Not applicable to PTFE packed valves.

Size Range & Design Availability

Size (in.)	Class/Configuration	
	150	300
1/2 RP	■	■
3/4 RP	■	■
1 RP	■	■
1 FP	▲	▲
1 1/2 RP	■	■
1 1/2 FP	▲	▲
2 RP	■	■
2 FP	▲	▲
2 1/2 RP	■	—
3 RP	■	■

■ Unibody ▲ Split Body

Size (in.)	Class/Configuration	
	150	300
3 FP	▲	▲
4 RP	■	■
4 FP	▲	▲
6 RP	■	■
6 FP	▲	▲
8 RP	▲	▲
8 FP	▲	▲
10 RP	▲	—
10 FP	▲	—

Applicable Standards

API-American Petroleum Institute

Std. 598 Valve inspection and test.

Std. 607 Fire test for soft seated quarter-turn valves.

ASME/ANSI-American National Standard

B16.5 Steel pipe flanges and flanged fittings.

B16.10 Face-to-face and end-to-end dimensions of ferrous valves.

B16.34 Steel valves- Flanged and butt welding ends.

B31.3 Chemical plant and petroleum refinery piping.

EC-European Community

CE Marked (P.E.D. 97/23/EC)*

ISO-International Organization for Standardization

ISO 9001: Quality systems-Model for quality assurance in design/development, production, installation and servicing.

ISO 15156 Materials for use in H₂S containing environments in oil and gas production.

MSS-Manufacturers Standardization Society

SP 6 Std. finishes for contact faces of pipe flanges and connecting - end flanges of valves and fittings.

SP 25 Standard marking system for valves, fittings, flanges and unions.

SP 55 Quality standard for steel castings-visual method.

NACE-National Assoc. of Corrosion Engineers

MR0175 Sulfide stress cracking resistant metallic materials for oilfield equipment.

Contents

Features & Design Availability	2
Applicable Standards.....	2
Part Number Codes	3
Component Parts, Unibody	4
Component Parts, Split Body	5
Dimensional Data	
Unibody Ball Valves, Class 150 & 300.....	6, 7
Split Body Ball Valves, Class 150 & 300	8, 9
Topworks	10
Mounting Kits, GOPs & Actuation	11-13
Engineering Data	14
Automation Features & Options	15

*P.O.A. consult factory.

Contromatics Flanged Floating Ball Valves

How To Order

Code numbers fully describe a valve. They are made up of size and figure designations based upon the following code:

Example: 2" Carbon Steel, Reduced Port, Class 150, 316SS Ball and Stem, PTFE Seats and Seals. 316SS Trim and Stainless Lever Locking Handle are Standard.

2"		1	50	1	—	2	1	2	A	—	X	—	X	—	X
1		2	3	4	—	5	6	7	8	—	9	—	10	—	11

1 • Size

1/2" - 10"	Reduced Port (Unibody Design through 6")
1" - 10"	Full Port 2-Piece

2 • Body Material

1	Carbon Steel, WCB
2	Stainless Steel, CF8M
3	Alloy 20-CN7M*

3 • Port

50	Reduced Port Unibody (8" 2-Piece Body)
80	Full Port 2-Piece

4 • ANSI Class

1	ANSI Class 150
3	ANSI Class 300

5 • Seat Material

2	Uniseal™
4	Mineral Filled PTFE
7	PEEK™

6 • Packing

1	PTFE V-Ring
6	Graphite (FS Option)

7 • Ball & Stem

2	316 Stainless Steel
3	Alloy 20*
5	Monel®*

8 • Operator Options

Blank	Bare Shaft
A	Lever Locking Handle
C	Oval Locking Handle (1 1/2" & Larger)
OVL	Oval Locking Handle (1/2" RP- 1" RP)
K	Gear Operator
H	Extended Locking
HOV	Extended Oval Locking

9 • Options

FS	Firesafe to API 607 4th Edition
AD	Assembled Dry
V	Vented Ball
G	Grounded Ball & Stem
O	Oxygen Service*
AB	Alloy 20 Body Bolts & Nuts*
CL	Chlorine Service*

10 • Design Options

S1	Live Loaded Stem Packing (1 1/2" & Larger)
----	--

11 • Model Revision

M2	Current Model
----	---------------

*P.O.A. consult factory.

Contromatics Unibody Component Parts

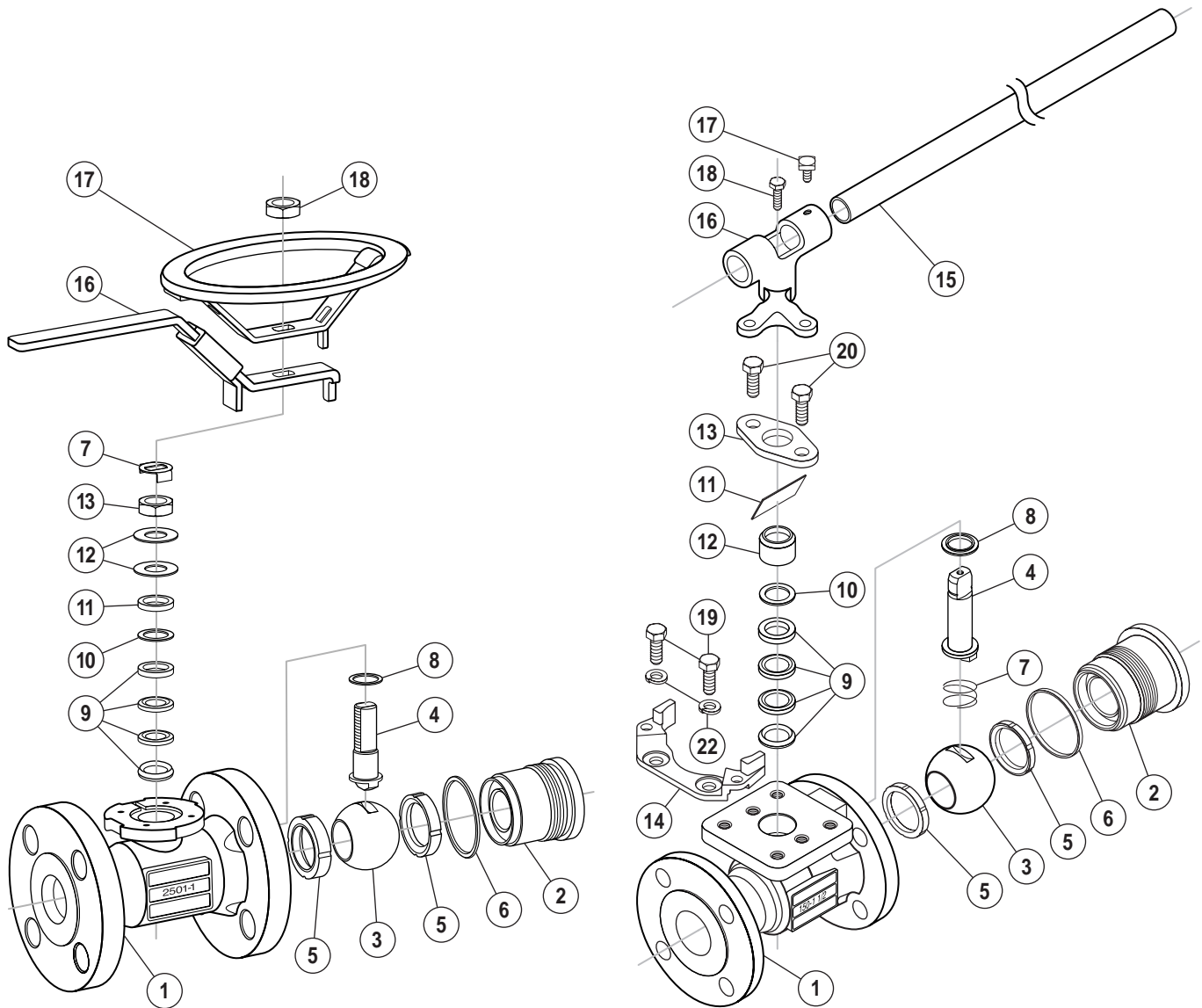

Parts List, 1/2" - 1" RP

Part No.	Description
1	Body
2	Seat Retainer
3	Ball
4	Stem
5	Seat
6	Body Seal
7	Stem Nut Lock Washer
8	Thrust Washer

Part No.	Description
9	Packing
10	Thrust Washer-Upper
11	Gland Follower
12	Spring Washer
13	Packing Nut
16	Locking Lever Handle
17	Locking Oval Handle
18	Nut, Handle

Parts List, 1 1/2" - 6" RP

Part No.	Description
1	Body
2	Seat Retainer
3	Ball
4	Stem
5	Seat
6	Body Seal
7	Ground Spring
9	Packing
10	Ground Washer
11	Tape Liner

Part No.	Description
12	Gland Follower
13	Gland Retainer
14	Lock Stop Plate
15	Handle Pipe
16	Locking T-Handle
17	Set Screw, Pipe
18	Screw, Handle
19	Stop Plate Screw
20	Gland Bolt
22	Stop Plate Washer

Contromatics Split Body Component Parts

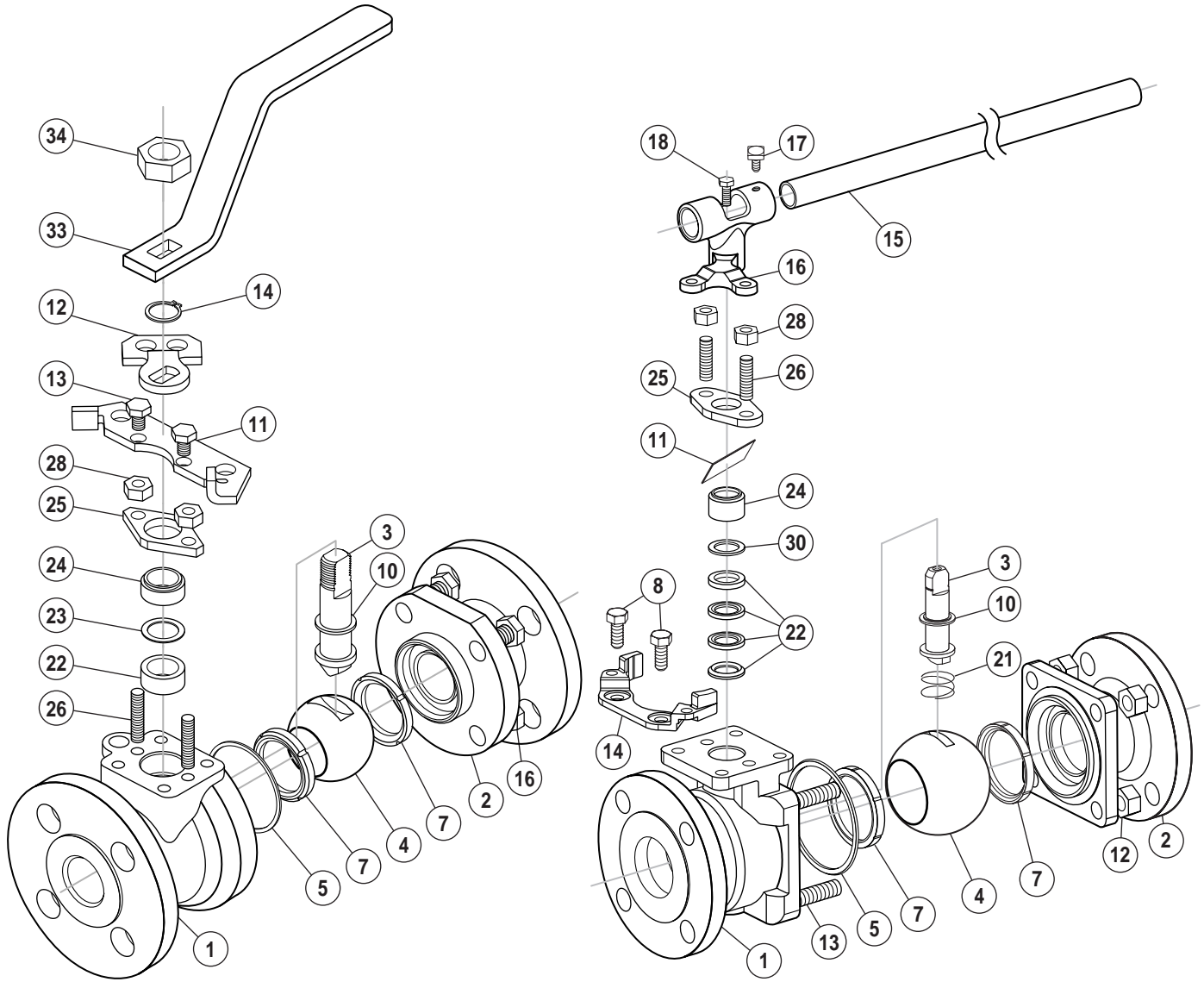

Parts List, 1" FP

Part No.	Description
1	Body
2	Adapter
3	Stem
4	Ball
5	Body Gasket
7	Seat, Delrin
10	Thrust Bearing
11	Stop Plate
12	Locking Stop
13	Screws, Stop Plate

Part No.	Description
14	Retainer
16	Body Screws
22	Teflon® Packing
23	Ground Washer
24	Follower
25	Packing Retainer
26	Packing Studs
28	Packing Nuts
33	Handle
34	Handle Nut

Parts List, 1 1/2" - 10" FP & 8" - 10" RP

Part No.	Description
1	Body
2	Adapter
3	Stem
4	Ball
5	Body Gasket
7	Seat
8	Stop Plate Screw
10	Thrust Washer
11	Tape Liner
14	Lock Stop Plate

Part No.	Description
15	Handle Pipe
16	Locking T-Handle
17	Set Screw, Pipe
18	Screw, Handle
21	Grounding Spring
22	Gland Packing
24	Gland Follower
25	Packing Gland Retainer
26	Stud Packing
28	Nut Packing
30	Stem Washer

Contromatics Unibody, Dimensional Data (in.), Class 150 & 300

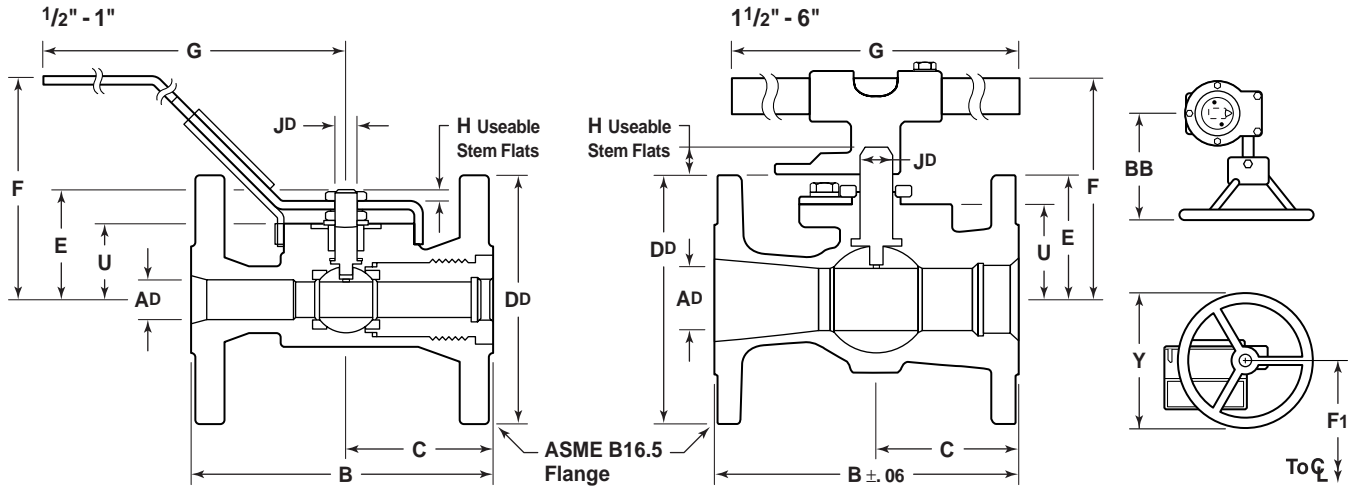

Dimensional Data (in.), 1/2\" - 1\" & 1 1/2\" - 6\", Class 150, Reduced Port

Size (in.)	Dimension (in.)													Wt. (lbs.)
	A ^D	B	C	D ^D	E	F	F ₁	G	H	J ^D	U	Y	BB	
1/2	.50	4.25	2.07	3.50	1.58	3.36	—	6.06	.278*	.313	1.07	—	—	3.0
3/4	.66	4.62	2.31	3.88	1.91	3.36	—	7.06	.240	.375	1.27	—	—	4.8
1	.88	5.00	2.30	4.25	2.55	3.64	—	7.06	.330	.500	1.54	—	—	6.2

*For .278 in. usable stem flat, the top jam nut must be removed.

Size (in.)	Dimension (in.)													Wt. (lbs.)
	A ^D	B	C	D ^D	E	F	F ₁	G	H	J ^D	U	Y	BB	
1 1/2	1.25	6.50	3.15	5.00	3.58	5.25	7.32	17.00	.70	.75	2.26	6	6.00	12.8
2	1.50	7.00	3.27	6.00	3.69	5.36	7.37	17.00	.70	.75	2.31	6	6.00	17.6
2 1/2	2.00	7.50	3.32	7.00	4.12	5.79	7.82	17.00	.70	.75	2.76	6	6.00	27.1
3	2.42	8.00	3.46	7.50	4.38	6.05	8.12	17.00	.70	.75	3.06	6	6.00	31.5
4	3.00	9.00	4.10	9.00	6.75	8.83	11.63	22.00	1.88	1.06	4.43	8	7.50	54.2
6	4.50	10.50	5.25	11.00	8.56	10.55	13.22	22.00	1.44	1.34	6.02	8	7.50	137.0

Dimensional Data (in.), 1/2\" - 1\" & 1 1/2\" - 6\", Class 300, Reduced Port

Size (in.)	Dimension (in.)													Wt. (lbs.)
	A ^D	B	C	D ^D	E	F	F ₁	G	H	J ^D	U	Y	BB	
1/2	.500	5.50	1.58	3.75	1.487	2.549	—	6.06	.32	.32	.877	—	—	6.0
3/4	.656	6.00	2.01	4.62	1.824	2.814	—	7.06	.39	.38	1.104	—	—	8.0
1	.875	6.50	1.83	4.88	2.268	3.858	—	8.06	.56	.50	1.358	—	—	9.8

Size (in.)	Dimension (in.)													Wt. (lbs.)
	A ^D	B	C	D ^D	E	F	F ₁	G	H	J ^D	U	Y	BB	
1 1/2	1.25	7.50	3.15	6.12	3.58	5.25	7.32	17.00	.70	.75	2.26	6	6.00	20.0
2	1.50	8.50	3.27	6.50	3.69	5.36	7.37	17.00	.70	.75	2.31	6	6.00	26.0
3	2.42	11.12	3.96	8.25	4.38	6.05	8.12	17.00	.70	.75	3.06	6	6.00	46.0
4	3.00	12.00	4.10	10.00	6.75	8.83	11.63	22.00	1.38	1.06	4.43	8	7.50	70.0
6	4.50	15.88	5.25	12.50	8.56	10.55	13.22	22.00	1.44	1.34	6.02	8	7.50	157.0

Contromatics Unibody, Dimensional Data (mm), Class 150 & 300

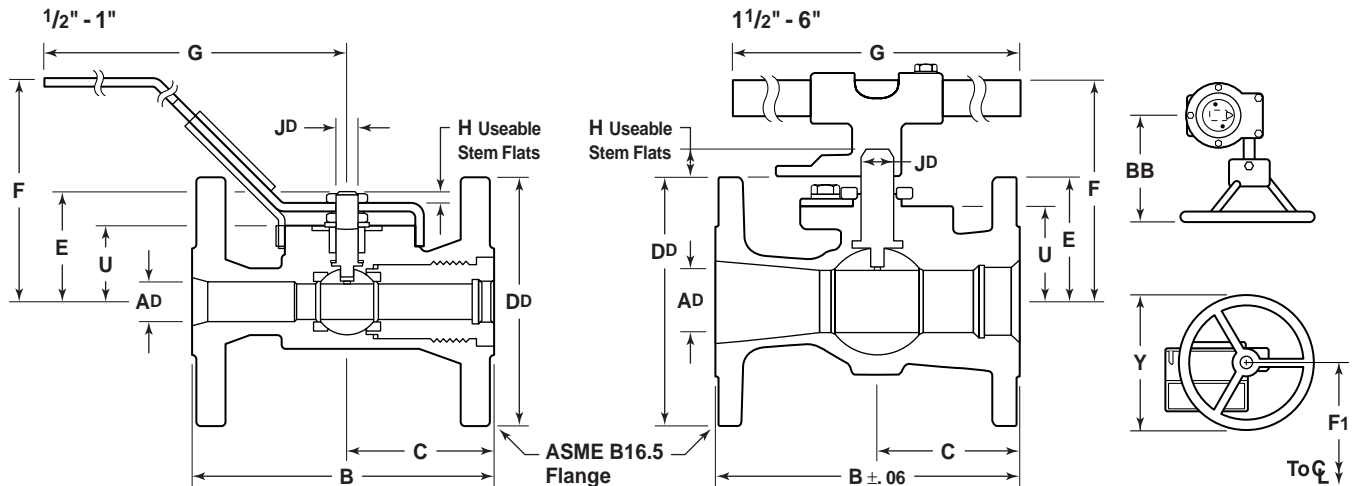

Dimensional Data (mm), 1/2"- 1" & 1 1/2"- 6", Class 150, Reduced Port

Size (in.)	Dimension (mm)													Wt. (kg)
	A ^D	B	C	D ^D	E	F	F ₁	G	H	J ^D	U	Y	BB	
1/2	12.7	108.0	52.6	88.9	40.1	85.3	—	153.9	7.1*	8.0	27.2	—	—	1.36
3/4	16.8	117.6	58.7	98.6	48.5	85.3	—	179.3	6.1	9.5	32.3	—	—	2.18
1	22.4	127.0	58.4	108.0	64.8	92.5	—	179.3	8.4	12.7	39.1	—	—	2.81

*For 7.1 mm usable stem flat, the top jam nut must be removed.

Size (in.)	Dimension (mm)													Wt. (kg)
	A ^D	B	C	D ^D	E	F	F ₁	G	H	J ^D	U	Y	BB	
1 1/2	31.8	165.1	80.0	127	90.9	133.4	185.9	431.8	17.8	19.1	57.4	152.4	152.4	5.81
2	38.1	177.8	83.1	152.4	93.7	136.1	187.2	431.8	17.8	19.1	58.7	152.4	152.4	7.98
2 1/2	50.8	190.5	84.3	177.8	104.6	147.1	198.6	431.8	17.8	19.1	70.1	152.4	152.4	12.29
3	61.5	203.2	87.9	190.5	111.3	153.7	206.2	431.8	17.8	19.1	77.7	152.4	152.4	14.29
4	76.2	228.6	104.1	228.6	171.5	224.3	295.4	558.8	47.8	26.9	112.5	203.2	190.5	24.58
6	114.3	266.7	133.4	279.4	217.4	268.0	335.8	558.8	36.6	34.0	152.9	203.2	190.5	62.14

Dimensional Data (mm), 1/2"- 1" & 1 1/2"- 6", Class 300, Reduced Port

Size (in.)	Dimension (mm)													Wt. (kg)
	A ^D	B	C	D ^D	E	F	F ₁	G	H	J ^D	U	Y	BB	
1/2	12.7	139.7	40.1	95.3	37.8	64.7	—	153.9	8.1	8.1	22.3	—	—	2.72
3/4	16.7	152.4	51.1	117.3	46.3	71.5	—	179.3	9.9	9.7	28.0	—	—	3.63
1	22.2	165.1	46.5	124.0	57.6	98.0	—	204.7	14.2	12.7	34.5	—	—	4.45

Size (in.)	Dimension (mm)													Wt. (kg)
	A ^D	B	C	D ^D	E	F	F ₁	G	H	J ^D	U	Y	BB	
1 1/2	31.8	190.5	80.0	155.4	90.9	133.4	185.9	431.8	17.8	19.1	57.4	152.4	152.4	9.07
2	38.1	215.9	83.1	165.1	93.7	136.1	187.2	431.8	17.8	19.1	58.7	152.4	152.4	11.79
3	61.5	282.4	100.6	209.6	111.3	153.7	206.2	431.8	17.8	19.1	77.7	152.4	152.4	20.87
4	76.2	304.8	104.1	254	171.5	224.3	295.4	558.8	35.1	26.9	112.5	203.2	190.5	31.75
6	114.3	403.4	133.4	317.5	217.4	268.0	335.8	558.8	36.6	34.0	152.9	203.2	190.5	71.21

Contromatics Split Body, Dimensional Data (in.), Class 150 & 300

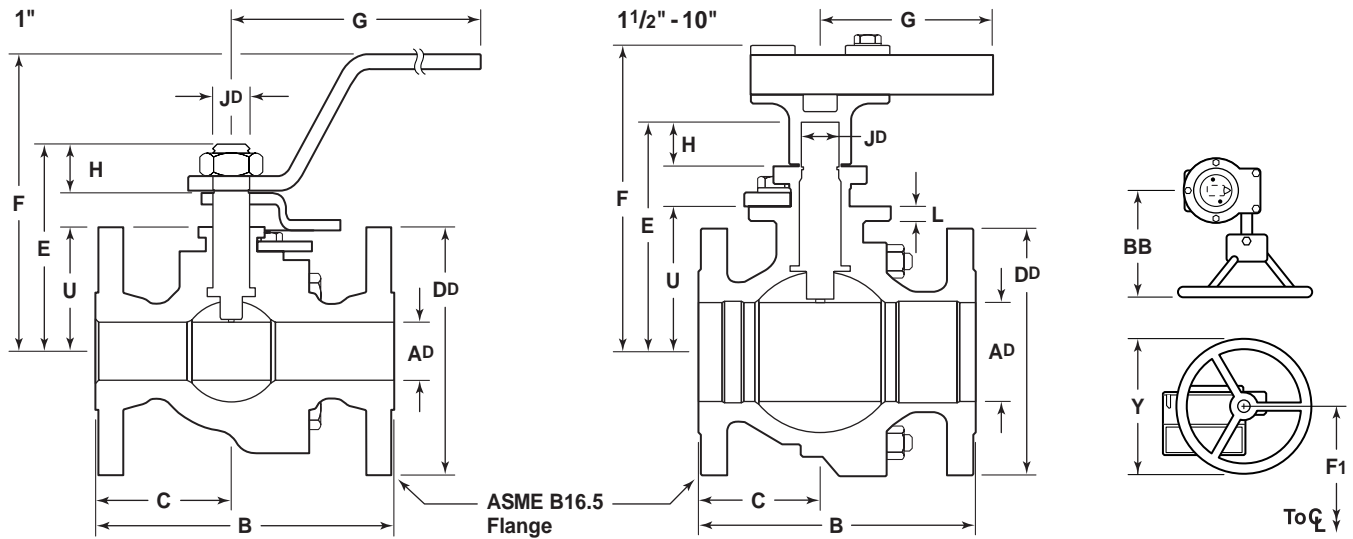

Dimensional Data (in.), 1" - 10", Class 150, Full & Reduced Port

Size (in.)	Dimension (in.)														Wt. (lbs.)
	A	B	C	D	E	F	F ₁	G	H	J	L	U	Y	BB	
1 FP	1.00	5.00	2.31	4.25	3.50	5.44	—	6.31	1.32	.623/.621	—	1.69	—	—	12.8
1 1/2 FP	1.50	6.50	2.96	5.00	3.69	5.75	7.37	15.50	.640	.746/.743	.38	2.31	6.00	6.50	12.8
2 FP	2.00	7.00	3.02	6.00	4.51	6.56	8.20	15.50	.640	.746/.743	.44	3.14	6.00	6.50	17.6
3 FP	3.00	8.00	3.50	7.50	6.81	10.25	11.63	20.00	1.28	1.069/1.064	.44	4.43	6.00	6.50	31.5
4 FP	4.00	9.00	4.00	9.00	8.40	11.00	13.08	20.00	1.28	1.339/1.334	.62	5.88	8.00	9.00	54.2
6 FP	6.00	15.50	7.75	11.00	10.81	11.12	15.63	20.00	1.45	1.559/1.554	.75	8.00	8.00	9.50	137.0
8 RP	6.00	11.50	5.13	11.00	10.81	11.12	15.63	20.00	1.45	1.559/1.554	.75	8.00	8.00	9.50	255.0
8 FP	8.00	18.00	9.00	13.50	14.25	—	17.14	—	2.27	1.999/1.994	.75	9.64	12.00	9.50	477.0
10 RP	8.00	21.00	10.50	16.00	14.25	—	17.14	—	2.27	1.999/1.994	.75	9.64	12.00	9.50	557.0
10 FP	10.00	21.00	10.50	16.00	17.41	—	22.03	—	3.06	2.499/2.494	.62	11.91	16.00	11.50	685.0

Dimensional Data (in.), 1" - 8", Class 300, Full & Reduced Port

Size (in.)	Dimension (in.)														Wt. (lbs.)
	A	B	C	D	E	F	F ₁	G	H	J	L	U	Y	BB	
1 FP	1	6.50	3.50	4.88	3.50	5.44	—	6.31	1.32	.623/.621	—	1.69	—	—	12.8
1 1/2 FP	1.50	7.50	3.53	6.13	3.69	5.75	7.37	15.50	.640	.746/.743	.38	2.31	6.00	6.50	20.0
2 FP	2.00	8.50	4.25	6.50	4.51	6.56	8.20	15.50	.640	.746/.743	.44	3.14	6.00	6.50	26.0
3 FP	3.00	11.13	5.82	8.25	6.81	10.25	11.63	20.00	1.28	1.069/1.064	.44	4.43	6.00	6.50	46.0
4 FP	4.00	12.00	6.00	10.00	8.40	11.00	13.08	20.00	1.28	1.321/1.316	.62	5.88	8.00	9.00	70.0
6 FP	6.00	15.88	7.94	12.50	12.75	14.00	15.63	48.00	2.27	1.999/1.994	.62	8.12	12.00	9.50	157.0
8 RP	6.00	19.75	9.88	15.00	12.75	—	15.63	—	2.27	1.999/1.994	.62	8.12	12.00	12.63	275.0
8 FP	8.00	19.75	9.88	15.00	16.00	—	20.64	—	3.06	2.499/2.494	.62	10.52	16.00	11.50	624.0

Contromatics Split Body, Dimensional Data (mm), Class 150 & 300

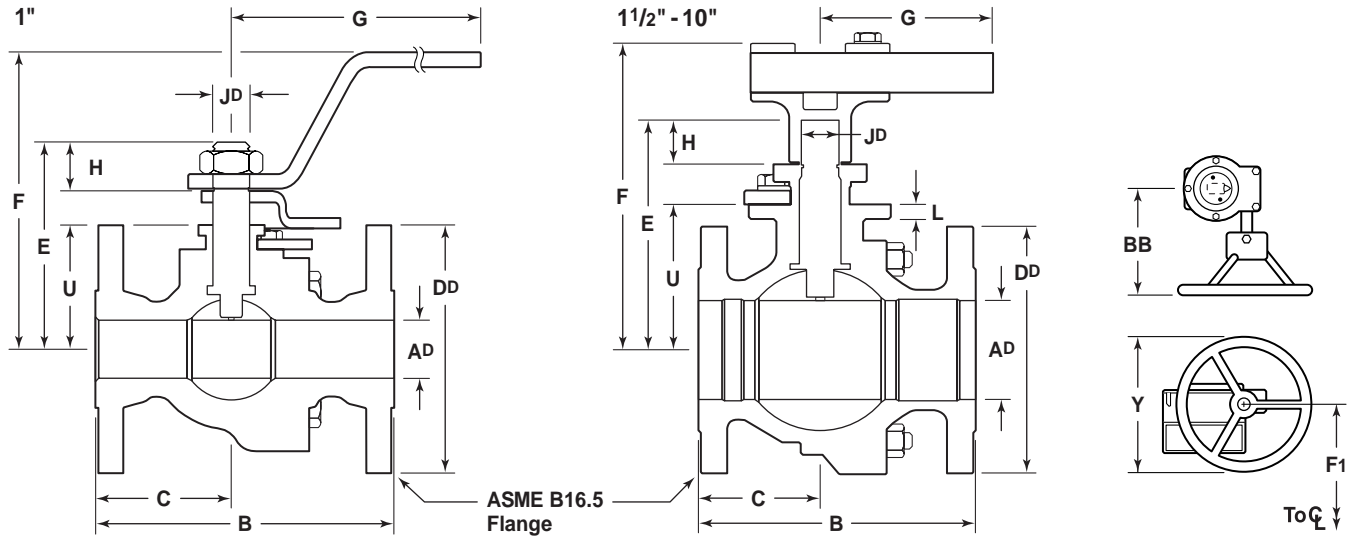

Dimensional Data (mm), 1"- 10", Class 150, Full & Reduced Port

Size (in.)	Dimension (mm)														Wt. (kg)
	A	B	C	D	E	F	F1	G	H	J	L	U	Y	BB	
1 FP	25.4	127	58.7	108.0	88.9	138.2	—	160.3	33.5	15.82/15.77	—	42.9	—	—	5.81
1 1/2 FP	38.1	165.1	75.2	127	93.7	146.1	187.2	393.7	16.3	18.95/18.87	9.7	58.7	152.4	165.1	5.81
2 FP	50.8	177.8	76.7	152.4	115.0	166.6	208.3	393.7	16.3	18.95/18.87	11.2	79.8	152.4	165.1	7.98
3 FP	76.2	203.2	88.9	190.5	173.0	260.4	295.4	508.0	32.5	27.15/27.03	11.2	112.5	152.4	165.1	14.29
4 FP	101.6	228.6	101.6	203.2	213.4	279.4	332.2	508.0	32.5	34.01/33.88	15.7	149.4	203.2	228.6	24.58
6 FP	152.4	393.7	196.9	279.4	274.6	282.4	397.0	508.0	36.8	39.60/39.47	19.1	203.2	203.2	241.3	62.14
8 RP	152.4	292.1	130.3	279.4	274.6	282.4	397.0	508.0	36.8	39.60/39.47	19.1	203.2	203.2	241.3	115.67
8 FP	203.2	457.2	228.6	342.9	362.0	—	442.0	—	57.7	50.77/50.65	19.1	244.9	304.8	241.3	216.36
10 RP	203.2	533.4	266.7	406.4	362.0	—	442.0	—	57.7	50.77/50.65	19.1	244.9	304.8	241.3	252.65
10 FP	254	533.4	266.7	406.4	442.2	—	559.6	—	77.7	63.47/63.35	15.7	302.5	406.4	292.1	310.71

Dimensional Data (mm), 1"- 8", Class 300, Full & Reduced Port

Size (in.)	Dimension (mm)														Wt. (kg)
	A	B	C	D	E	F	F1	G	H	J	L	U	Y	BB	
1 FP	25.4	165.1	88.9	124.0	88.9	138.2	—	160.3	33.5	15.82/15.77	—	42.9	—	—	5.81
1 1/2 FP	38.1	190.5	89.7	155.7	93.7	146.1	187.2	393.7	16.3	18.95/18.87	9.7	58.7	152.4	165.1	9.07
2 FP	50.8	215.9	108.0	165.1	115.0	166.6	208.3	393.7	16.3	18.95/18.87	11.2	79.8	152.4	165.1	11.79
3 FP	76.2	282.7	147.8	210.0	173.0	260.4	295.4	508	32.5	27.15/27.03	11.2	112.5	152.4	165.1	20.87
4 FP	101.6	304.8	152.4	254.0	213.4	279.4	332.2	508	32.5	33.55/33.43	15.7	149.4	203.2	228.6	31.75
6 FP	152.4	403.4	201.7	317.5	323.9	355.6	397.0	1219.2	57.7	50.77/50.65	15.7	206.2	304.8	241.3	71.21
8 RP	152.4	501.7	251.0	381.0	323.9	—	397.0	—	57.7	50.77/50.65	15.7	206.0	304.8	320.8	124.74
8 FP	203.2	501.7	251.0	381.0	406.4	—	524.3	—	77.7	63.47/63.35	15.7	267.2	406.4	292.1	283.04

Contromatics Flanged Floating Ball Valves • Topworks (in.)

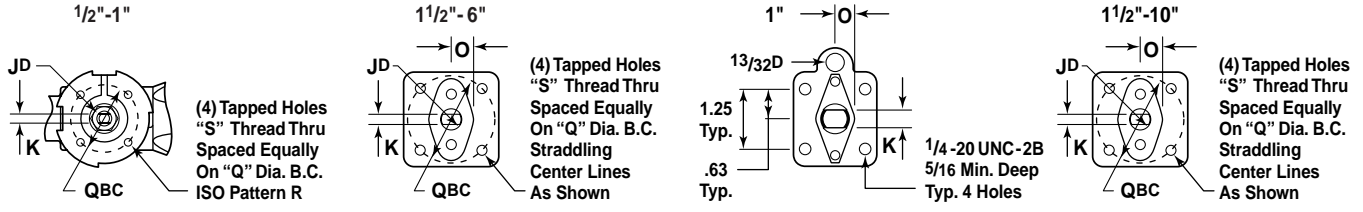

Unibody Ball Valves, Class 150 & 300

Size (in.)	Class	Dimension (in.)					
		JD	K	O	Q	R	S
1/2	150/300	.31	.190/.192	—	1.42	F03	10-32UNF
3/4	150/300	.38	.250/.252	—	1.42	F03	10-32UNF
1	150/300	.50	.276/.279	—	1.65	F04	10-32UNF
1 1/2	150/300	.75	.276/.279	.81	3.25	—	3/8-16UNC
2	150/300	.75	.376/.373	.81	3.25	—	3/8-16UNC
2 1/2	150	.75	.276/.279	.81	3.25	—	3/8-16UNC
3	150/300	.75	.376/.373	.81	3.25	—	3/8-16UNC
4	150/300	1.06	.674/.670	1.36	4.13	—	3/8-16UNC
6	150/300	1.34	.865/.861	1.36	4.41	—	3/8-16UNC

Split Body Ball Valves, Class 150 & 300

Size (in.)	Class	Dimension (in.)				
		JD	K	O	Q	S
1 x 1	150/300	.623/.621	.372/.370	.56	—	1/4-20 UNC
1 1/2 x 1 1/2	150/300	.746/.743	.376/.373	.76	3.25	3/8-16 UNC
2 x 2	150/300	.746/.743	.376/.373	.76	3.25	3/8-16 UNC
3 x 3	150/300	1.069/1.064	.674/670	1.36	4.13	3/8-16 UNC
4 x 4	150/300	1.339/1.334	.865/.861	1.36	4.41	1/2-13 UNC
6 x 6	150	1.559/1.554	1.065/1.061	1.36	5.13	5/8-11 UNC
6 x 6	300	1.999/1.994	1.249/1.245	1.58	5.13	5/8-11 UNC
8 x 6	150	1.559/1.554	1.065/1.061	1.58	5.13	5/8-11 UNC
8 x 8	150	1.999/1.994	1.249/1.245	1.58	5.13	5/8-11 UNC
8 x 8	300	2.499/2.494	1.749/1.745	2.10	6.75	3/4-10 UNC
10 x 8	150	1.999/1.994	1.249/1.245	2.10	5.13	5/8-11 UNC
10 x 10	150	2.499/2.494	1.749/1.745	2.10	6.75	3/4-10 UNC

Contromatics Flanged Floating Ball Valves • Topworks (mm)

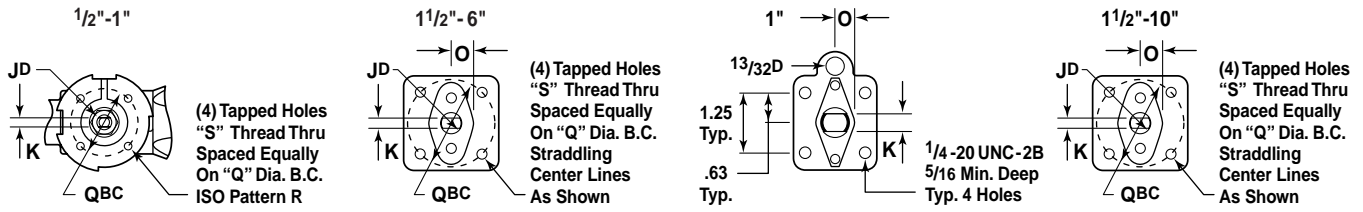

Unibody Ball Valves, Class 150 & 300

Size (in.)	Class	Dimension (mm)					
		JD	K	O	Q	R	S
1/2	150/300	8.1	4.88/4.83	—	52.3	26.2	10-32UNF
3/4	150/300	9.7	6.45/6.40	—	52.3	26.2	10-32UNF
1	150/300	12.7	7.09/6.93	—	58.7	29.4	10-32UNF
1 1/2	150/300	19.1	7.09/6.93	20.6	82.6	—	3/8-16UNC
2	150/300	19.1	9.55/9.47	20.6	82.6	—	3/8-16UNC
2 1/2	150	19.1	7.09/6.93	20.6	82.6	—	3/8-16UNC
3	150/300	19.1	9.55/9.47	20.6	82.6	—	3/8-16UNC
4	150/300	19.1	17.12/17.02	34.5	104.9	—	3/8-16UNC
6	150/300	34.0	21.97/21.87	34.5	112.0	—	1/2-13UNC

Split Body Ball Valves, Class 150 & 300

Size (in.)	Class	Dimension (mm)				
		JD	K	O	Q	S
1 x 1	150/300	15.82/15.77	9.45/9.40	14.2	—	1/4-20 UNC
1 1/2 x 1 1/2	150/300	18.95/18.87	9.55/9.47	19.3	82.6	3/8-16 UNC
2 x 2	150/300	18.95/18.87	9.55/9.47	19.3	82.6	3/8-16 UNC
3 x 3	150/300	27.15/27.03	17.12/17.02	34.5	104.9	3/8-16 UNC
4 x 4	150/300	34.01/33.88	21.97/21.87	34.5	112.0	1/2-13 UNC
6 x 6	150	39.60/39.47	27.05/26.95	34.5	130.3	5/8-11 UNC
6 x 6	300	50.77/50.65	31.72/31.62	40.13	130.3	5/8-11 UNC
8 x 6	150	39.60/39.47	21.97/21.87	40.13	130.3	5/8-11 UNC
8 x 8	150	63.47/63.35	44.42/44.32	40.13	130.3	5/8-11 UNC
8 x 8	300	2.499/2.494	1.749/1.745	53.34	171.5	3/4-10 UNC
10 x 8	150	50.77/50.65	31.72/31.62	53.34	130.3	5/8-11 UNC
10 x 10	150	63.47/63.35	44.42/44.32	53.34	171.5	3/4-10 UNC

Contromatics Mounting Kits & Gear Operators

Actuator Mounting Kits, Reduced Port

Size (in.)	Series PA/PAS Model Number												
	200	300	500	700	1030	1400	2200	2900	4100	5800	9000	12100	23600
1/2	0098984												
3/4	0098985												
1	0099157		0098986										
1 1/2	0093171		0092500			0092799		0098804					
2	0093171		0092500			0092799		0098804					
2 1/2	0093171		0092500			0092799		0098804					
3	0093171		0092500			0092799		0098804					
4			0096232			0092800		0096724					
6						0096548		0092716	0098215	0098187			
8											0092740	0092598	

Note: Based on 80 psi supply pressure.

Actuator Mounting Kits, Full Port

Size (in.)	Series PA/PAS Model Number												
	200	300	500	700	1030	1400	2200	2900	4100	5800	9000	12100	23600
1			0092838										
1 1/2	0093171		0092500			0092799		0098804					
2	0093171		0092500			0092799		0098804					
3			0096232			0092800		0096724					
4						0096548		0092716	0098215	0098187			
6											0092740	0092598	

Note: Based on 80 psi supply pressure.

Gear Operators

Size (in.)	Class 150		Class 300	
	Reduced Port	Full Port	Reduced Port	Full Port
1 1/2	0090283	0090283	0090283	0090283
2	0090283	0090283	0090283	0090283
3	0090283	0898662	0090283	0898662*
4	0898662	0898663	0898662	0898663*
6	0898663	0898665	0898663	0898665
8	0898665	0090157	0898667	0898669
10	0090157	0898670		

* Torque values are established for clean wet-line media. Other service conditions may require slightly higher torque values. Please consult factory for common service factors to be applied to the above values.

Operating Torque (in.-lbs.), Uniseal™ Seats

Size (in.)	Class 150		Class 300	
	Reduced Port	Full Port	Reduced Port	Full Port
1/2	40		40	
3/4	50		50	
1	100	130	100	130
1 1/2	180	280	180	280
2	240	440	240	500
2 1/2	440		440	
3	520	600	520	1000
4	650	1440	650	2500
6	1440	5000	1440	7000
8	5000	12,000	12,000	27,000
10	12,000	30,000		

Contromatics Series PAS Actuator Sizing

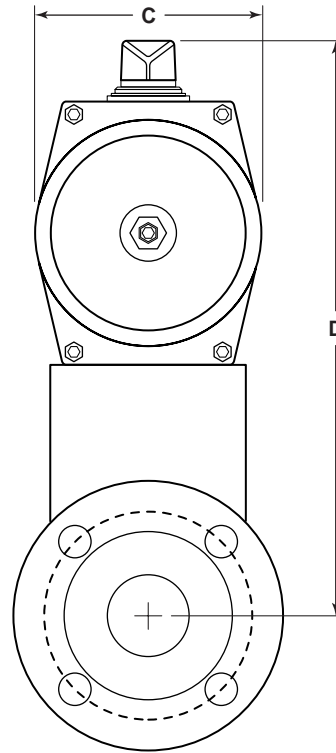
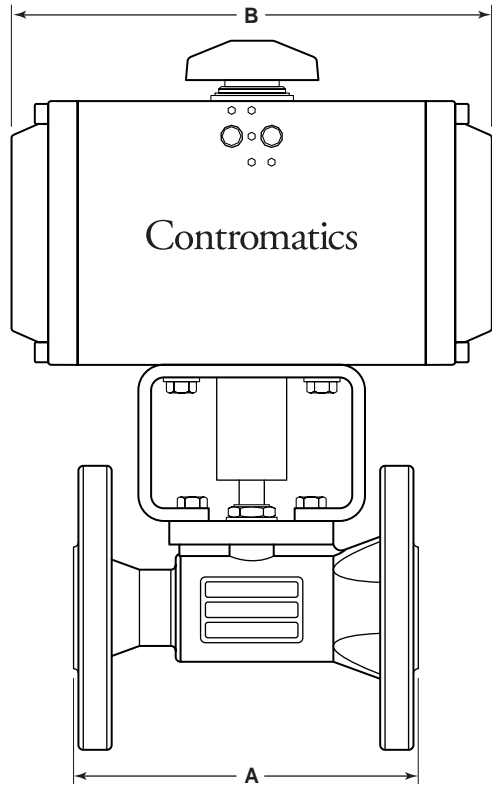

Envelope Dimensional Data (in.)

Size (in.)	Actuator Model	Dimensions (in.)				
		A / 150	A / 300	B	C	D
1/2	200	4.25	5.50	5.00	2.32	7.89
	300	4.25	5.50	5.24	2.76	8.44
	500	4.25	5.50	6.10	3.27	8.55
3/4	200	4.62	6.00	5.00	2.32	8.09
	300	4.62	6.00	5.24	2.76	8.64
	500	4.62	6.00	6.10	3.27	8.75
1	300	5.00	6.50	5.24	2.76	8.91
	500	5.00	6.50	6.10	3.27	9.02
	700	5.00	6.50	6.97	3.58	9.49
1 1/2	500	6.50	7.50	6.10	3.27	10.10
	700	6.50	7.50	6.97	3.58	10.21
	1030	6.50	7.50	7.99	3.94	10.81
2	500	7.00	8.50	6.10	3.27	10.15
	700	7.00	8.50	6.97	3.58	10.26
	1030	7.00	8.50	7.99	3.94	10.86
3	700	8.00	11.12	6.97	3.58	11.01
	1400	8.00	11.12	8.50	4.72	12.51
	2200	8.00	11.12	11.18	4.72	12.77
4	1030	9.00	12.00	7.99	3.94	12.98
	2200	9.00	12.00	11.18	4.72	14.14
	2900	9.00	12.00	11.42	5.39	14.94
6	2200	11.00	N/A	11.18	4.72	16.73
	2900	11.00	N/A	11.42	5.39	17.53
	5800	11.00	N/A	14.49	6.77	19.72

Envelope Dimensional Data (mm)

Size (in.)	Actuator Model	Dimensions (mm)				
		A / 150	A / 300	B	C	D
1/2	200	108.0	139.7	127.0	58.9	200.4
	300	108.0	139.7	133.1	70.1	214.4
	500	108.0	139.7	154.9	83.1	217.2
3/4	200	117.3	152.4	127.0	58.9	205.5
	300	117.3	152.4	133.1	70.1	219.5
	500	117.3	152.4	154.9	83.1	222.3
1	300	127.0	165.1	133.1	70.1	226.3
	500	127.0	165.1	154.9	83.1	229.1
	700	127.0	165.1	177.0	90.9	241.0
1 1/2	500	165.1	190.5	154.9	83.1	256.5
	700	165.1	190.5	177.0	90.9	259.3
	1030	165.1	190.5	202.9	100.1	274.6
2	500	177.8	215.9	154.9	83.1	257.8
	700	177.8	215.9	177.0	90.9	260.6
	1030	177.8	215.9	202.9	100.1	275.8
3	700	203.2	282.4	177.0	90.9	279.7
	1400	203.2	282.4	215.9	119.9	317.8
	2200	203.2	282.4	284.0	119.9	324.4
4	1030	228.6	304.8	202.9	100.1	329.7
	2200	228.6	304.8	284.0	119.9	359.2
	2900	228.6	304.8	290.1	135.1	379.5
6	2200	279.4	N/A	284.0	119.9	424.9
	2900	279.4	N/A	290.1	135.1	445.3
	5800	279.4	N/A	368.0	172.0	500.9

Contromatics Series PF Actuator Sizing

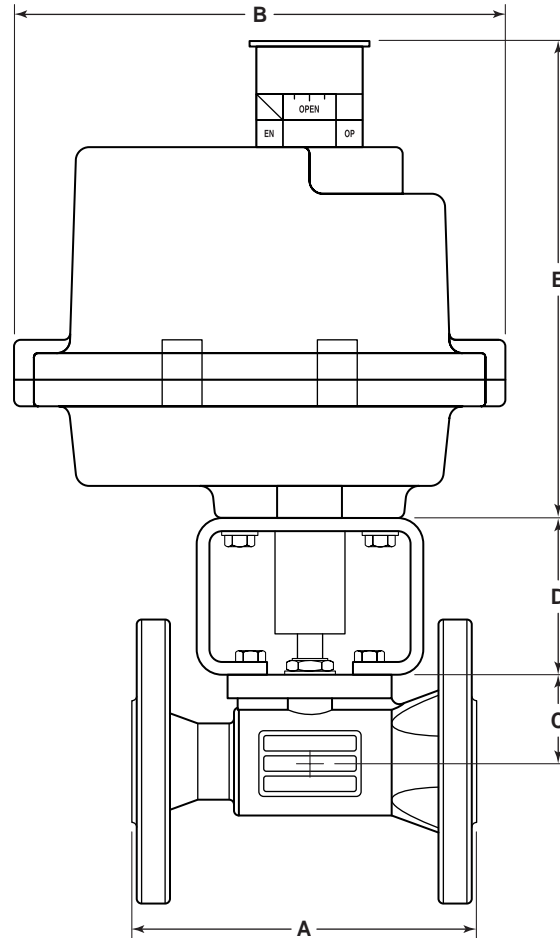

Envelope Dimensional Data (in.)

Size (in.)	Actuator Model	Dimensions (in.)				
		A	B	C	D	E
1/2	400	4.25	9.25	1.07	3.00	9.38
3/4	400	4.62	9.25	1.27	3.00	9.38
1	400	5.00	9.25	1.54	3.00	9.38
1 1/2	400	6.50	9.25	2.26	3.00	9.38
2	400	7.00	9.25	2.31	3.00	9.38
3	700	8.00	9.25	3.06	3.00	9.38
4	1000	9.00	9.25	4.43	3.75	9.38
6	2000	10.50	9.25	6.02	4.00	11.60

Envelope Dimensional Data (mm)

Size (in.)	Actuator Model	Dimensions (mm)				
		A	B	C	D	E
1/2	400	108.0	235.0	27.2	76.2	238.3
3/4	400	117.3	235.0	32.3	76.2	238.3
1	400	127.0	235.0	39.1	76.2	238.3
1 1/2	400	165.1	235.0	57.4	76.2	238.3
2	400	177.8	235.0	58.7	76.2	238.3
3	700	203.2	235.0	77.7	76.2	238.3
4	1000	228.6	235.0	112.5	95.3	238.3
6	2000	266.7	235.0	152.9	101.6	294.6

Engineering Data

Seat Rating, 1/2" - 2"

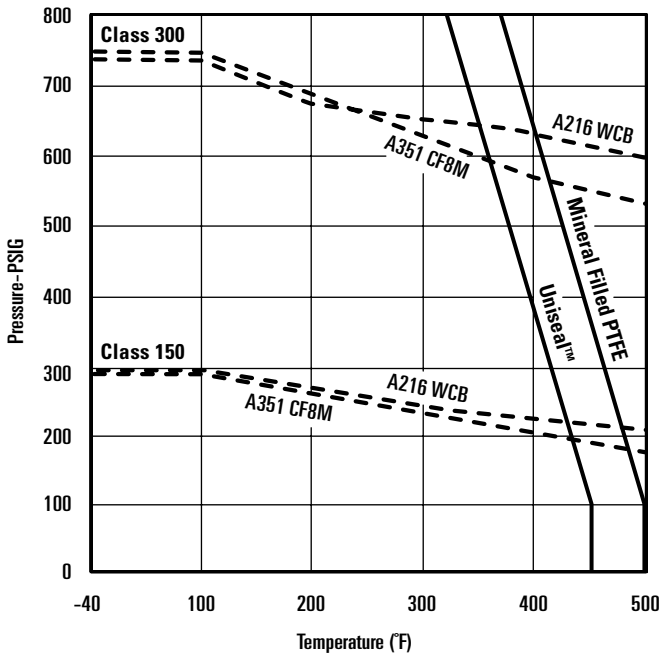

Seat Rating, 2 1/2" - 10"

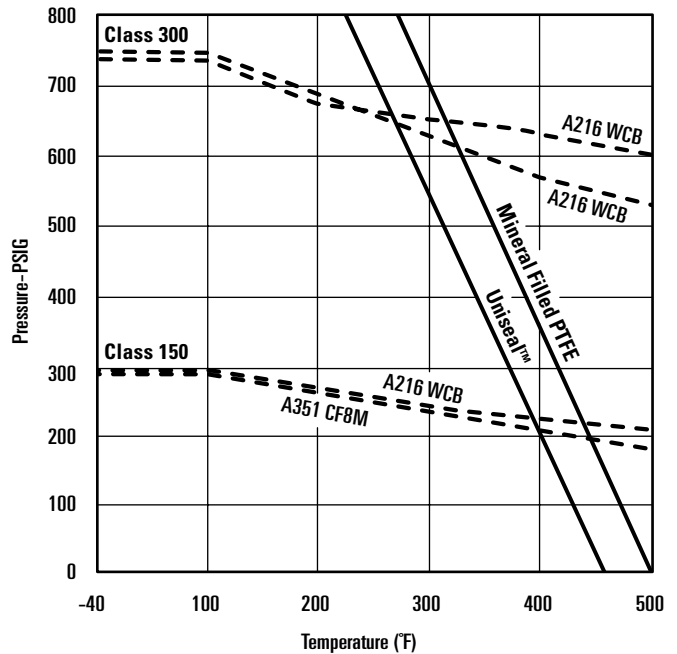

Temperature Rating

Seat Material	°F	°C
Uniseal™	450°	232°
Min. Filled PTFE	500°	260°
PEEK™	600°	316°

Pressure Range

Pressure Range @ 100°F		
Body Material	Cl. 150	Cl. 300
CS, WCB	285	740
SS, CF8M	275	720

Flow Coefficient (C_v)

Size (in.)	Cl. 150	Cl. 300
1 FP	98	98
1 1/2 FP	265	265
2 RP	140	140
2 FP	470	420
3 RP	220	210
3 FP	1240	1050
4 RP	630	600
4 FP	2770	2000

Size (In.)	Cl. 150	Cl. 300
6 RP	925	910
6 FP	5249	5100
8 RP	2500	2400
8 FP	10,750	10,300
10 RP	5000	4825
10 FP	17,775	—
12 RP	8400	—

Steam Rating (Saturated)

Seat Material	Rating
Min. Filled PTFE	250 WSP
Uniseal™	150 WSP

Vacuum Rating

10 Microns Hg

Low Temperature Limits

Body Material	°F	°C
CS, WCB	-20°	-28.9°
SS, CF8M	-50°	-45.6°

Seat Material	°F	°C
Uniseal™	-50°	-45.6°
Min. Filled PTFE	-50°	-45.6°
PEEK™	-50°	-45.6°

Seat Material	°F	°C
TFE/GRF Packing	-50°	-45.6°

Method of Calculating Flow

The Flow Coefficient "C_v" of a valve is the flow rate of water (gallons/minute) through a fully opened valve, with a pressure drop of 1 psi across the valve. To find the flow of liquid through valve from the C_v, use the following formulas:

Liquid Flow

QL = flow rate of liquid (gal./min.)

ΔP = differential pressure across the valve (psi)

G = specific gravity of liquid (for water, G=1)

$$Q_L = C_v \sqrt{\frac{\Delta P}{G}}$$

Gas Flow

Qg = flow rate of gas (CFH at STP)

P2 = outlet pressure (psia)

g = Specific gravity of gas (for air, g=1.000)

$$Q_g = 61 C_v \sqrt{\frac{P_2 \Delta P}{g}}$$

For non-critical flow
 $\left\{ \frac{\Delta P}{P_2} < 1.0 \right\}$

Worldwide Sales Offices



**Contromatics, a leading brand of CIRCOR Energy Products, Inc.
reaches into every corner of the globe serving the oil & gas and industrial marketplace.**

**Supplying an extensive range of product offerings
through a worldwide network of manufacturer representatives and distributors,
Contromatics is the right choice for all your flow control needs.**

World Headquarters

KF Valves
1500 S.E. 89th Street
Oklahoma City, OK 73149 USA
Phone: (405) 631-1533
Fax: (405) 631-5034
E-mail: sales@circorenergy.com
www.circorenergy.com

US Industrial

Contromatics
1500 S.E. 89th Street
Oklahoma City, OK 73149 USA
Phone: (405) 631-1533
Fax: (405) 631-5034
E-mail: sales@circorenergy.com
www.circorenergy.com

Canada

KF Valves
9430-39th Avenue, Edmonton
Alberta, Canada T6E 5T9
Phone: (780) 463-8633
Fax: (780) 461-1588
E-mail: kfinfo@circorenergy.com
www.circorenergy.com



Licensed for Manufacture
in accordance with API 6A
& 6D and Firetest
to API 6FA and 607



Registered to the ISO 9001
Quality System Standard,
accredited by U.K., Dutch
and German qualifying
authorities.



www.circorenergy.com

Contro-Flanged BLV-May-08-HP • ©2008 CIRCOR Energy Products, Inc. • Contromatics is a CIRCOR Energy Products Brand • Litho USA • Contromatics reserves the right to change designs, materials or specifications without notice or without obligation to furnish or install such changes on products previously or subsequently sold. • PEEK™ is a trademark of Victrex Plc. • Monel® is a registered trademark of Special Metals Corporation, USA.